

LAURA ASHLEY

SINCE 1953

CLIFTON Bed

Thank you for purchasing this product. Please read the instructions carefully before use to ensure safe and satisfactory operation of this product.

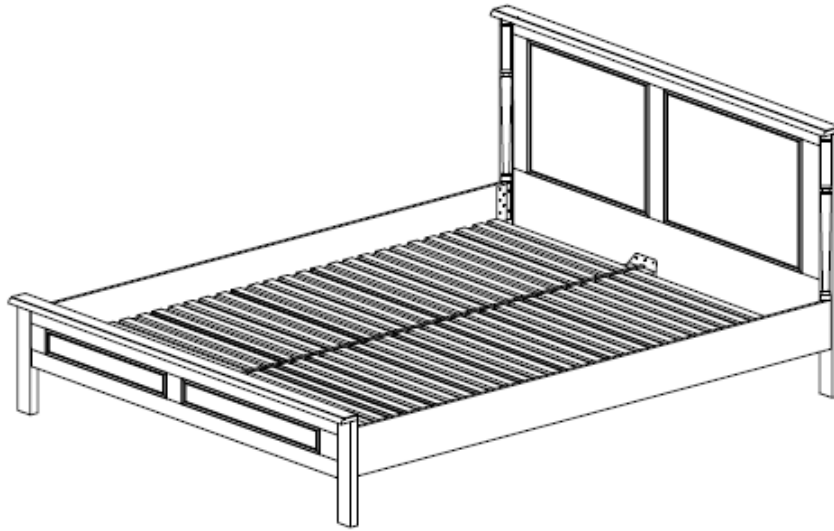

Necessary Tools:



Allen Key (included)







Please check the pack contents before you begin. A full checklist of components is given in this leaflet. If any components are missing, please contact the retailer from whom you bought this product.

Safety Advice and Assembly Recommendations

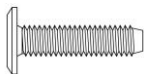
- Do not stand or lean on this product.
- Make sure the area is clear when unpacking and positioning this product.
- This product is heavy; it should be assembled as near as possible to the point of use. Take care when lifting to avoid personal injury and /or damage to the product.
- Keep small children/pets away from the assembly area. This product has small component parts that are a choking hazard.
- Make sure you assemble this product correctly as per the instructions, and ensure all fittings are tight.
- A minimum of two people is required to lift the bed into its position.
- We recommend that the packaging is used to protect the surfaces during assembly.

Fittings and parts checklist

A	Bolt M8X30 x 12		D	Allen Key x 1	
B	Screw Ø 3.5 x25 x 12				
C	Dowel D8X25 x 8				

Step by step assembly instructions

A minimum of two people is required to assemble this product.

Step One

- Attach one side rail to the headboard. Use bolts No. A. Allen key provided.

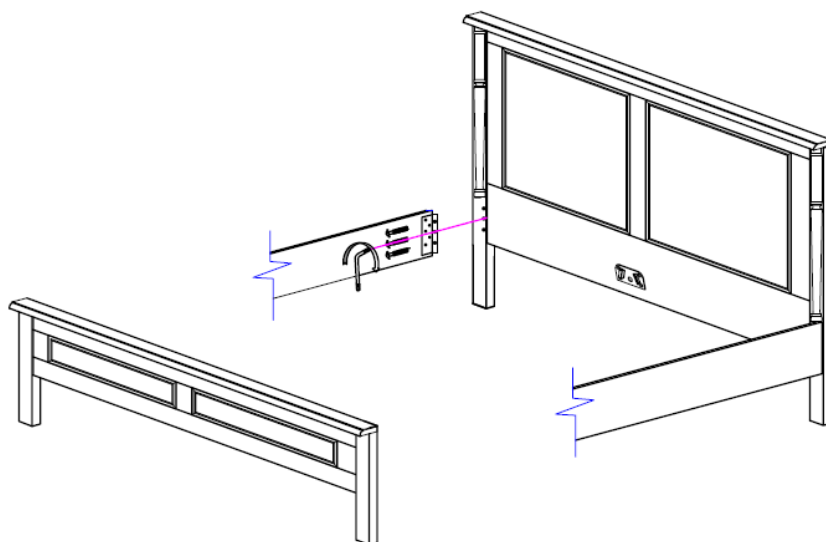

Step Two

- Repeat Step One with the other side rail.

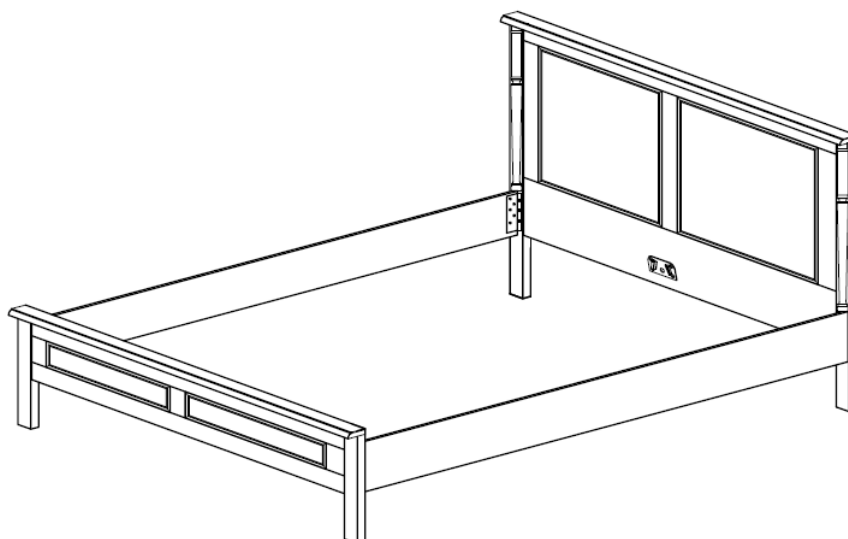

Step Three

- Attach 2 of the adjustable support legs to the centre rail. Attach by screwing clockwise.

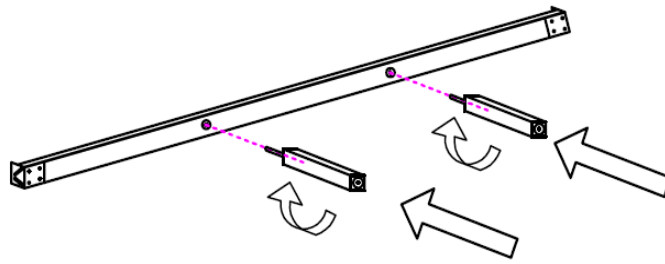

Step Four

- Place the centre rail into position by pressing the metal brackets onto each other.

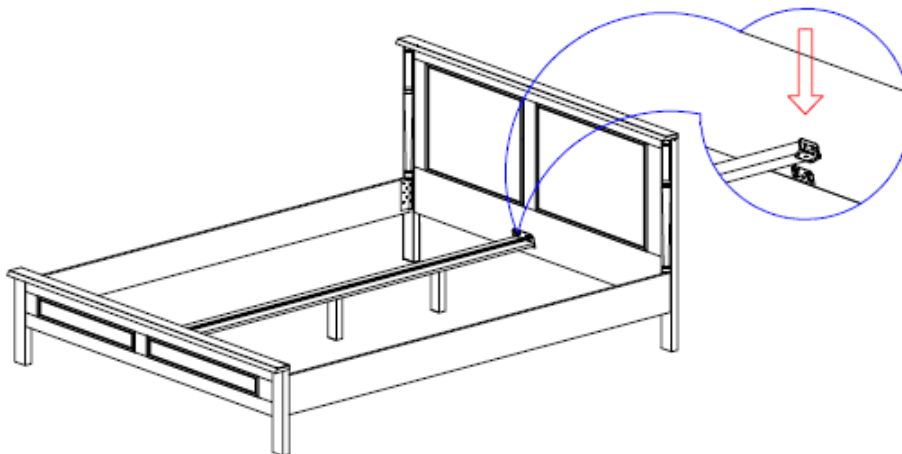

Step Five

- Place 8 x wood dowels No.C into the pre-drilled positions on the side rails.
- Place the slats between the side rails and the centre rail.
- Align the holes in the slats with the holes in the rails. Secure with 12 screws No.B, tighten well.

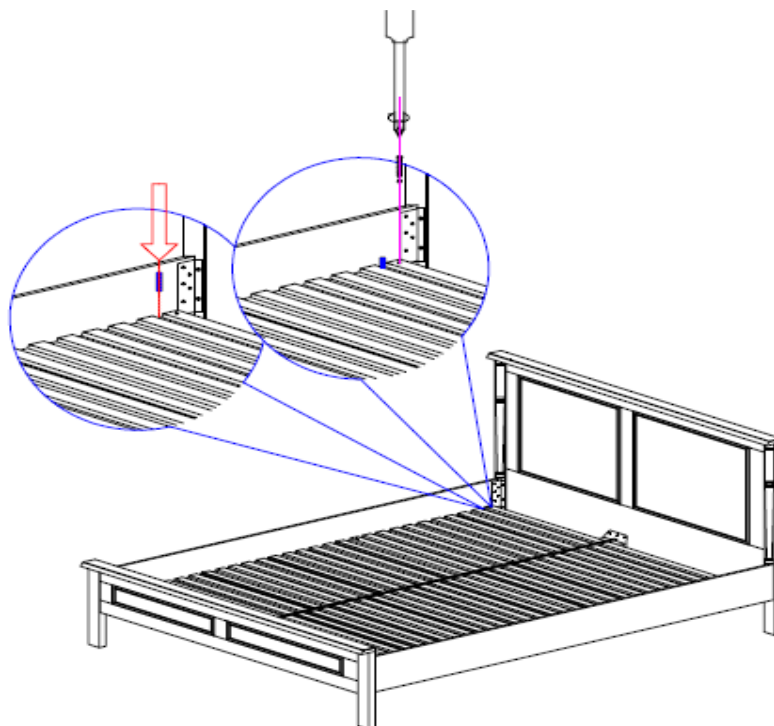

Step Six

- To compensate for uneven floors, adjust the middle support legs, as necessary. Leave a small gap between a foot and a floor. The foot should only touch the floor when sleeping in a bed.

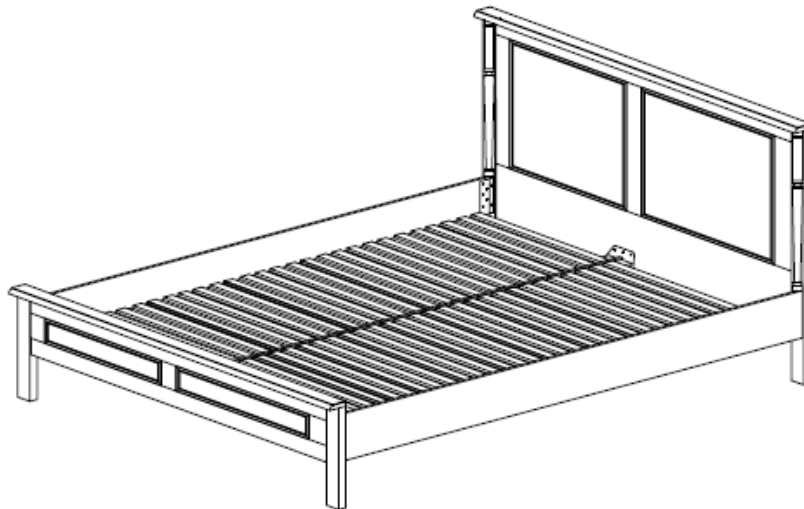

Care and Maintenance: please refer to Laura Ashley Care Guide.

PLEASE KEEP THESE INSTRUCTIONS FOR FUTURE REFERENCE