

MADE⁺

PAVIA

Bedside Table

Table de chevet

Nachtkastje

Nachttisch

Mesilla de noche



GB - Recommendations for the continual safe use of this product are stated on the final page of these instructions. Please retain for future reference.

FR - Les conseils d'utilisation de ce produit sont indiqués sur la dernière page de ces instructions. Veuillez les conserver pour vous y référer si besoin.

NL - Aanwijzingen voor veilig gebruik van dit meubel worden toegelicht op de laatste pagina van deze Instructies. Bewaar deze folder goed.

DE - Auf der letzten Seite dieser Anleitung findest du Hinweise für eine langfristig sichere Anwendung dieses Produktes. Bitte bewahre sie gut auf.

ES - Las recomendaciones para el uso continuado de este producto figuran en la última página de estas instrucciones. Por favor, consérvalas para futuras consultas.

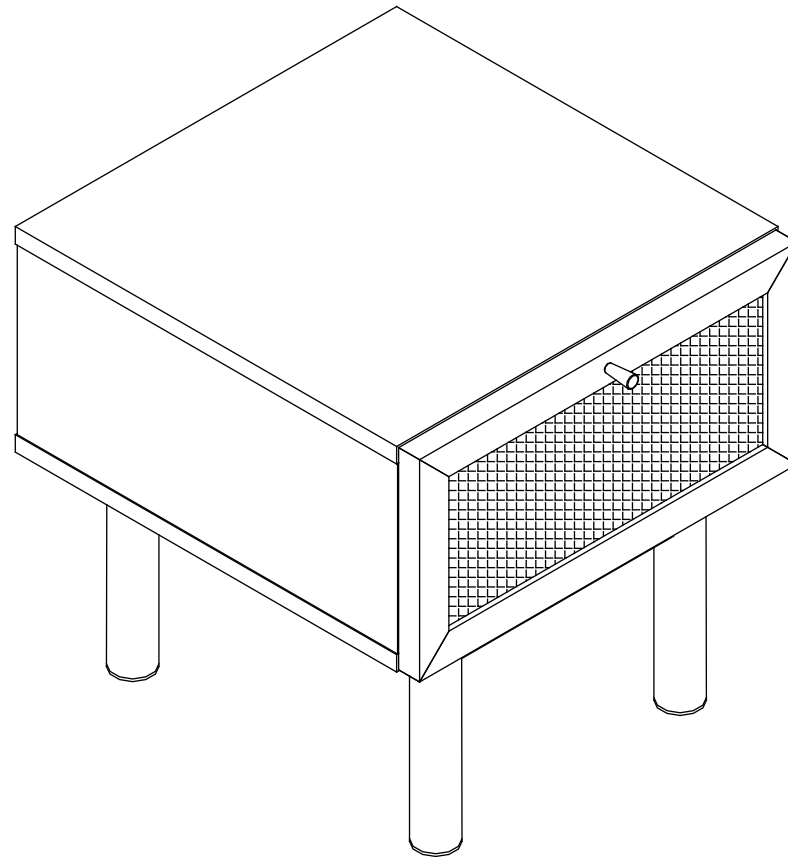

PAVIA BEDSIDE TABLE - 407779/B17448
Made In China



SAFETY DISCLAIMER

GB

- A safety strap / bracket is included with this item.

Please ensure the strap / bracket is attached to the product and the wall to ensure it remains stable at all times during use.

- The unit must only be used on a level floor.

FR

- Une sangle / un support de sécurité est inclus dans cet article.

Assurez-vous que la sangle / le support soit fixé au produit et au mur pour s'assurer qu'il reste stable en permanence pendant l'utilisation.

- Le produit doit être utilisé à hauteur de plancher.

NL

- Dit product is inclusief veiligheids riempje / haakje.

Zorg ervoor dat het riempje / haakje aan het product en de muur bevestigd wordt zodat het stabiel blijft bij gebruik.

- Dit meubel dient alleen op een even vloer gebruikt te worden.

DE

- Dieses Produkt enthält einen Sicherheitsriemen mit Schlaufe.

Der Riemen und die Schlaufe müssen am Produkt und der Wand befestigt werden, damit das Produkt immer stabil steht.

- Stellen Sie das Produkt nur auf einem ebenen Untergrund auf.

ES

- Incluye una cinta / soporte de seguridad.

Asegúrate de que la cinta / soporte esté adherida al producto y a la pared para garantizar que permanezca estable en todo momento durante su uso.





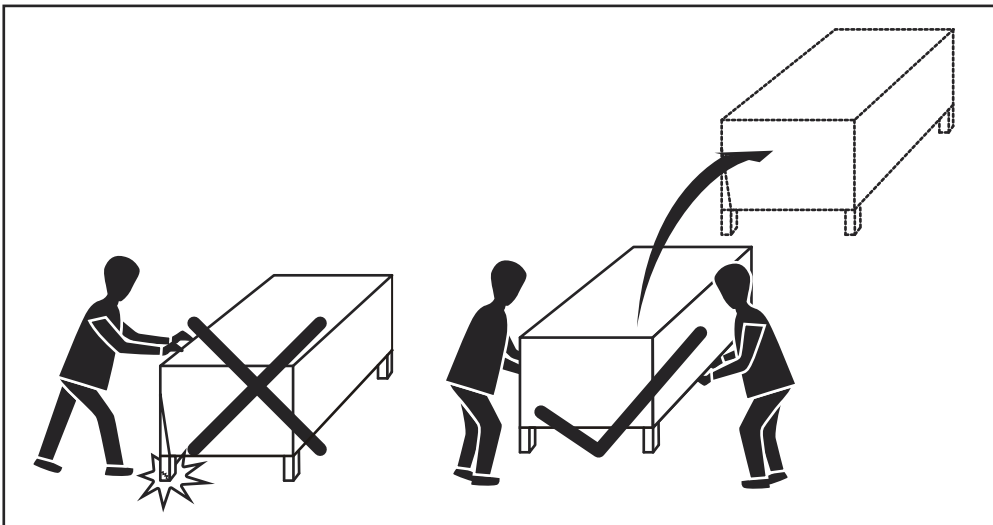
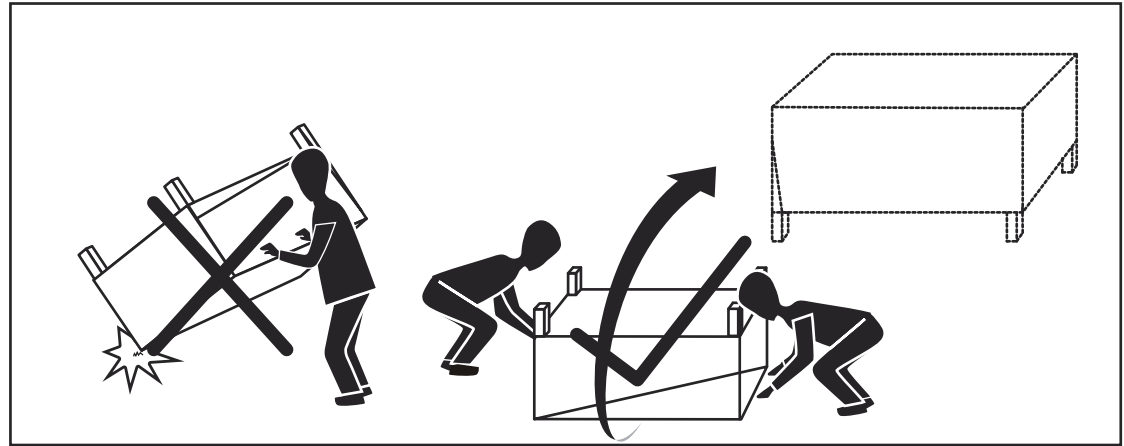
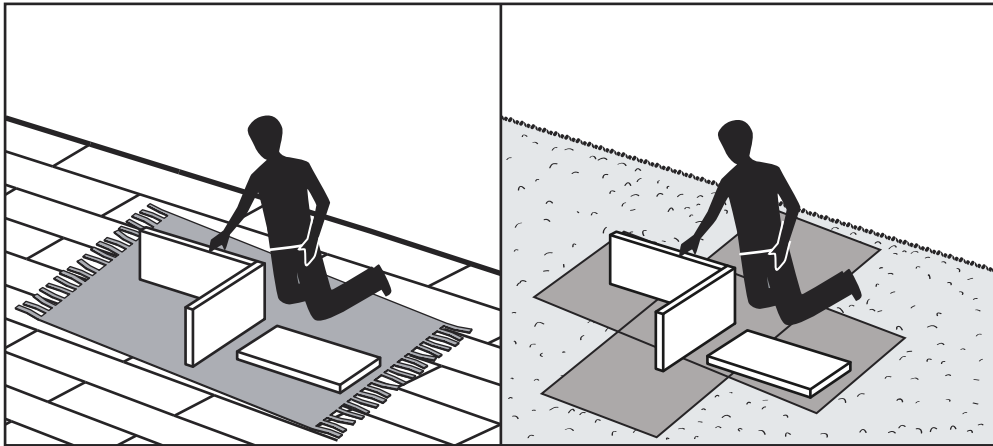
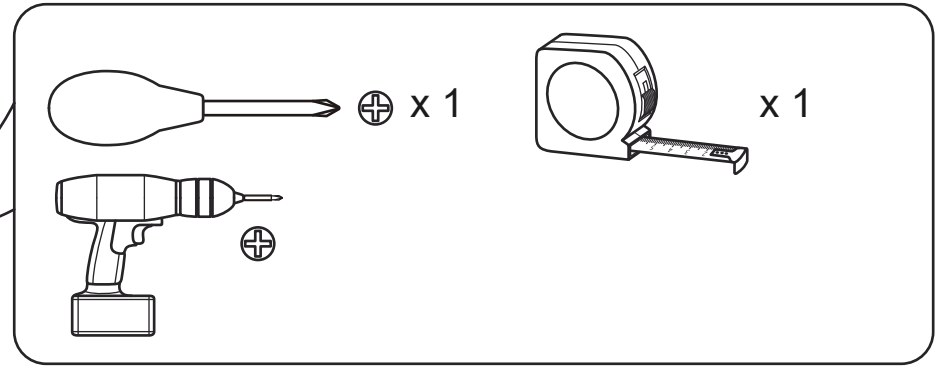
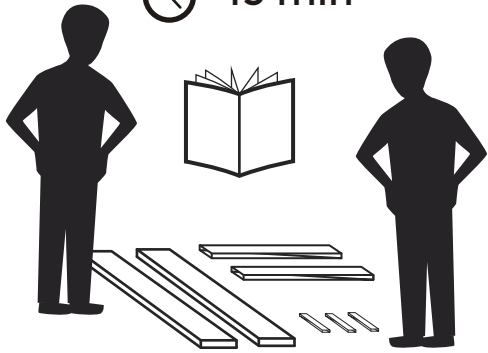

- El producto solo debe usarse en un suelo nivelado.

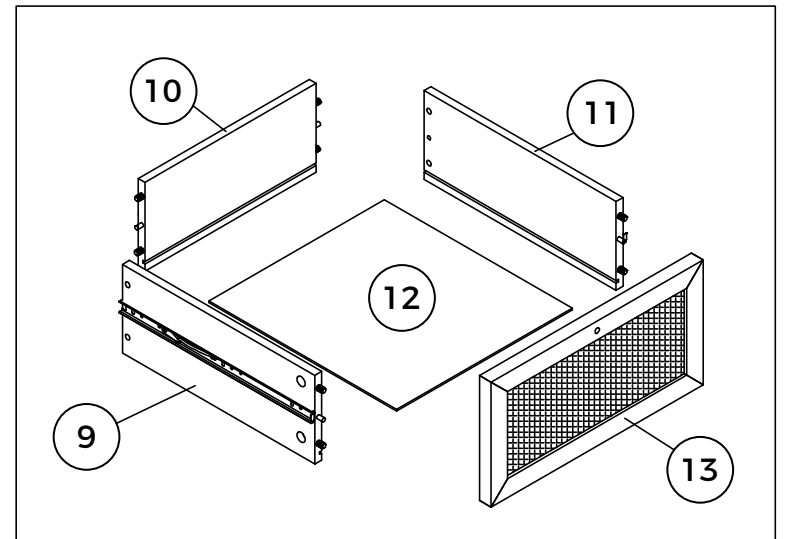
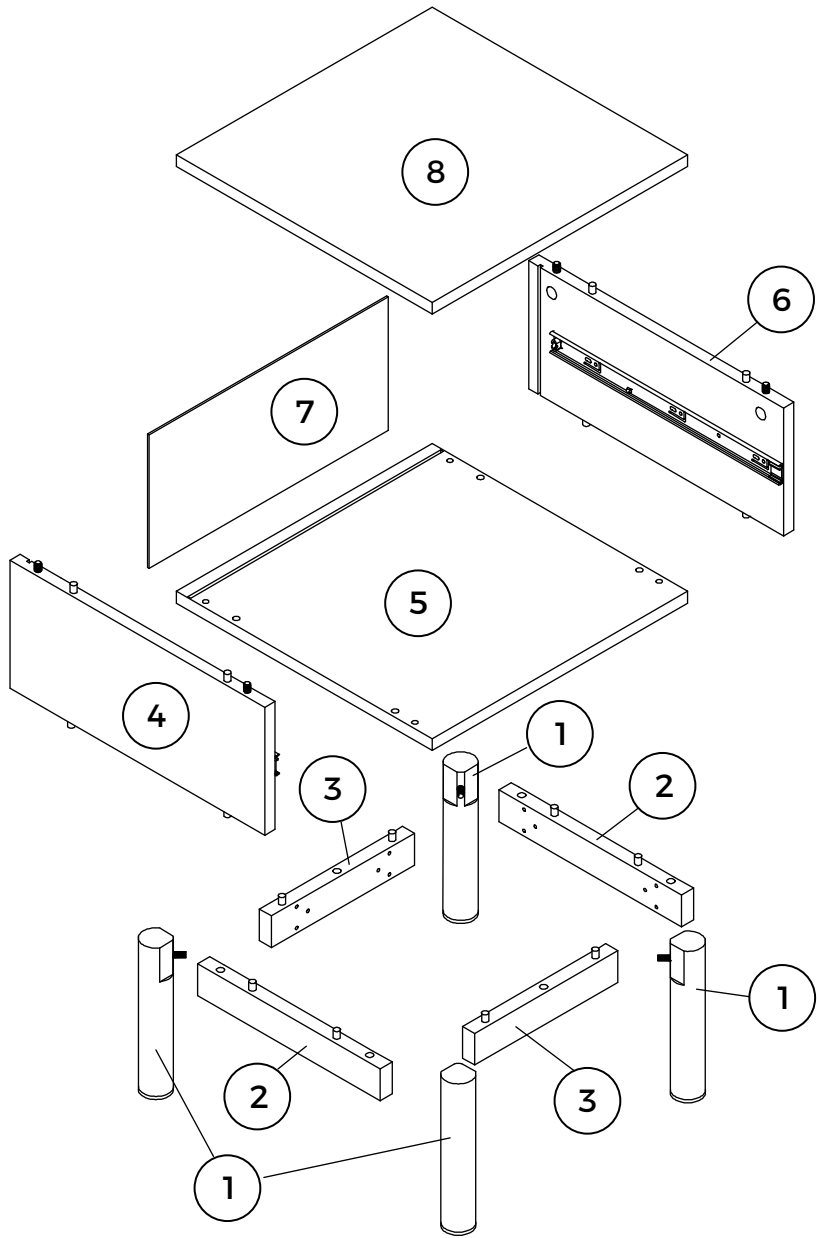
⌚ 45 min

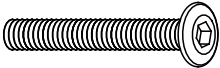
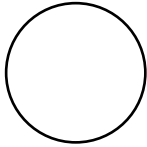

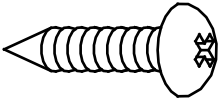
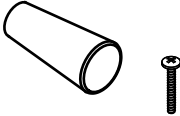
Nr	Box 1/1
1	4
2	2
3	2
4	1
5	1
6	1
7	1
8	1
9	1
10	1
11	1
12	1
13	1

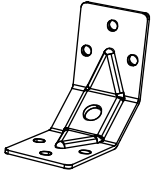
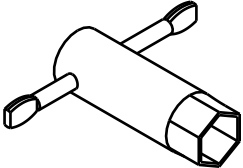
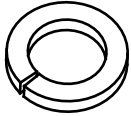

<p>B23</p>  <p>X4</p>	<p>Y35</p>  <p>X6</p>	<p>O1</p>  <p>X4</p>	<p>Y8</p>  <p>X4</p>
<p>S41</p>  <p>X24</p>	<p>E58</p>  <p>X1</p>	<p>T4</p>  <p>X1</p>	<p>T38</p>  <p>X4</p>
<p>M34</p>  <p>X4</p>	<p>T52</p>  <p>X1</p>	<p>Q3</p>  <p>X4</p>	<p>T39</p>  <p>X1</p>

1

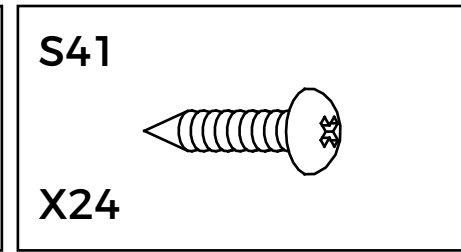
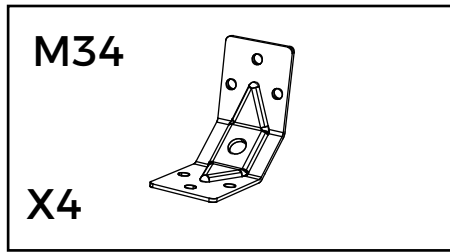
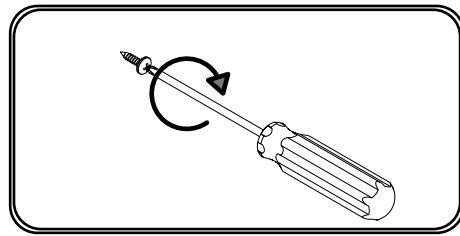

Please do not tighten all screws.

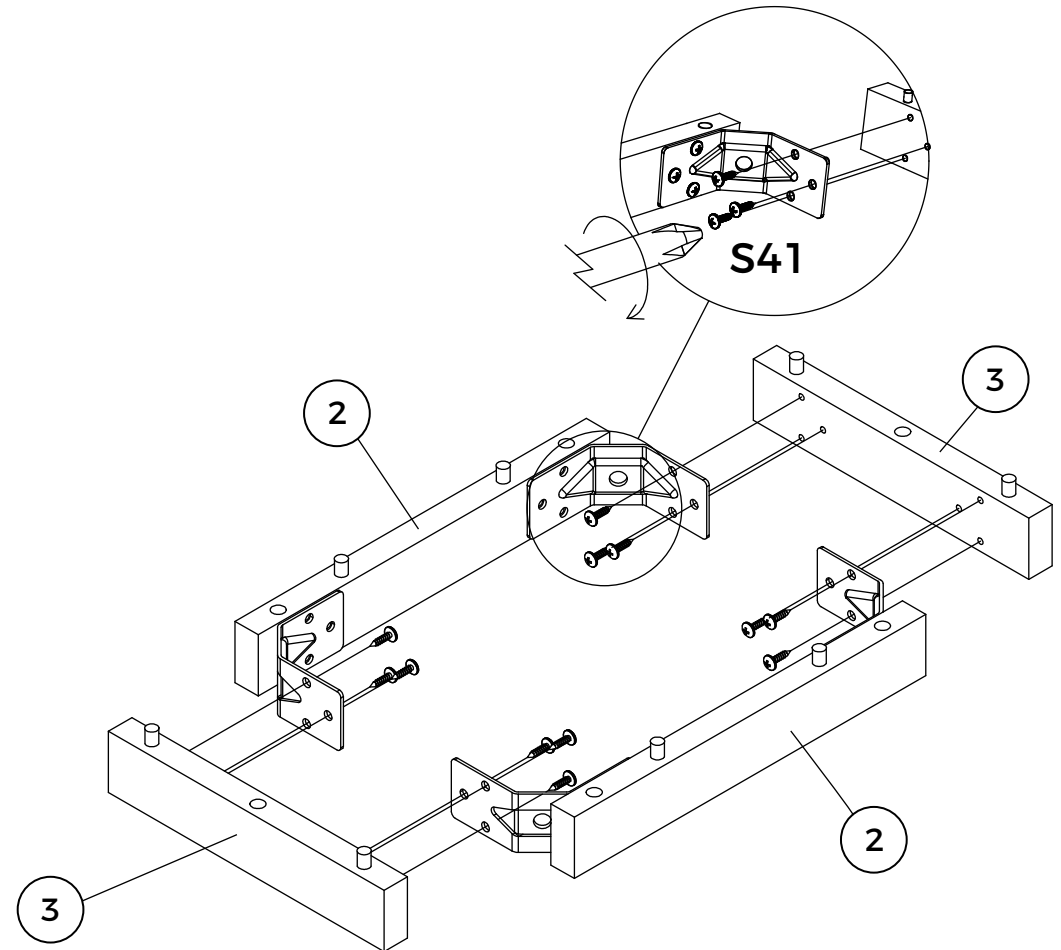
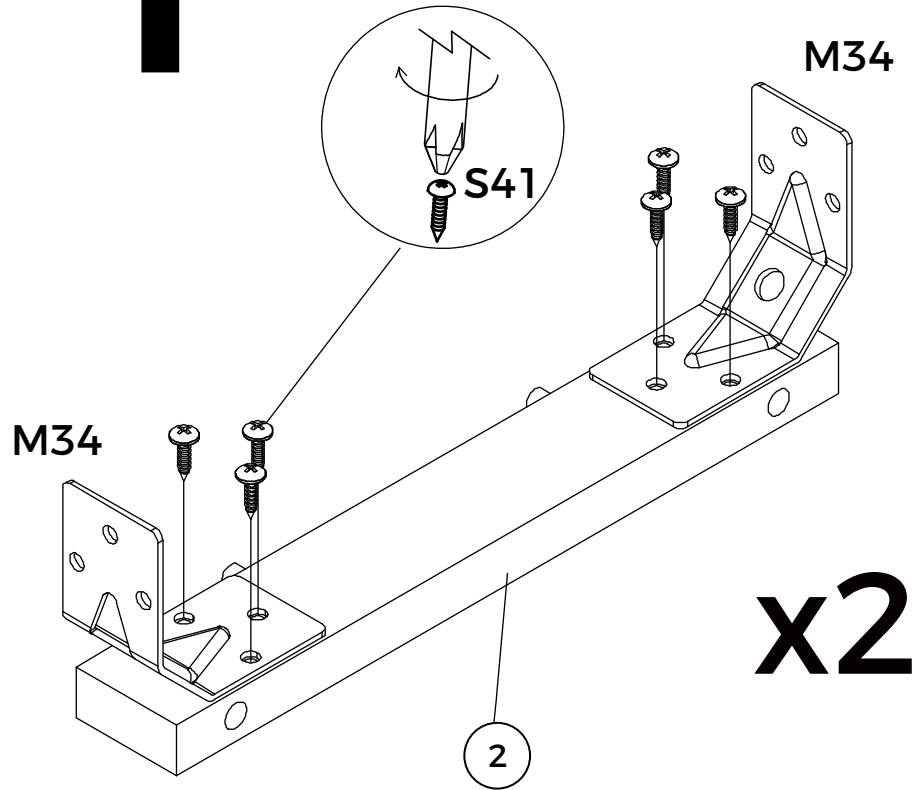

2

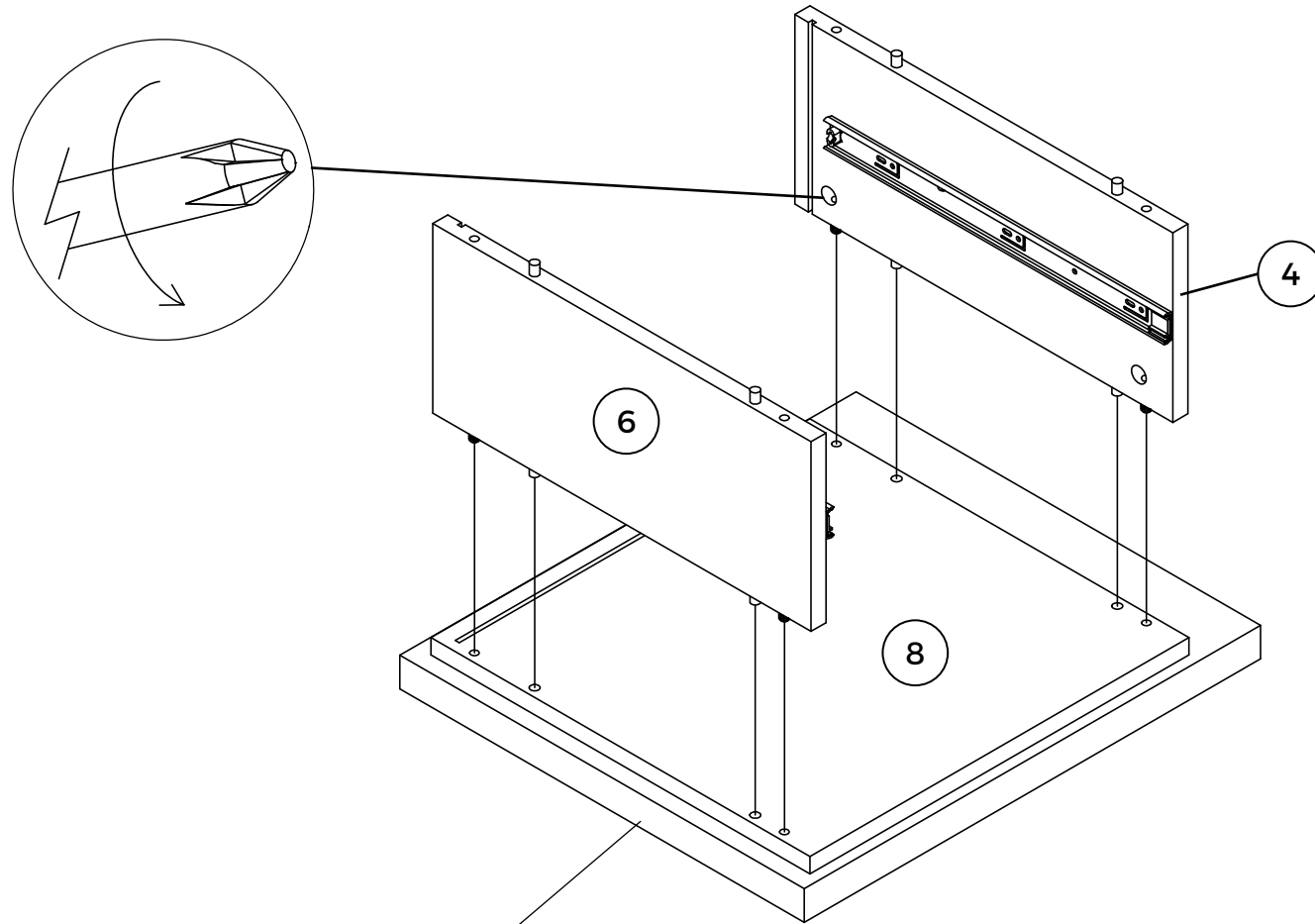
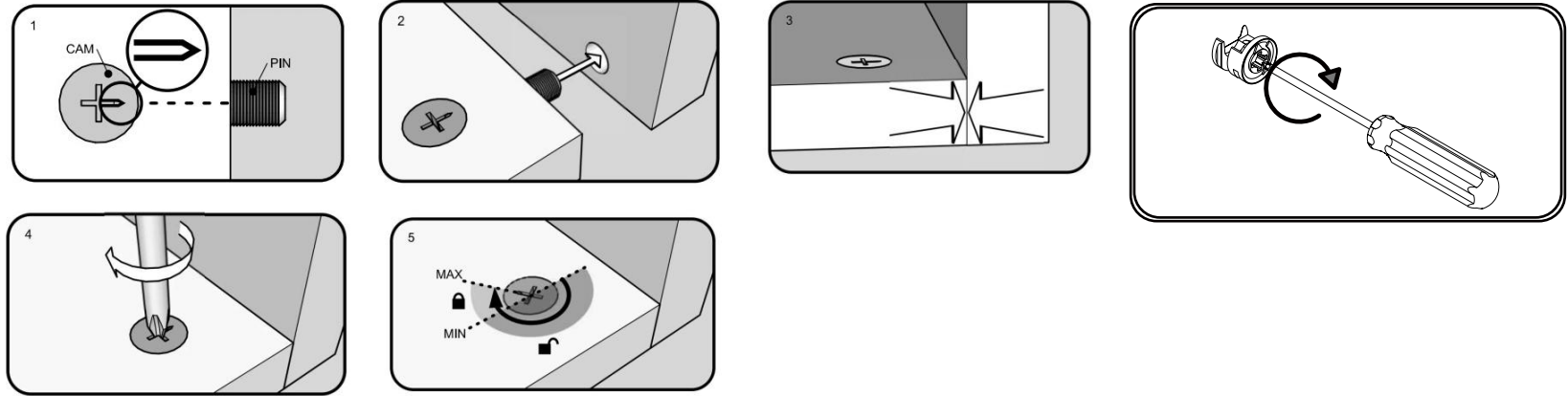

Packing Materials

3

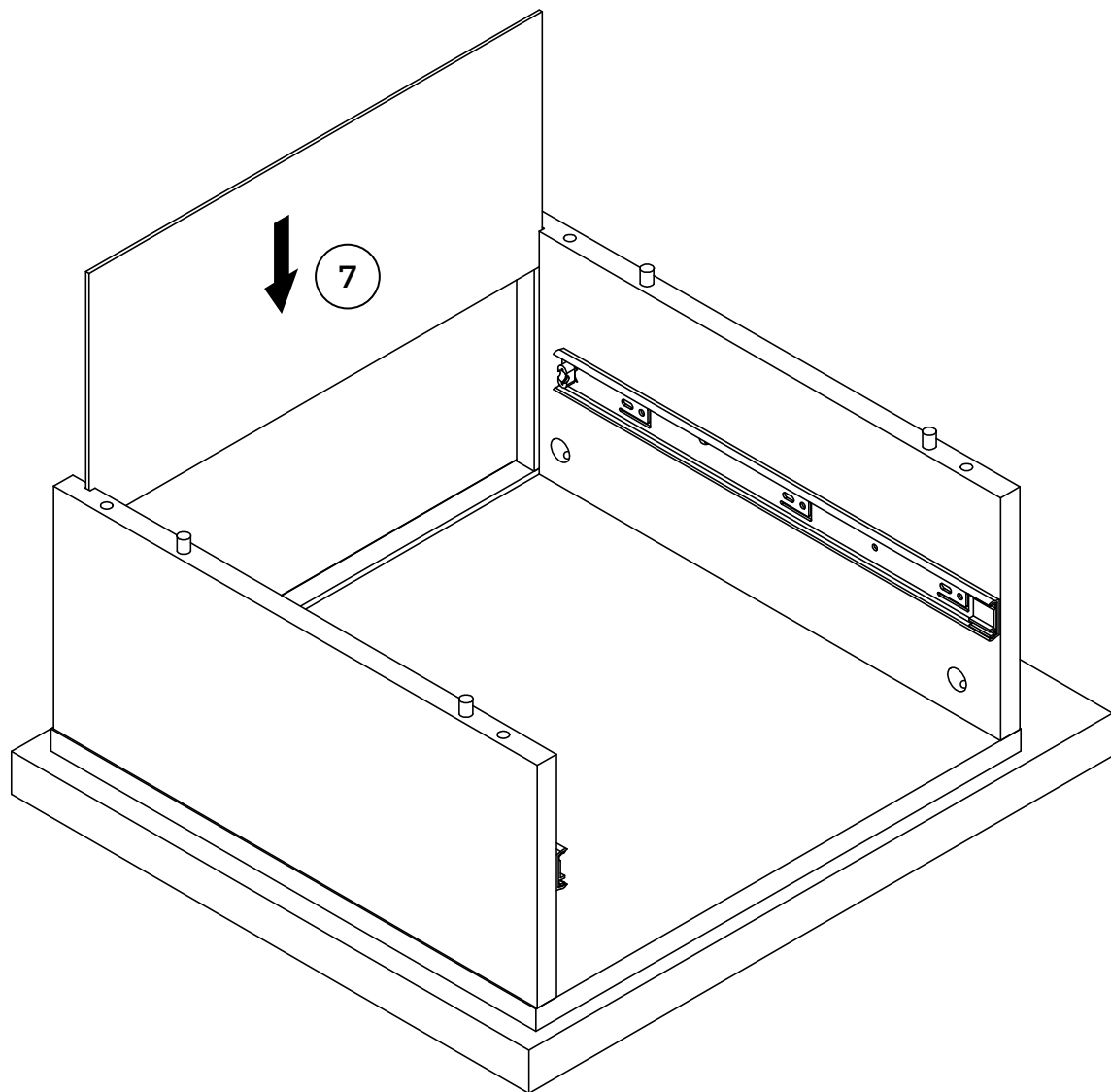

4

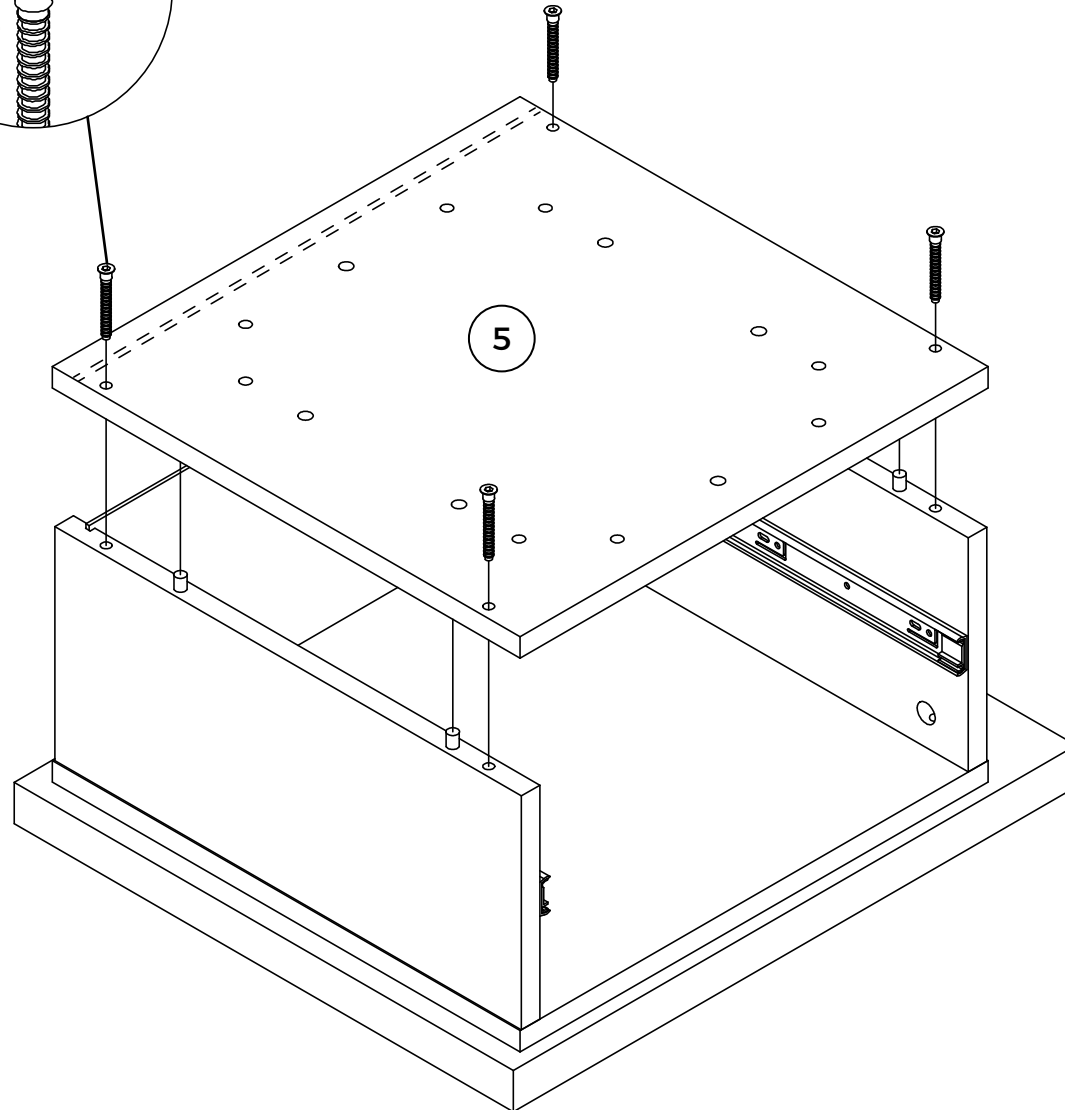
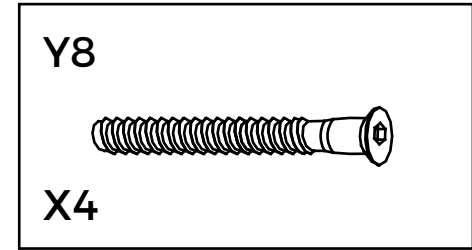
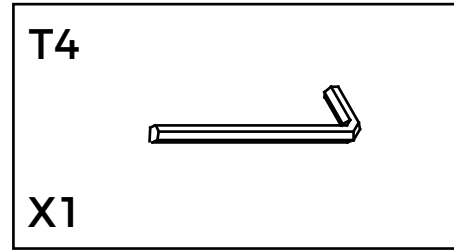
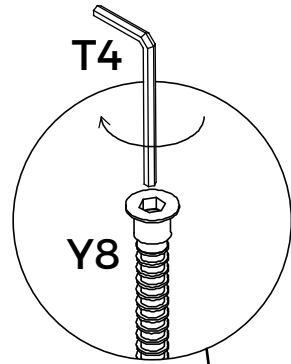

5

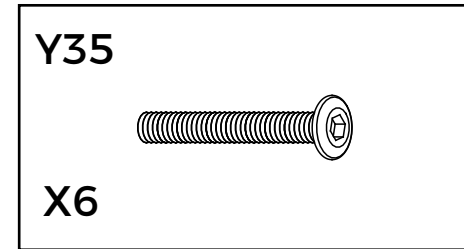
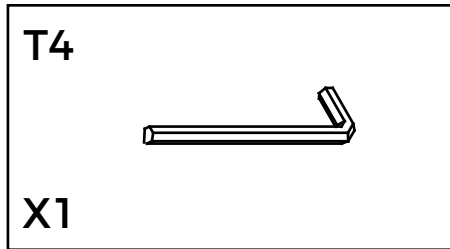

Please tighten all screws.

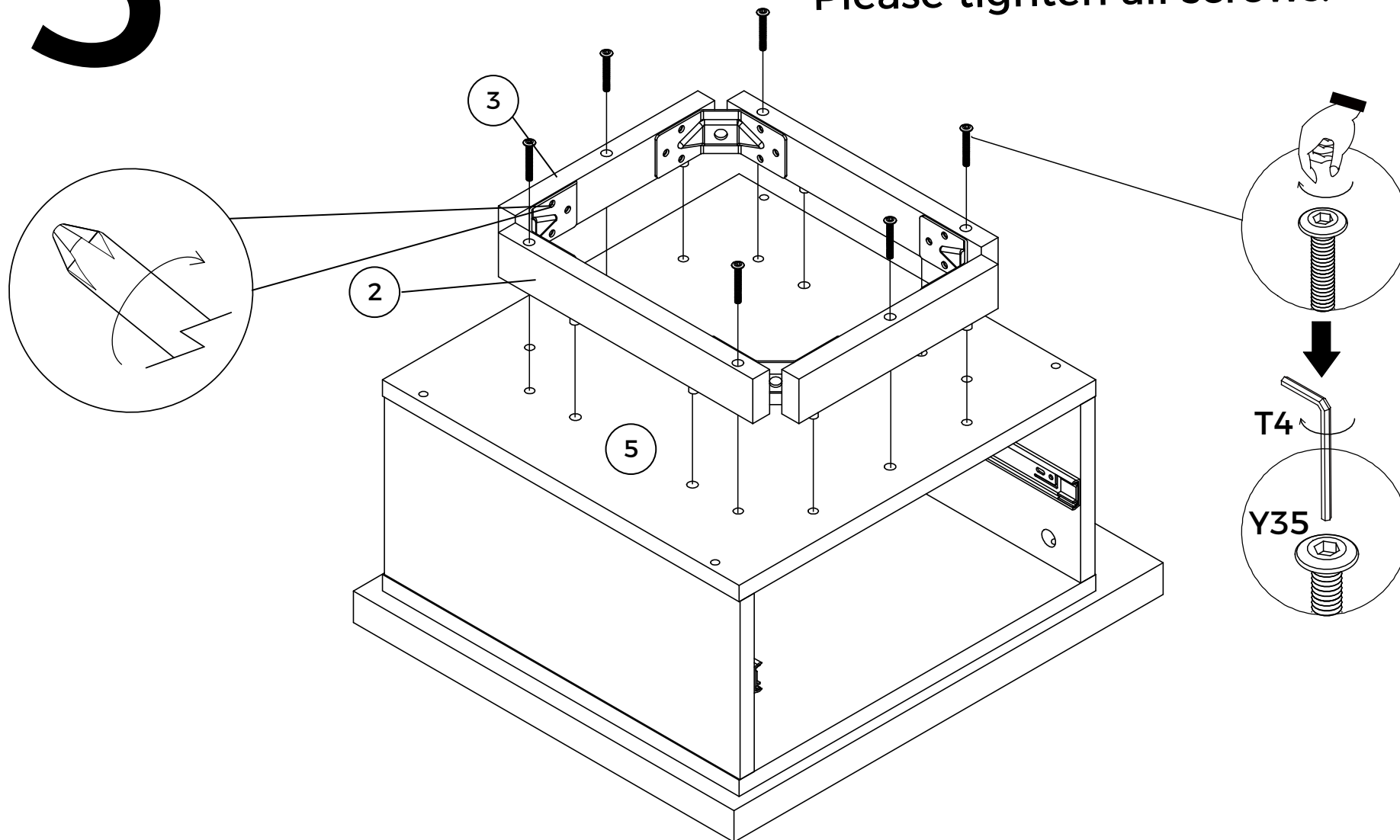

6

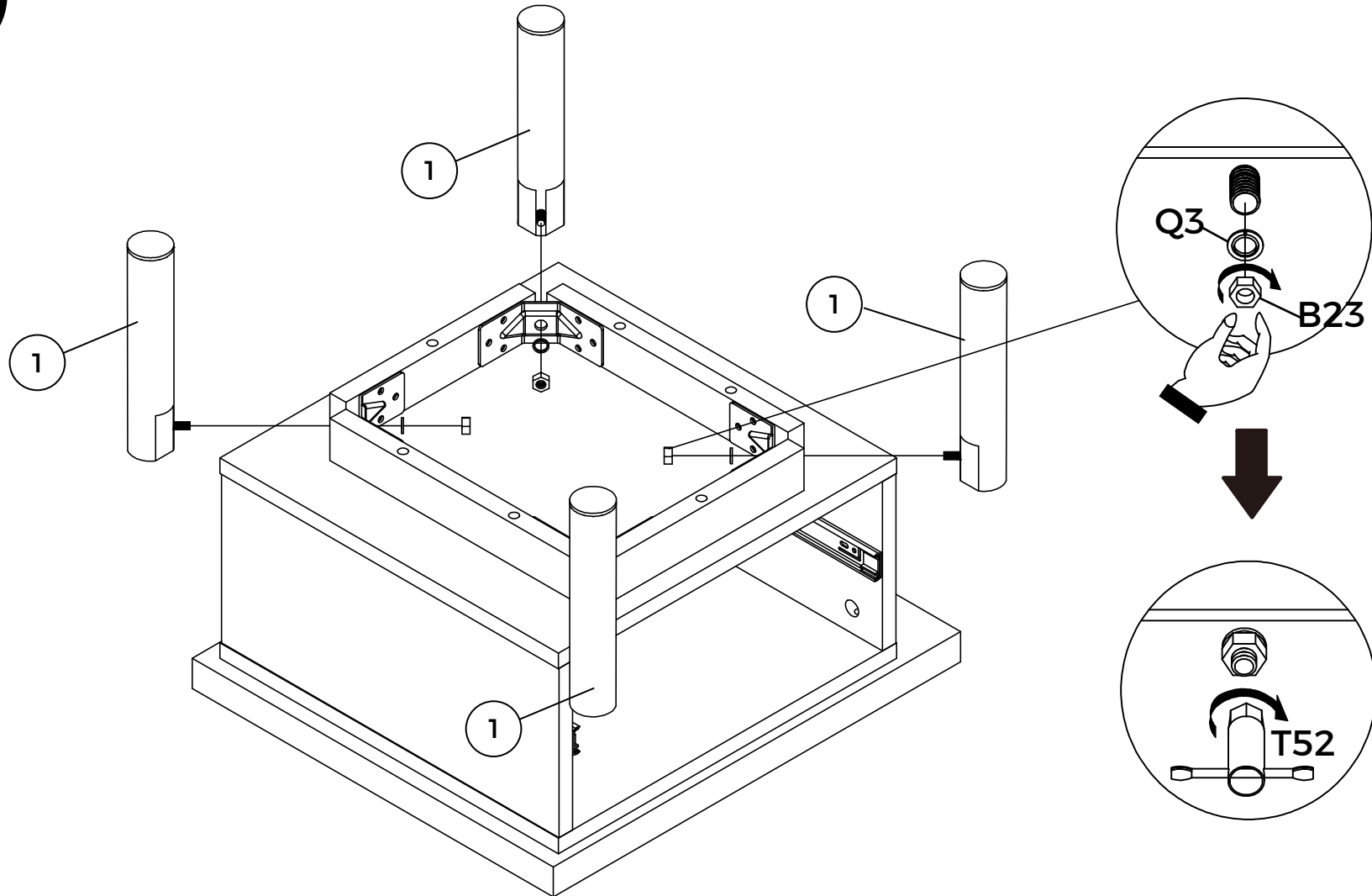
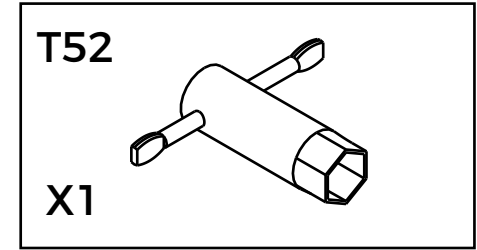
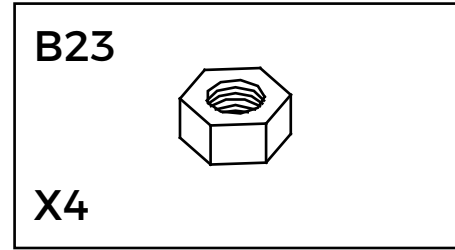
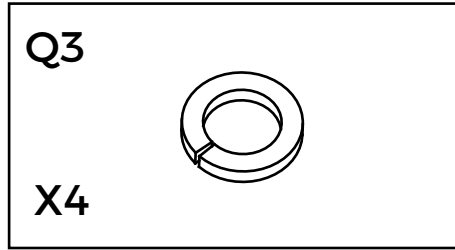

7

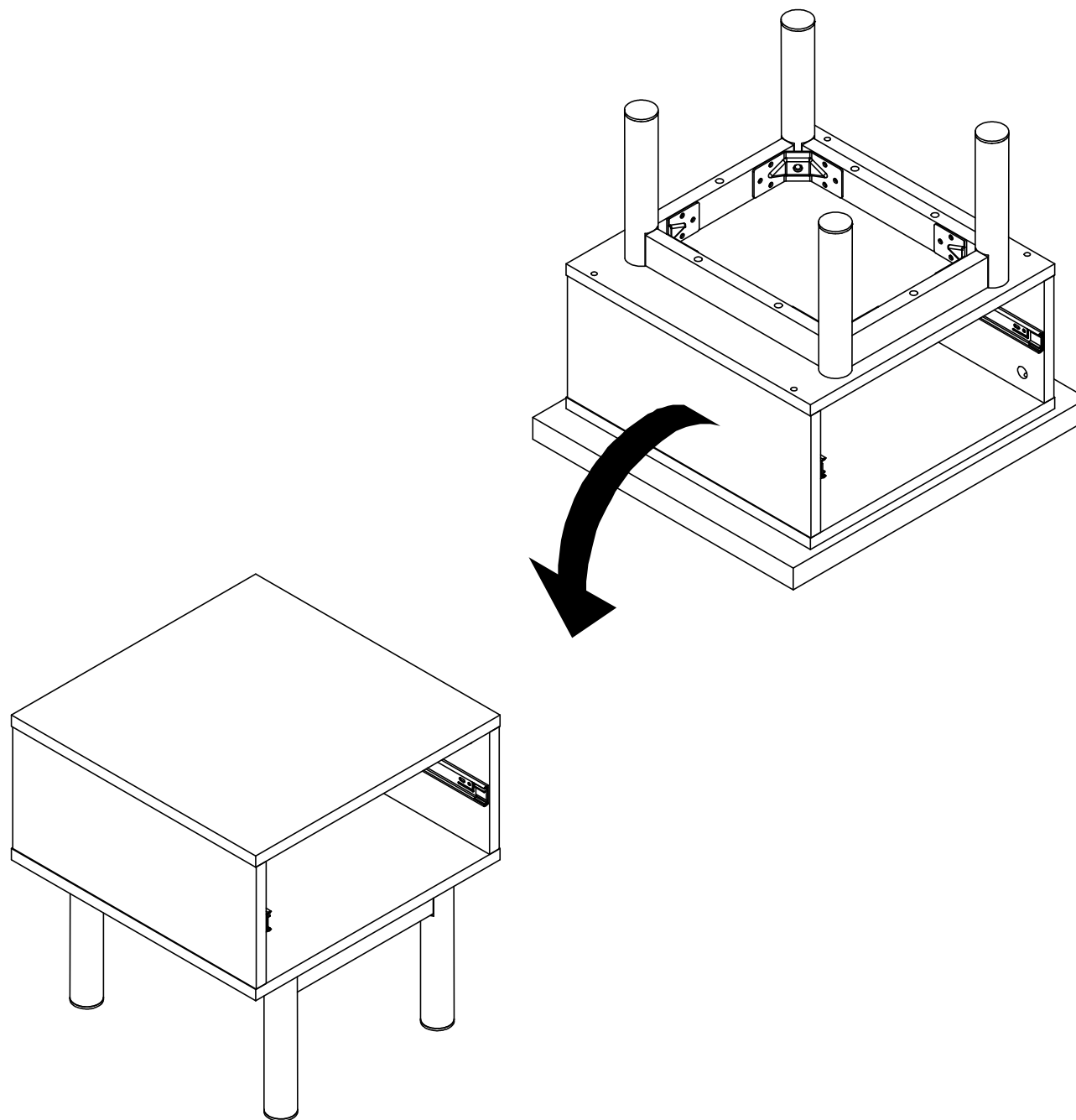

8

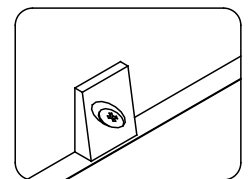
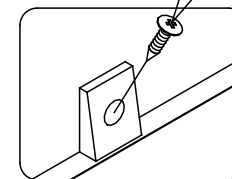
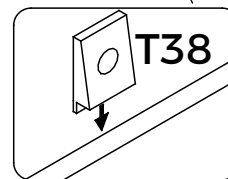
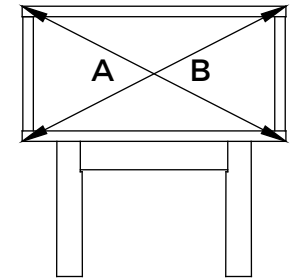
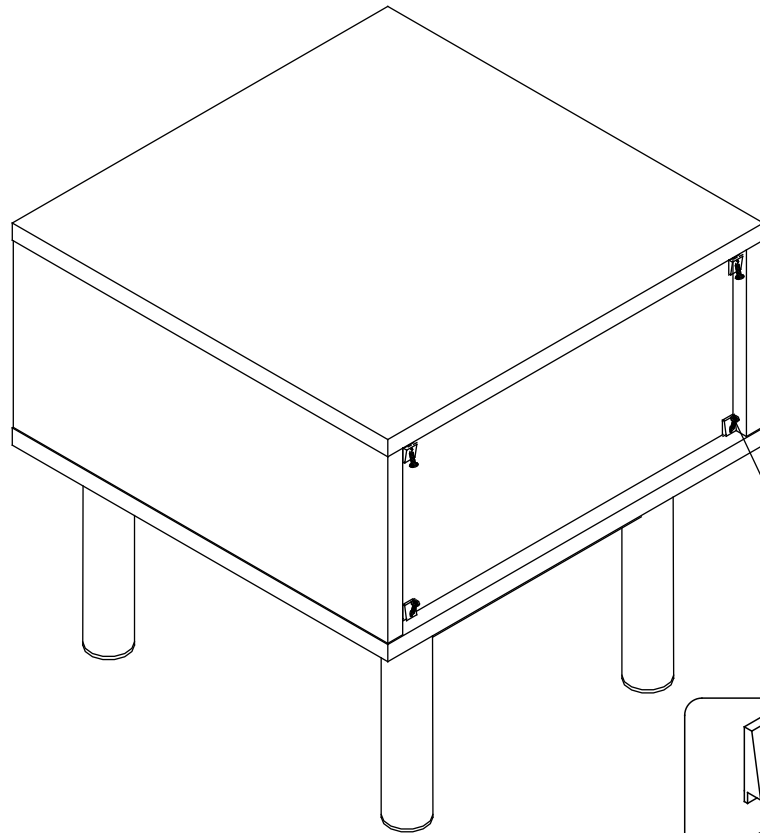
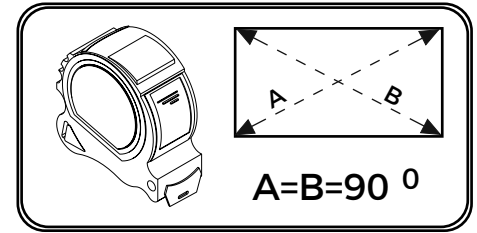
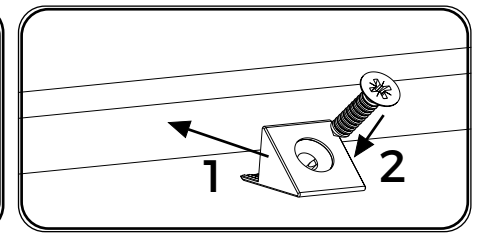
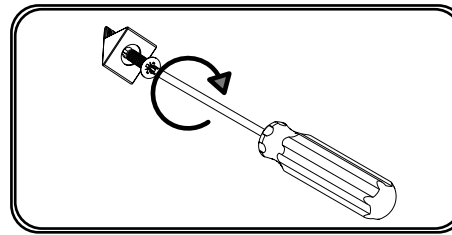
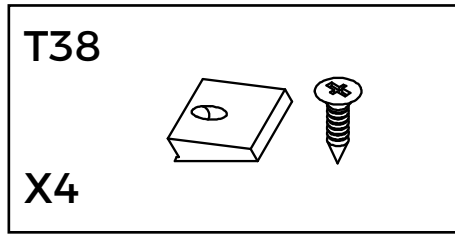

9

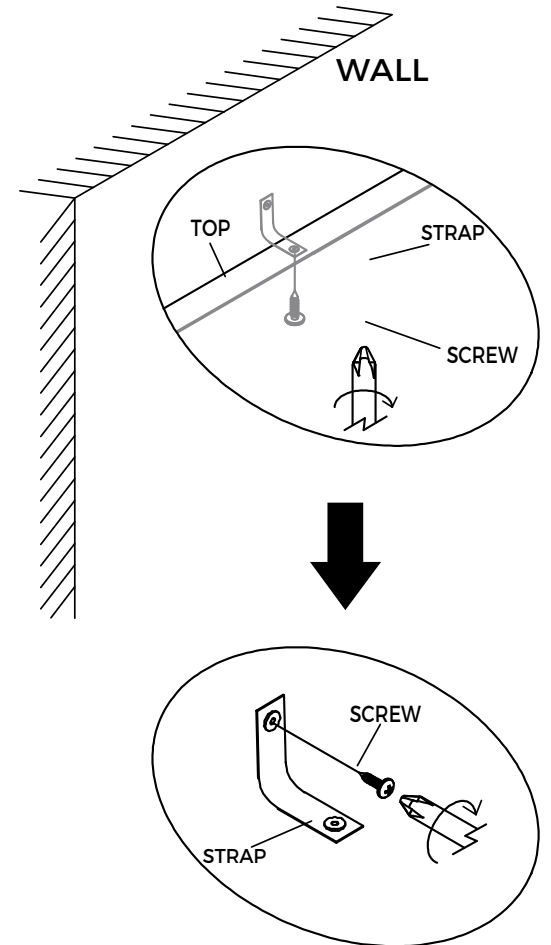
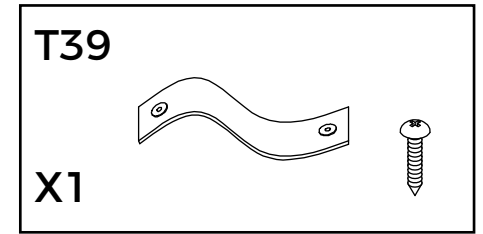
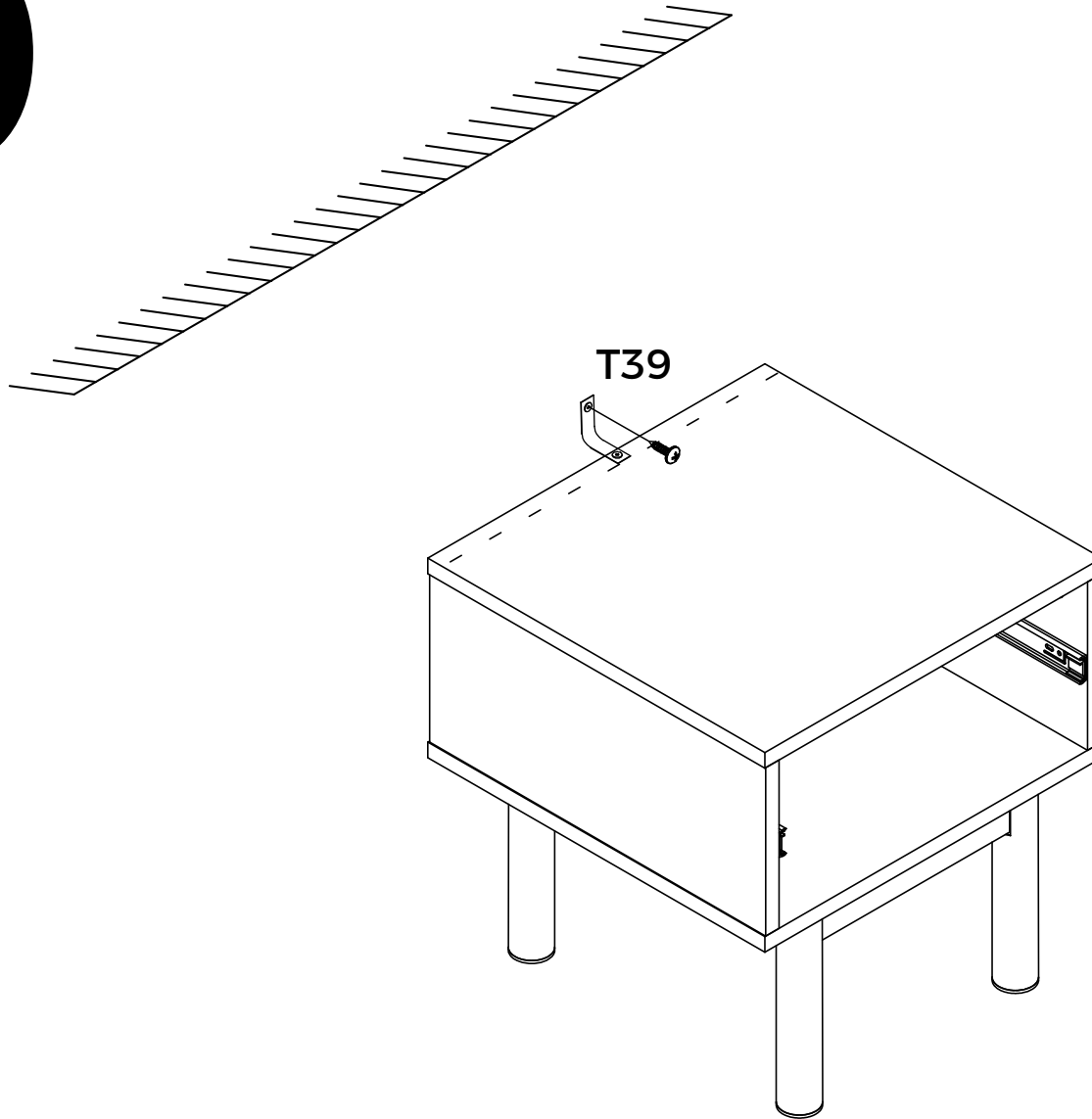

10

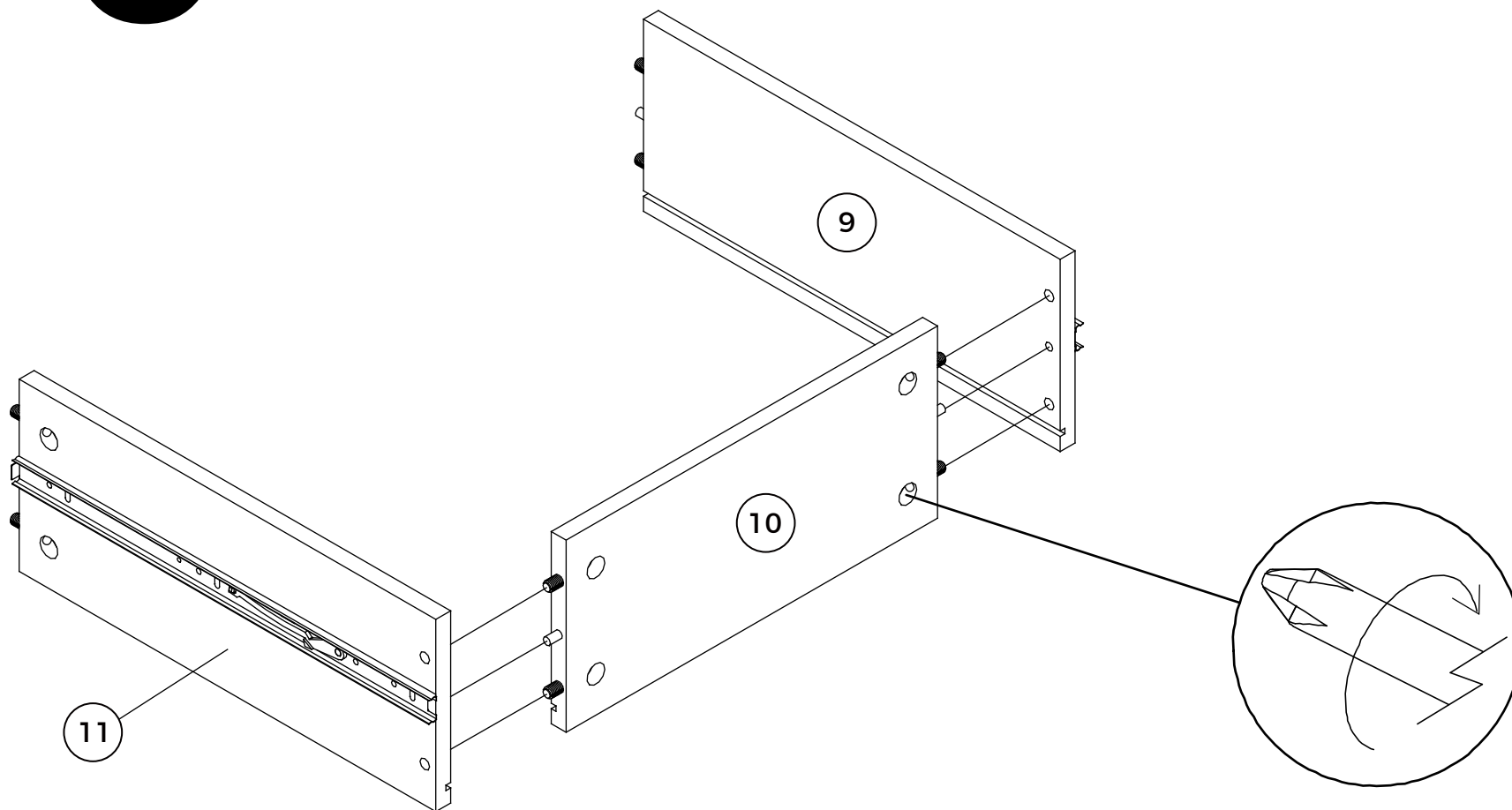
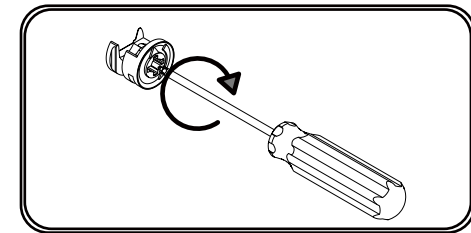

11

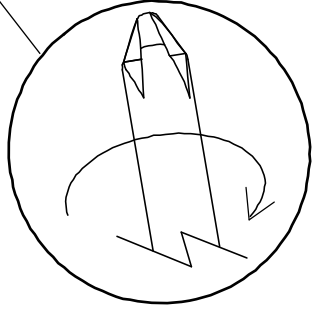
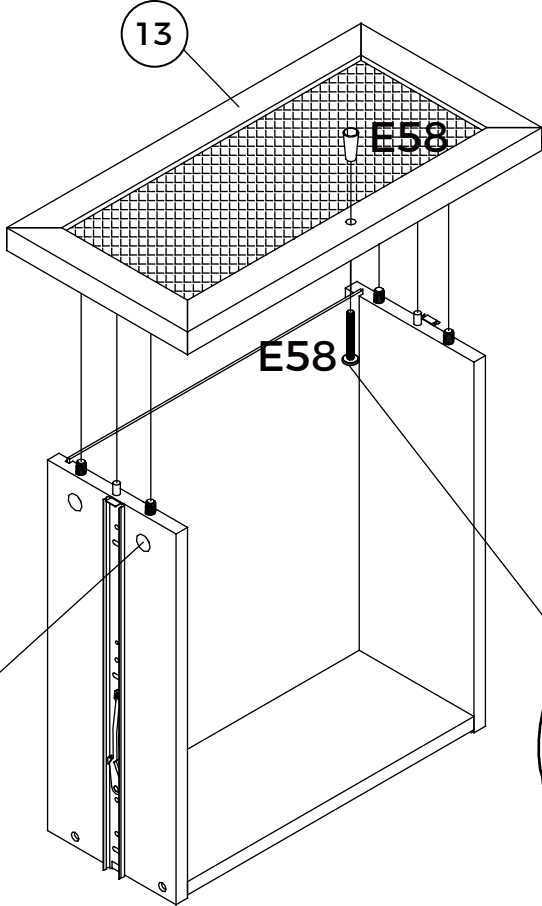
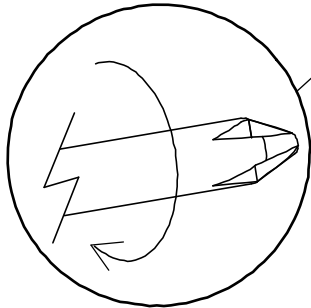
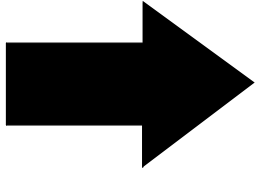
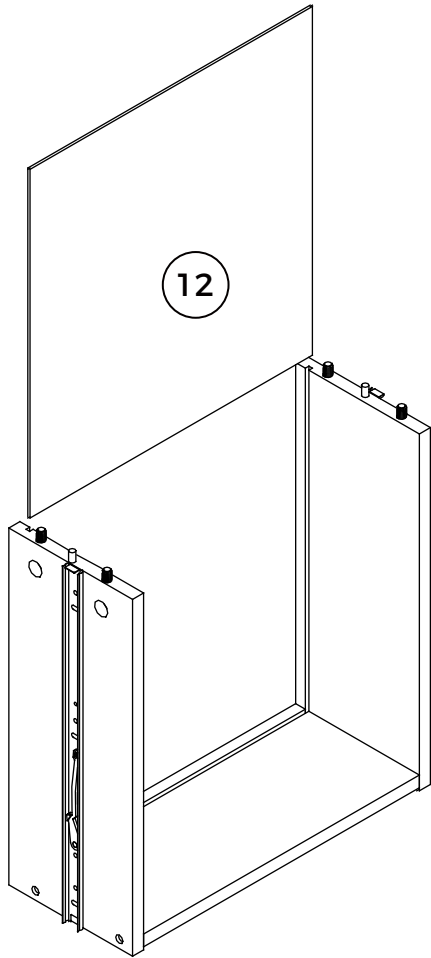
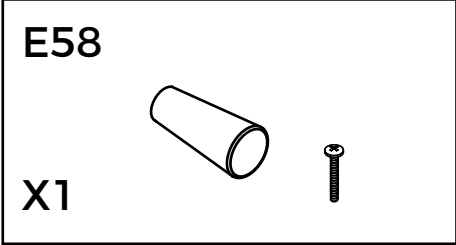
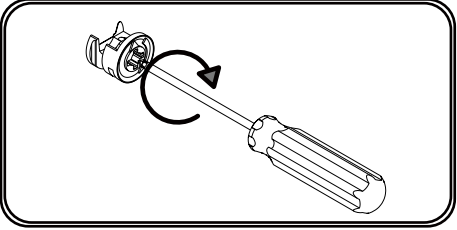

12

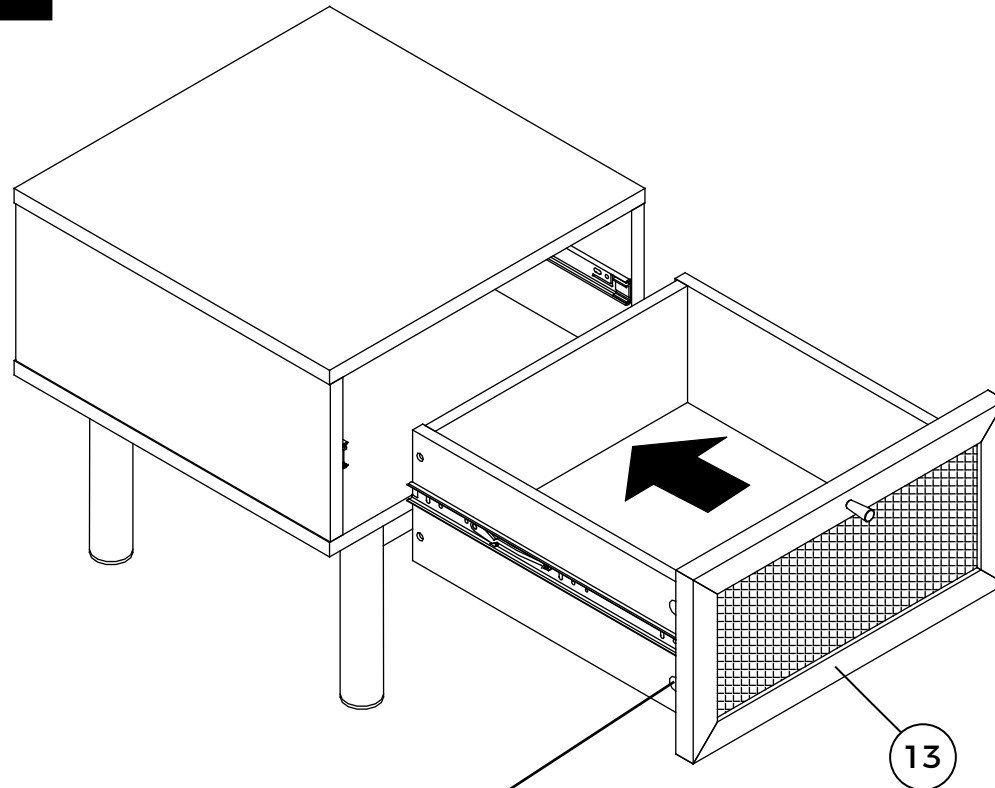
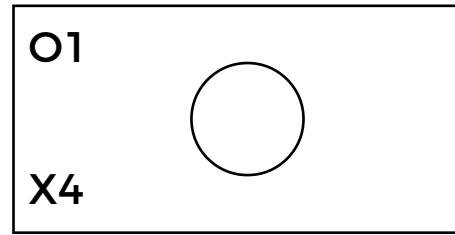

Please apply the stickers provided to cover the camlocks as shown on the diagram as an example.

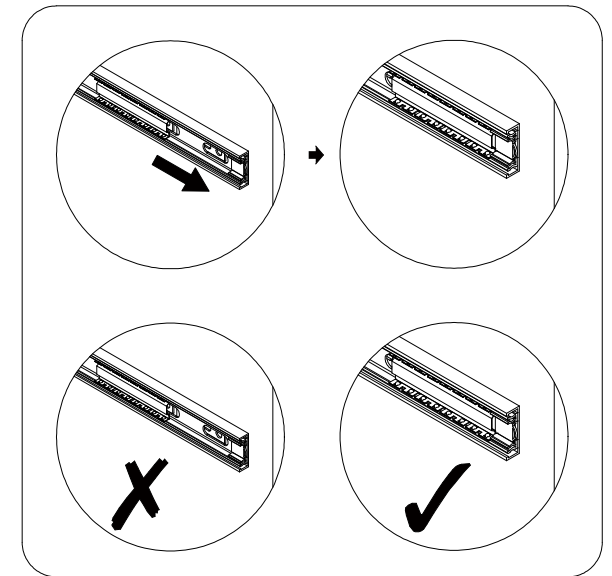
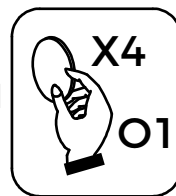

Left side

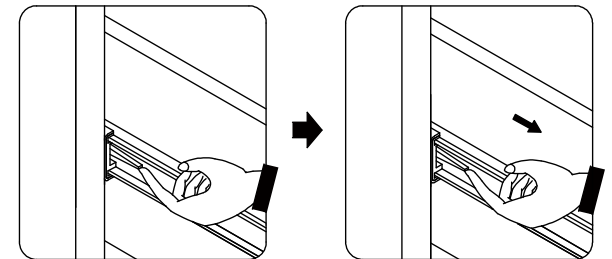

Right side

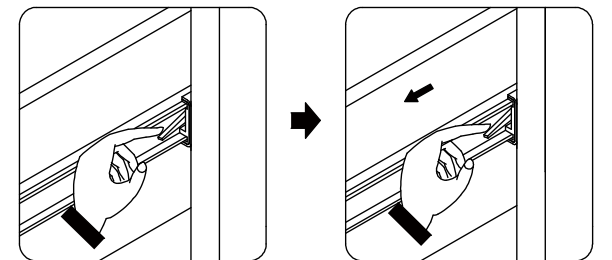

13

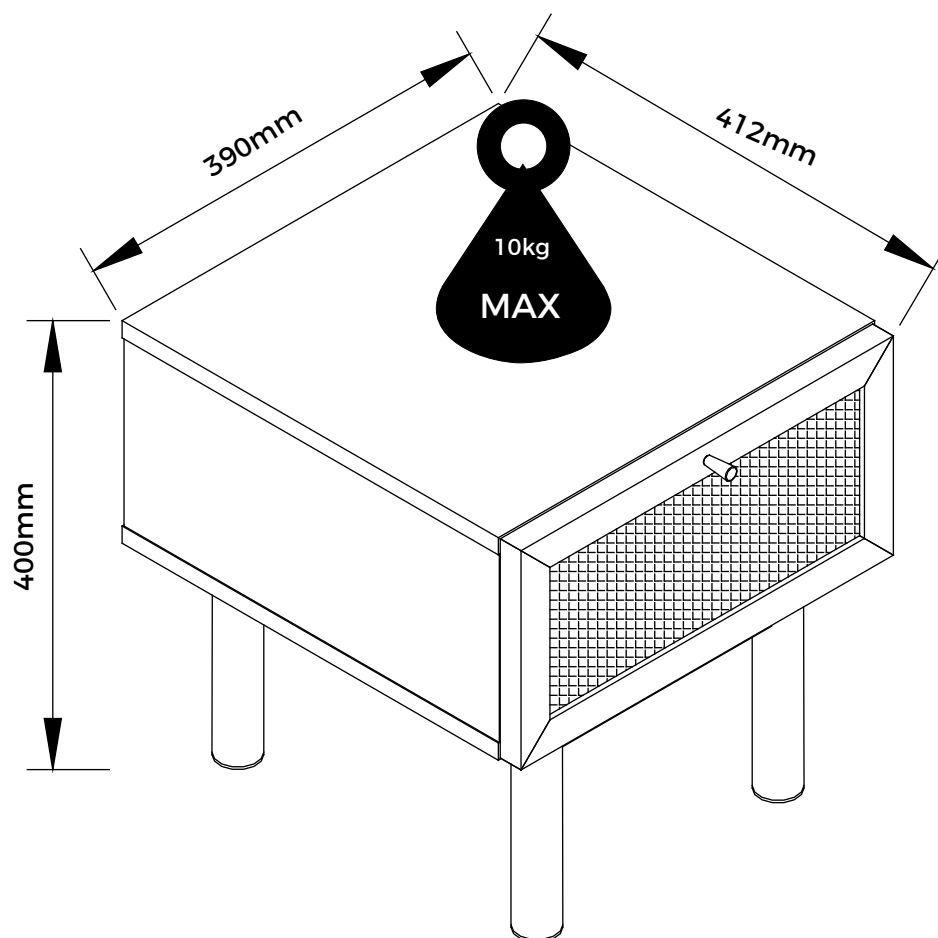
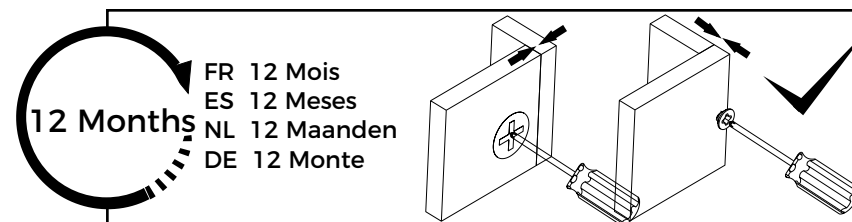

GB The unit must be fitted with the wall attachment and be secured prior to use. The unit must only be used on a level floor.

FR Le produit doit être équipé de la fixation murale et être fixé au mur avant toute utilisation. Le produit doit être utilisé sur hauteur de plancher.

ES La unidad debe estar equipada con el accesorio de pared y asegurarse antes de su uso. La unidad solo debe usarse en un piso nivelado.

NL Het meubel dient voor gebruik gemonteerd te worden aan de wand met het bijgeleverde materiaal. Dit meubel dient alleen op een even vloer gebruikt te worden.

DE Bringen Sie zuerst die Wandhalterung an und befestigen Sie das Produkt an der Wand, bevor Sie es verwenden. Stellen Sie das Produkt nur auf einem ebenen Untergrund auf.