

# BEFORE YOU GET STARTED...

*We're confident you'll love your gorgeous new Next furniture. However, it's worth making absolutely certain before you put it all together.*

*So, let's quickly run through these three steps:*

## 1. COLOUR

Make sure you're happy with the colour  
No need to unpack everything, just check the first component.

## 2. PROTECTIVE PACKAGING

If you're happy, then it's time to get opening! Start by laying everything out on the protective packaging – this will prevent anything getting scratched.

## 3. PARTS PAGE

Finally, double check you have all the pieces by referencing the parts page of the instructions.

## TIPS FOR RETURNS

Not completely happy with the product? No problem. We just need everything back in the original packaging, so follow the steps below and this will ensure a super-smooth returns process and no delay to your refund.

DO



- Check everything is there (the 'parts page' is a handy checklist).
- Pop all the loose fittings and fixtures into the packaging provided or tie them up in a plastic bag.
- Wrap all the big components back up in the original protective packaging.
- Close up the box and seal it securely (don't be afraid to use plenty of tape).

DON'T



- Leave anything assembled - all components should be dismantled and separately packed.
- Put loose fixtures and fittings straight into the box.
- Throw it back in the box carelessly – as it may get damaged.

next  
HOME

Then just give us a call on 0333 777 8999 and we'll sort out a pick up time for you.

next

# FLORENCE MULTI CHEST

529173

Assembly instructions

## Actual product size

H104xW100xD40cm

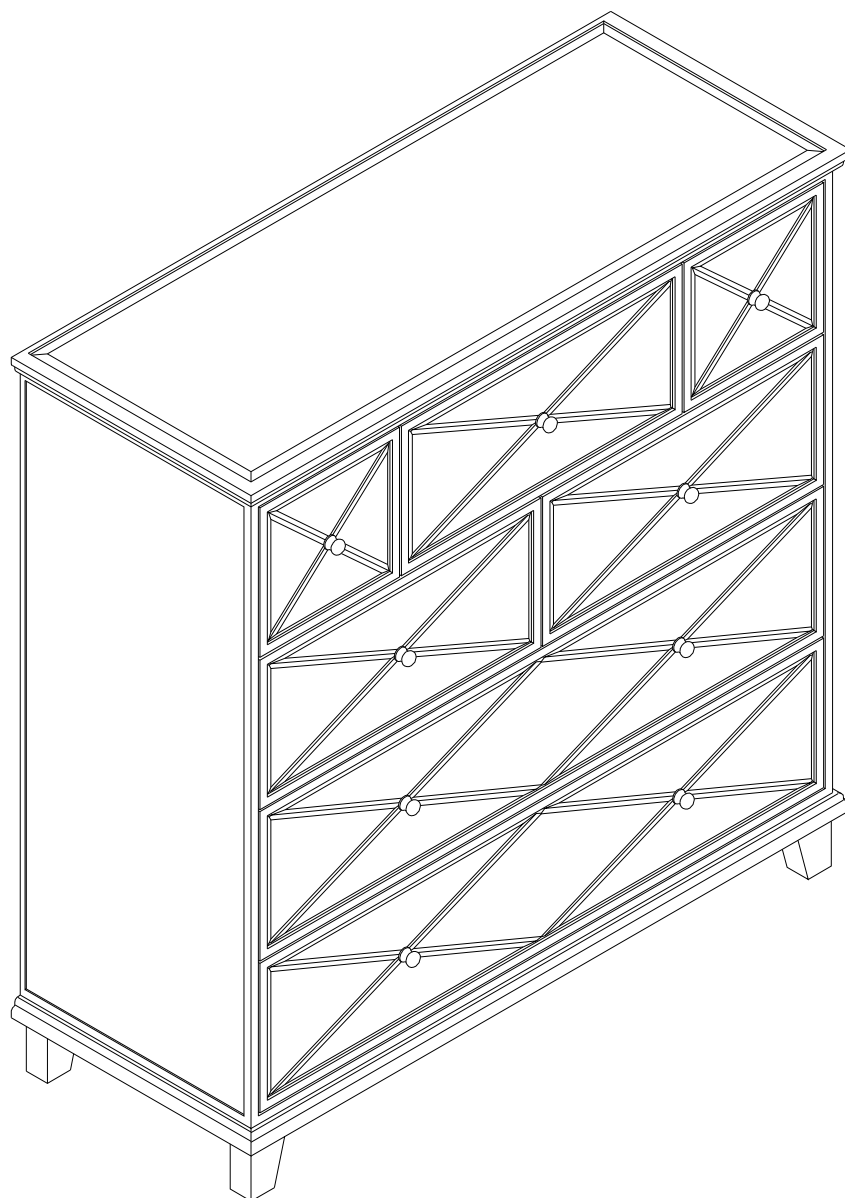

## Need Help?

With: Assembly instructions  
Missing or damaged parts

CALL:0333 777 8999

**IMPORTANT- RETAIN FOR FUTURE REFERENCE**

**BEFORE YOU START****Warnings**

We suggest you retain these instructions for future reference

Keep fittings out of children's reach and keep children well away from the construction area

This product should only be used on firm, level ground

For self-assembled products, please periodically check all fittings and re-tighten as necessary

Please do not sit or stand on your furniture

Avoid exposing the furniture to excessive heat or direct sunlight as this can cause deterioration of the colour

Unwrap all packaging materials and place the components on top of the carton box or on a clean floor to protect it from damage

**Do's**

We suggest you spend a short time reading through this leaflet before you start

When you are ready to start, make sure that you have the right tools and plenty of space

Unwrap all packaging materials and place the components on a clean surface to protect it from damage

For self-assembled products, we recommend that the packaging is used to protect the surfaces during assembly

Carefully check that you have all the parts before beginning assembly

Due to the size of the product we recommend that it is unpacked in the room intended for use

If the glass is chipped or broken, stop using the product and consult the supplier

When cleaning glass panels use a damp cloth with washing up liquid or soft soap if necessary. Do not use washing powders or any other substances containing abrasives since these substances scratch glass panel

The product complies with **BS 4875** and **BS EN 14749**

**PRODUCT SUPPLIED WITH WALL FIXING STRAPS****Don'ts**

Do not drag or pull your furniture

Do not use silicone based furniture polish. Silicone in furniture polishes can break down the finish

Do not place very hot or very cold items on the glass surface, unless adequately thick table mats or coasters are used to prevent such items from coming into contact with the glass

Do not use glass as a chopping surface. Do not strike the glass with hard or pointed items

**Number of people required to assemble**

Single person assembly

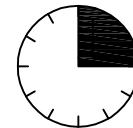
**Time to Assemble**

15 minutes

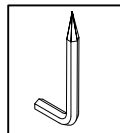
**Tools required**

supplied

**Missing parts**

If you are missing any fixtures and fitting for your product please contact our customer service team on 0333 777 8999 and they will be happy to arrange for a replacement to be sent to you free of charge.

**Home service technicians**

If you have a fault with your product please contact our customer service team on 0333 777 8999. If you have had the product for 28 days or less you may be offered a replacement, refund or for a fully trained home service technician to visit your home to assess the fault and repair the product where possible. If you have had the product for more than 28 days we will send an independent home service technician to review and repair the product where possible and recommend further action.

**You can write to us at**

Home Customer services  
Next Retail Ltd,  
Desford Road  
Leicester  
LE19 4AT

**To view our full furniture range please visit [www.next.co.uk](http://www.next.co.uk)**

## Tool supplied (not to scale)

REF	DIMENSIONS	VISUAL	QTY
A	60x20mm		1

\* Just to let you know we have included a small quantity of extra fittings, so don't worry if you've got a few left when you've finished.

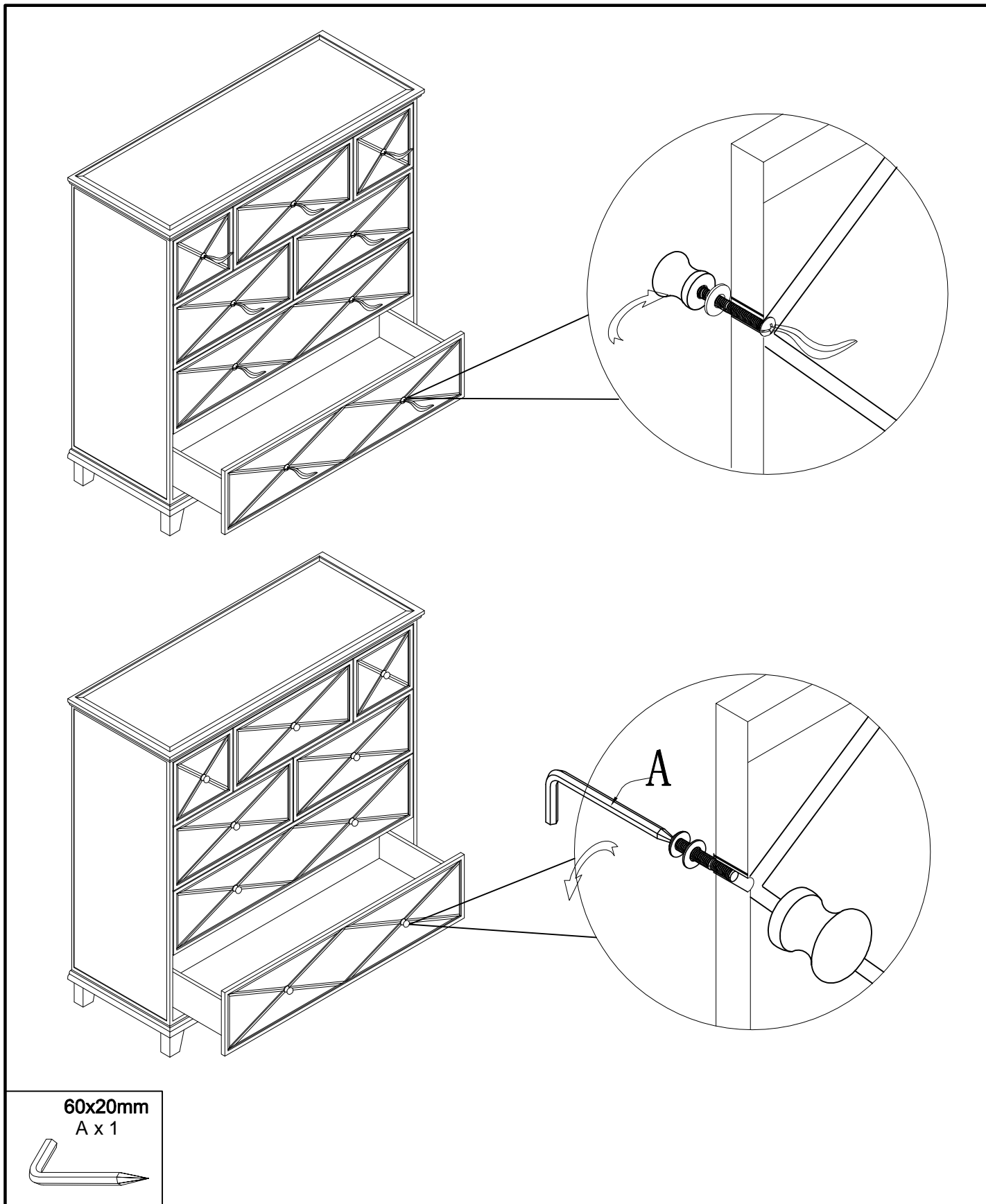

1

We recommend the use of the wall strap provided for safety reasons. Wall fixing are not included please source suitable fixing for your wall type. If in doubt, please consult a qualified tradesperson. **WARNING:** Always ensure the wall to be drilled is free from hidden electrical wires, water and gas pipes.

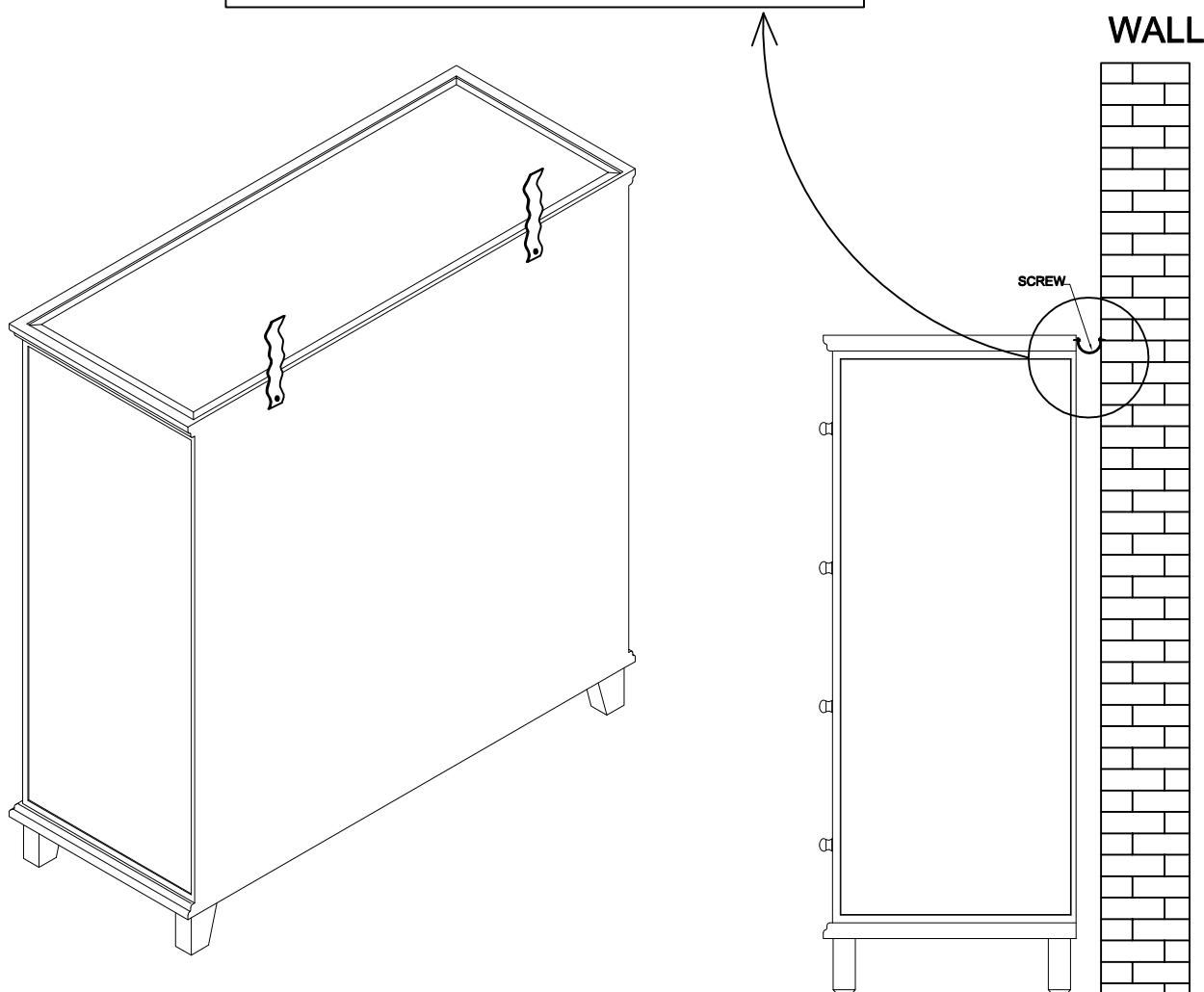
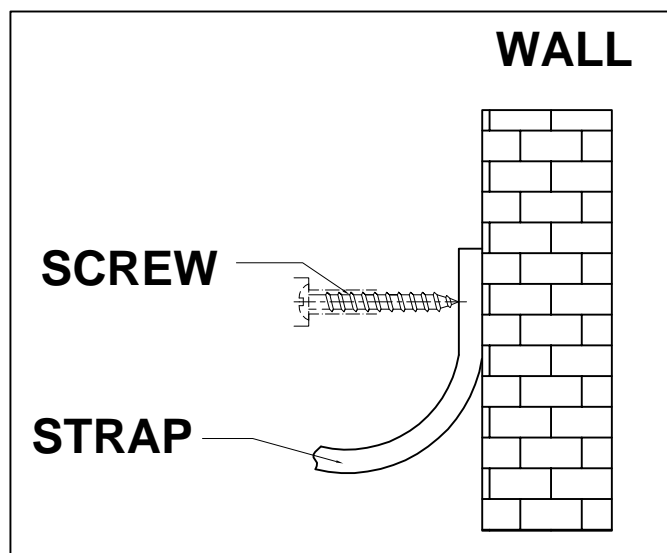

**Actual product size**

H104xW100xD40cm

