

BEFORE YOU GET STARTED...

We're confident you'll love your gorgeous new Next furniture. However, it's worth making absolutely certain before you put it all together.

So, let's quickly run through these three steps:

1. COLOUR

Make sure you're happy with the colour
No need to unpack everything, just check the first component.

2. PROTECTIVE PACKAGING

If you're happy, then it's time to get opening! Start by laying everything out on the protective packaging – this will prevent anything getting scratched.

3. PARTS PAGE

Finally, double check you have all the pieces by referencing the parts page of the instructions.

TIPS FOR RETURNS

Not completely happy with the product? No problem. We just need everything back in the original packaging, so follow the steps below and this will ensure a super-smooth returns process and no delay to your refund.

DO



- Check everything is there (the 'parts page' is a handy checklist).
- Pop all the loose fittings and fixtures into the packaging provided or tie them up in a plastic bag.
- Wrap all the big components back up in the original protective packaging.
- Close up the box and seal it securely (don't be afraid to use plenty of tape).

DON'T



- Leave anything assembled - all components should be dismantled and separately packed.
- Put loose fixtures and fittings straight into the box.
- Throw it back in the box carelessly – as it may get damaged.

next
HOME

Then just give us a call on 0333 777 8999 and we'll sort out a pick up time for you.

next

HELSINKI BLK 2SEATER

A09526

Assembly instructions

Actual product size

STEEL RATTAN DOUBLE SEAT CHAT CHAIR

SIZE:(H)146X(W)146X(D)102CM

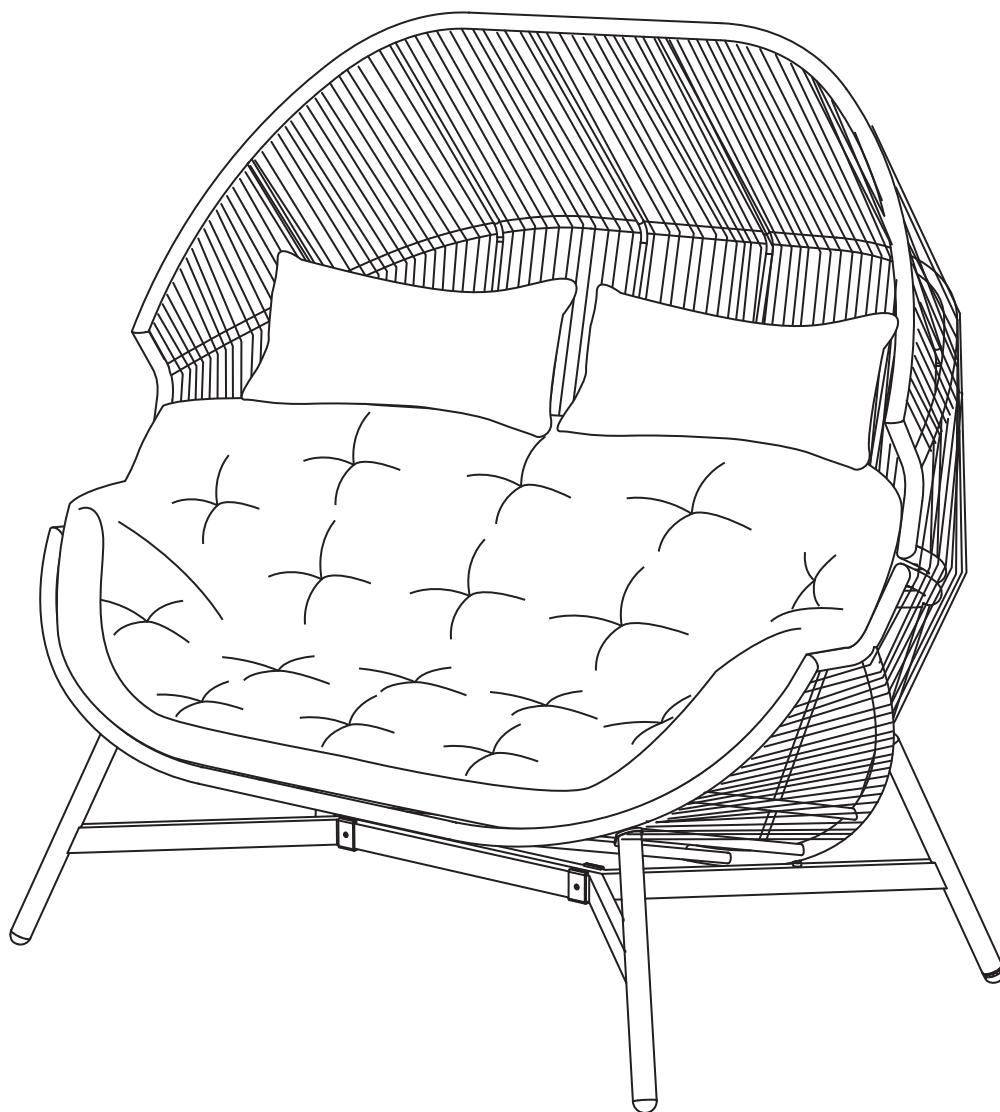

Need Help?

With: Assembly instructions
Missing or damaged parts

CALL: 0333 777 8999

IMPORTANT – RETAIN FOR FUTURE REFERENCE

BEFORE YOU START

WARNINGS

For domestic and outdoor use only.
 We suggest you retain these instructions for future reference
 Keep fittings out of children's reach and keep children well away from construction area.
 Please periodically check all fittings and re-tighten as necessary
 Please do not sit or stand on your table
 Unwrap all packaging materials and place the components on top of the carton box or on a clean floor to protect it from damage
 This product should only be used on firm, level ground. Make sure the legs remain in contact with the ground

Do's

We suggest you retain these instructions for future reference
 We suggest you spend a short time reading through this leaflet before you start
 When you are ready to start, make sure that you have the right tools and plenty of space
 Unwrap all packaging materials and place the components on a clean surface to protect it from damage, We recommend that the packaging is used to protect the surfaces during assembly
 Carefully check that you have all the parts before beginning assembly
 Please retain the assembly tools. You will need them in the future to re-tighten the bolts, or if you want to dismantle the furniture for storage.
 Please make sure that the product is clean and dry before putting it into storage.
 We recommended the use of furniture covers to protect your furniture when not in use. During severe weather conditions, please move your furniture inside
 To clean your items, please use mild detergent in warm water. Rinse with clean water and dry thoroughly. Do not use abrasive cleaners, strong detergents, bleach, acid or solvents on the frame parts

Don'ts

Do not stand on your chair.
 Do not sit on the arms of your chair. (Note: arm chair only)
 When moving furniture never drag the pieces across the floor, as this will cause damage to the joints
 Please do not leave your product outside when not in use.
 During bad weather and winter months the product should be dismantled and stored in a cool dry place.
 Do not use silicone based furniture polish

Number of people required to assemble

Two persons are required to assemble this item.

Time to assemble

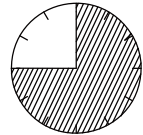

45 Mins

Missing parts

If you are missing any fixtures and fittings for your product please contact our customer service team on 0333 777 8999 and they will be happy to arrange for a replacement to be sent to you free of charge.

Home service technicians

If you have a fault with your product please contact our customer service team on 0333 777 8999. If you have had the product for 28 days or less you may be offered a replacement, refund or for a fully trained home service technician to visit your home to assess the fault and repair the product where possible. If you have had the product for more than 28 days we will send an independent home service technician to review and repair the product where possible and recommend further action.

You can write to us at

Home Customer Services
 Next Retail Ltd,
 Desford Road,
 Leicester,
 LE19 4AT

To View our full furniture range please visit www.next.co.uk

GETTING TO KNOW YOUR PRODUCT

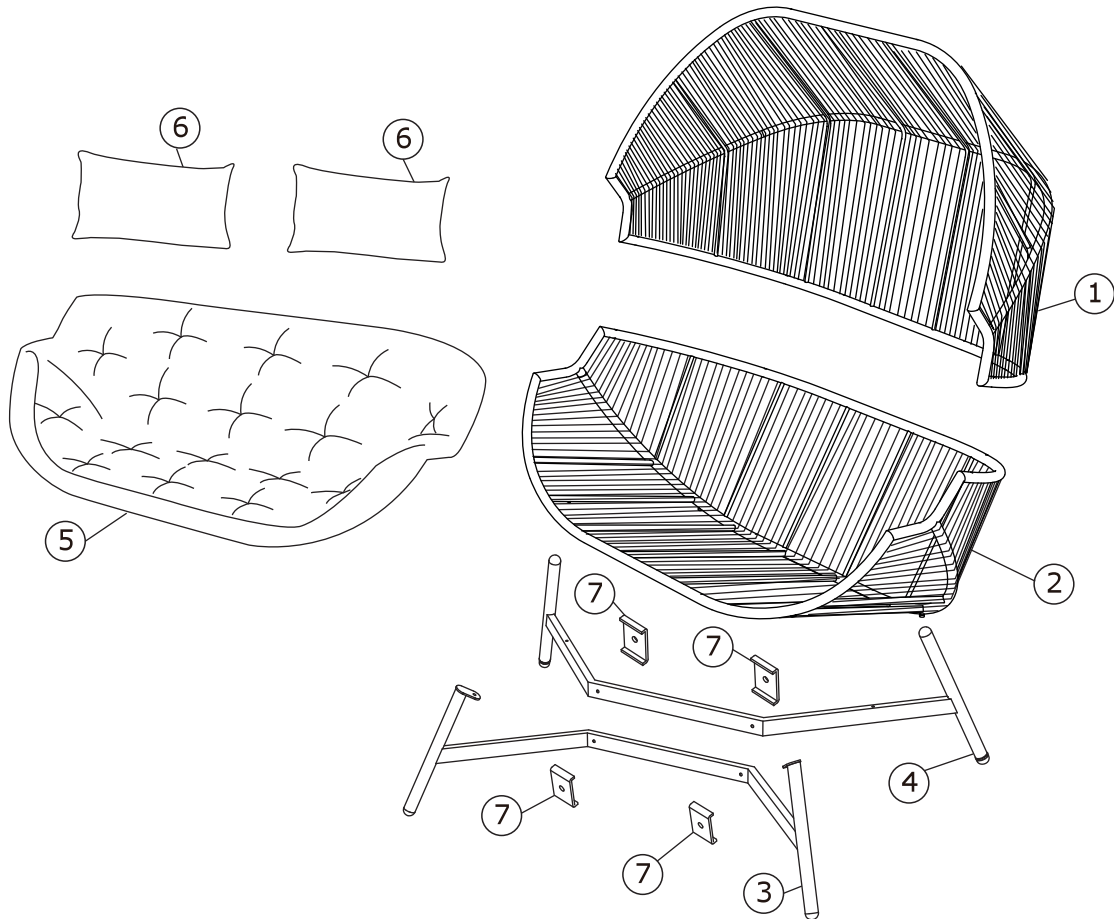







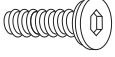

Components supplied. Please use this guide if you require replacement parts.

Ref	Visual	Qty	Ctn
1		1	1
2		1	1
3		1	1
4		1	1

Ref	Visual	Qty	Ctn
5		1	1
6		2	1
7		4	1

Fixtures and fittings supplied (not to scale)

Ref	Visual	Qty	* Extra Fittings
A	 M6x65MM	4	1
B	 M6x55MM	4	1
C	 M6x20MM	2	1
D		16	2
E		6	1
G		6	1
H		1	N/A
I		1	N/A

1

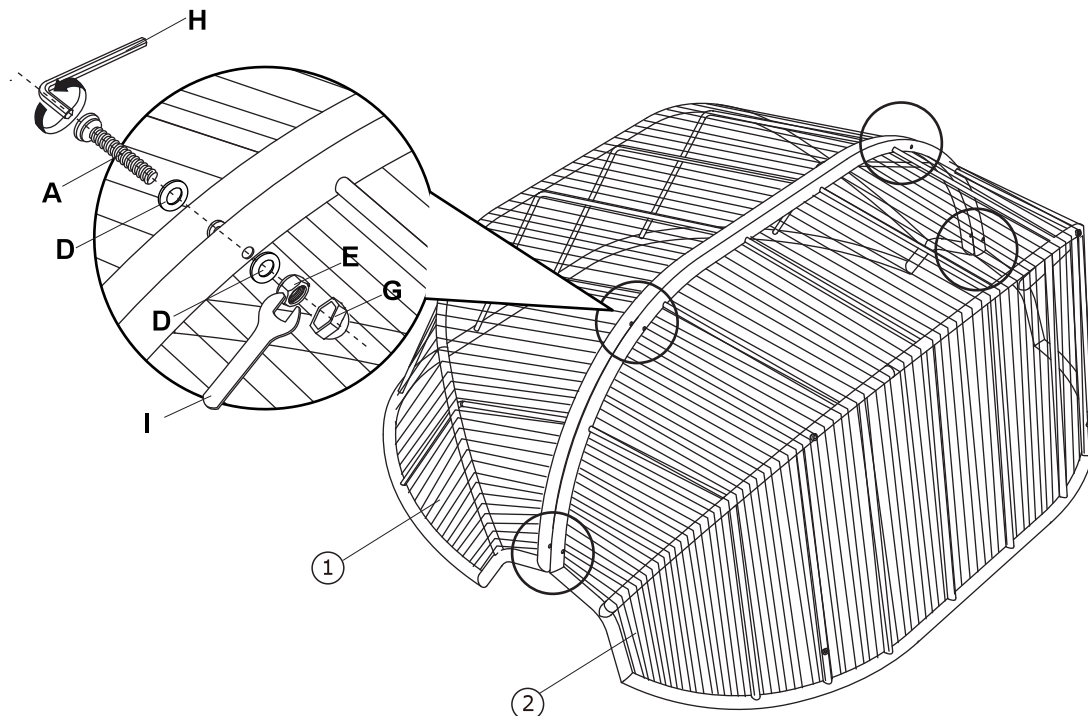

2

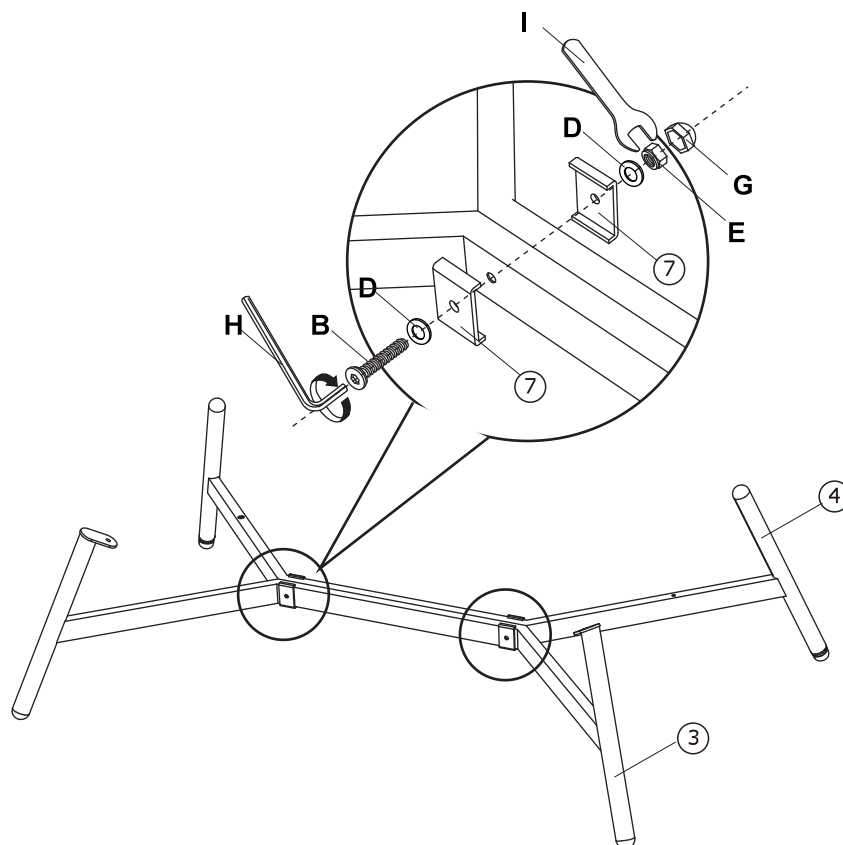

3

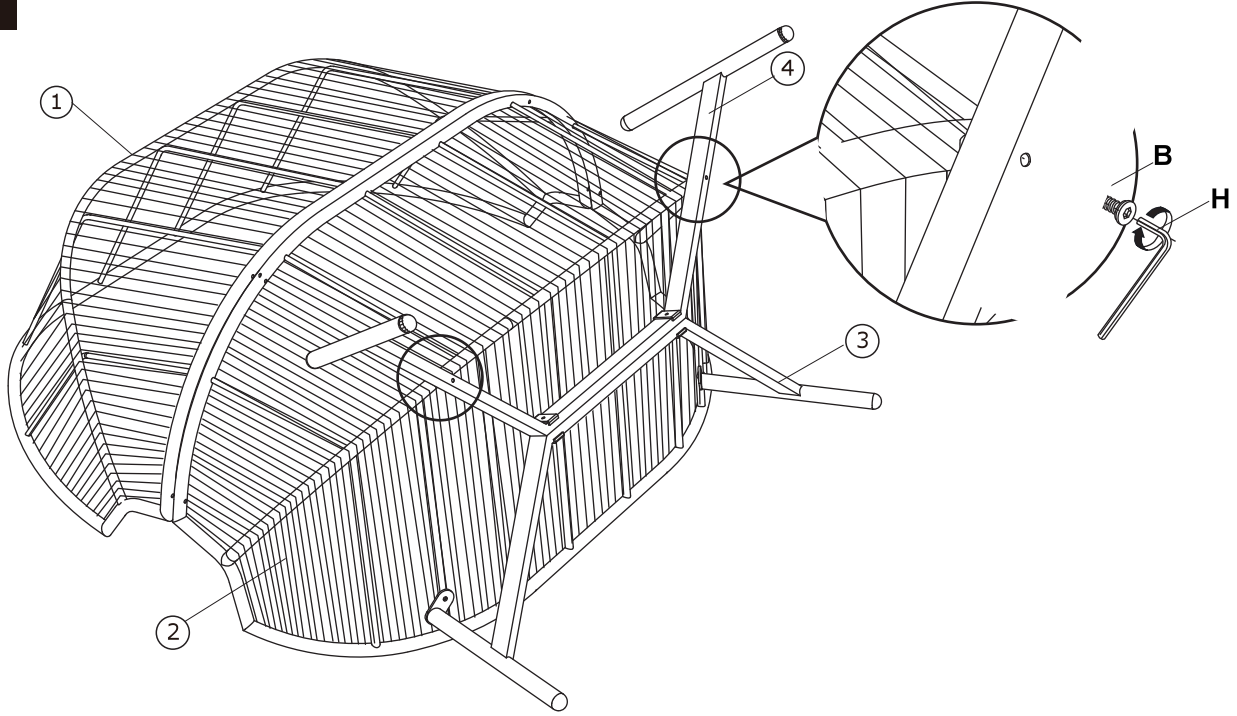

4

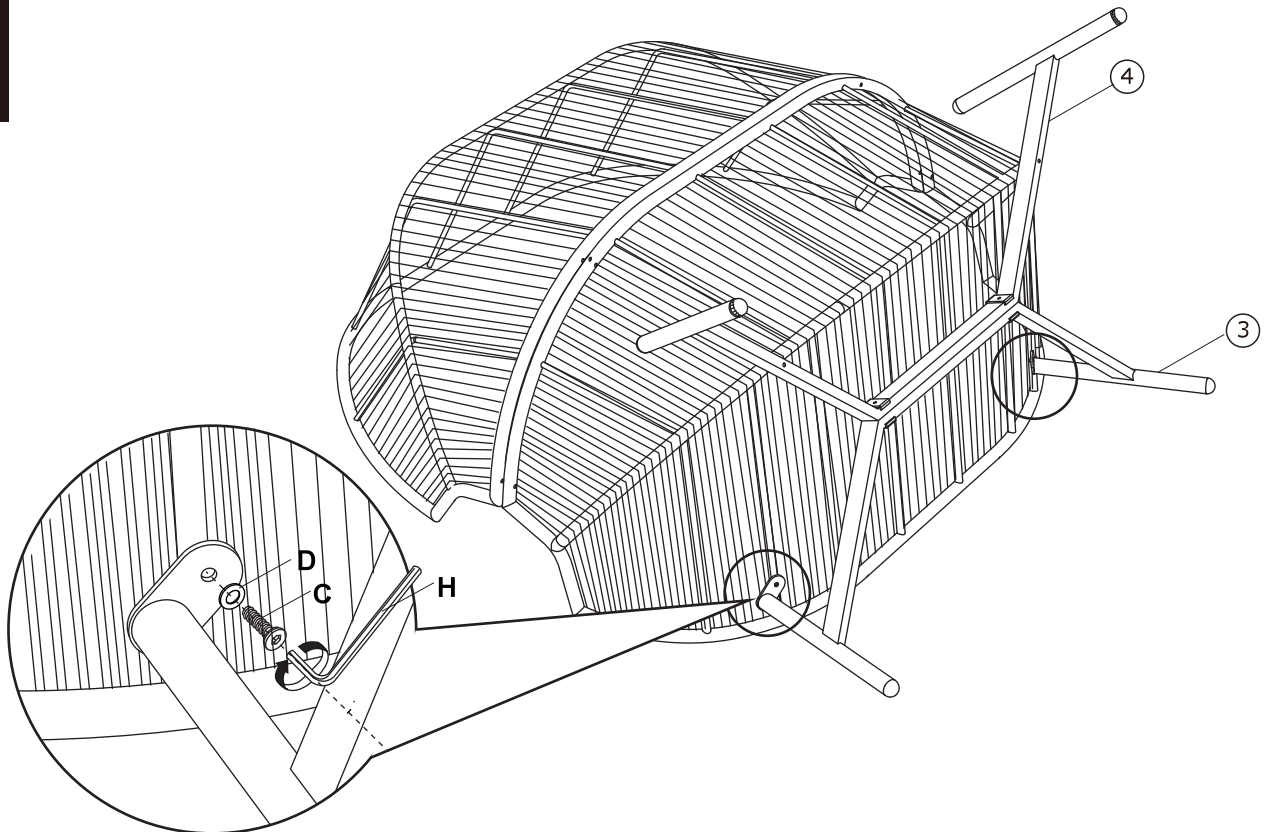

5

