

**NEXT**

Thank you for shopping with us

# NEXT

## JACKSON 3 LIGHT FLUSH

A98729

### Assembly Instructions

**Actual Product Size**  
Ø450\*H200mm

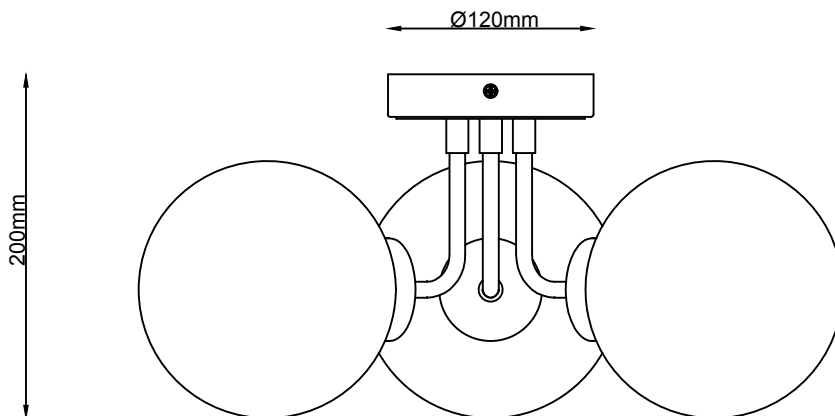
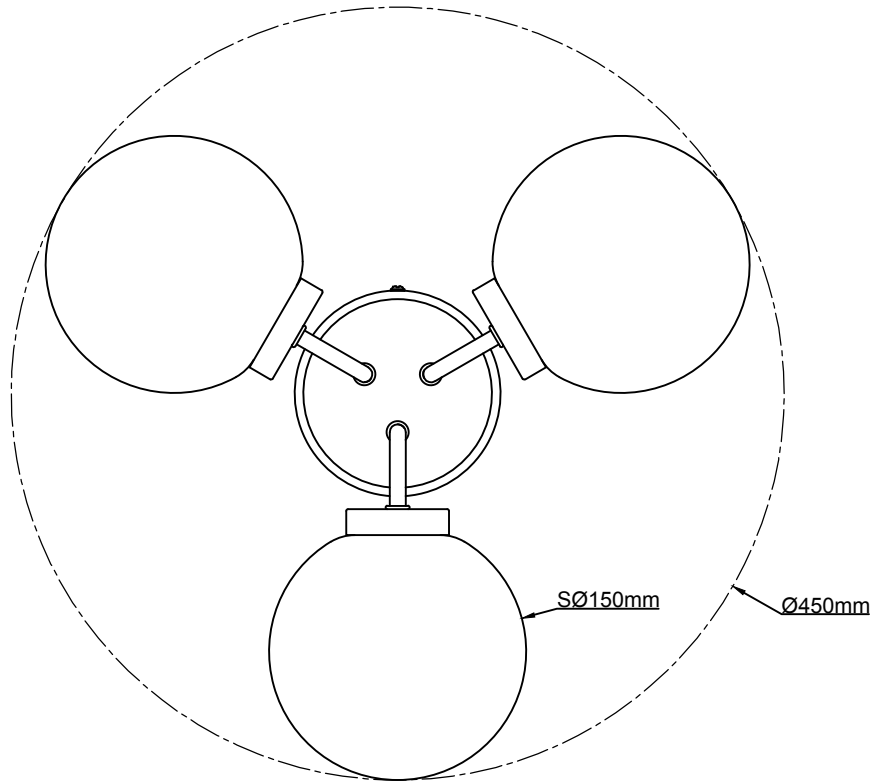

**IMPORTANT - RETAIN FOR FUTURE REFERENCE**

### Need Help?

with: Assembly instructions,  
missing or damaged parts

**CALL:0333 777 8999**

# NEXT

## JACKSON 3 LIGHT FLUSH

A98729

### Assembly Instructions

## BEFORE YOU START

### Warnings

We suggest you retain these instructions for future reference

For your safety, this product must be installed in accordance with local Building Regulations. If in any doubt, or required by the law, consult a competent person who is registered with an electrician self-certification scheme. Further information is available online or from your Local Authority

This light is suitable for indoor use only

Light fittings should be connected to a 5 amp fused circuit

Before commencing installation, isolate the circuit to be used by removing the fuse or circuit breaker at the consumer distribution unit

### Do's

We suggest you spend a short time reading through this leaflet before you start

When you are ready to start, make sure that you have the right tools and plenty of space

Unwrap all packaging materials and place the components on top of the carton box or on a clean floor to protect it from damage

We recommend that the packaging is used to protect the surfaces during assembly

Carefully check that you have all the parts before beginning assembly

Ensure the product is fully assembled as illustrated and all fixings fully tightened before use. Check fixings regularly to ensure they remain tight

Always switch off the supply before changing light bulbs or cleaning

Allow bulbs to cool down before handling

Use 3 x SES Max 7W LED bulb (bulb not included)

### Don'ts

The fitting should not be fixed to newly painted or plastered surfaces as this may cause discolouration of the finish

We recommend cleaning with a soft dry cloth, do not use abrasive materials as these will rub away the protective coating.

### Number of people required to assemble

One person who is competent with electrical wiring and installation, however we do recommend that this item is installed by a qualified electrician

### Time to assemble

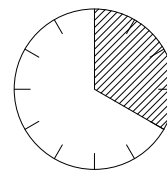

20mins

### Tools required

Cross Head Screwdriver  
Flat Screwdriver  
Insulating Tape

### Missing parts

If you are missing any fixtures and fittings for your product please contact our customer service team on 0333 777 8999 and they will be happy to help.

### Cleaning Care

We recommend cleaning with a soft dry cloth. Do not use abrasive materials as these will rub away the protective coating.

### Maintenance

To ensure your safety, if the cable becomes damaged it must be replaced only by a qualified person.

### Safety information

For your safety, please remember the following:

- Always switch off the power supply before changing light bulbs or cleaning .
- Allow bulbs to cool down before handling.

### You can write to us at

Home Customer Services  
Next Retail Ltd,  
Desford Road,  
Leicester,  
LE19 4AT  
or  
Next Retail (Ireland) Ltd,  
13-18 City Quay,  
Dublin 2,  
D02 ED70

To view our full range please visit  
[www.next.co.uk](http://www.next.co.uk)

## GETTING TO KNOW YOUR PRODUCT

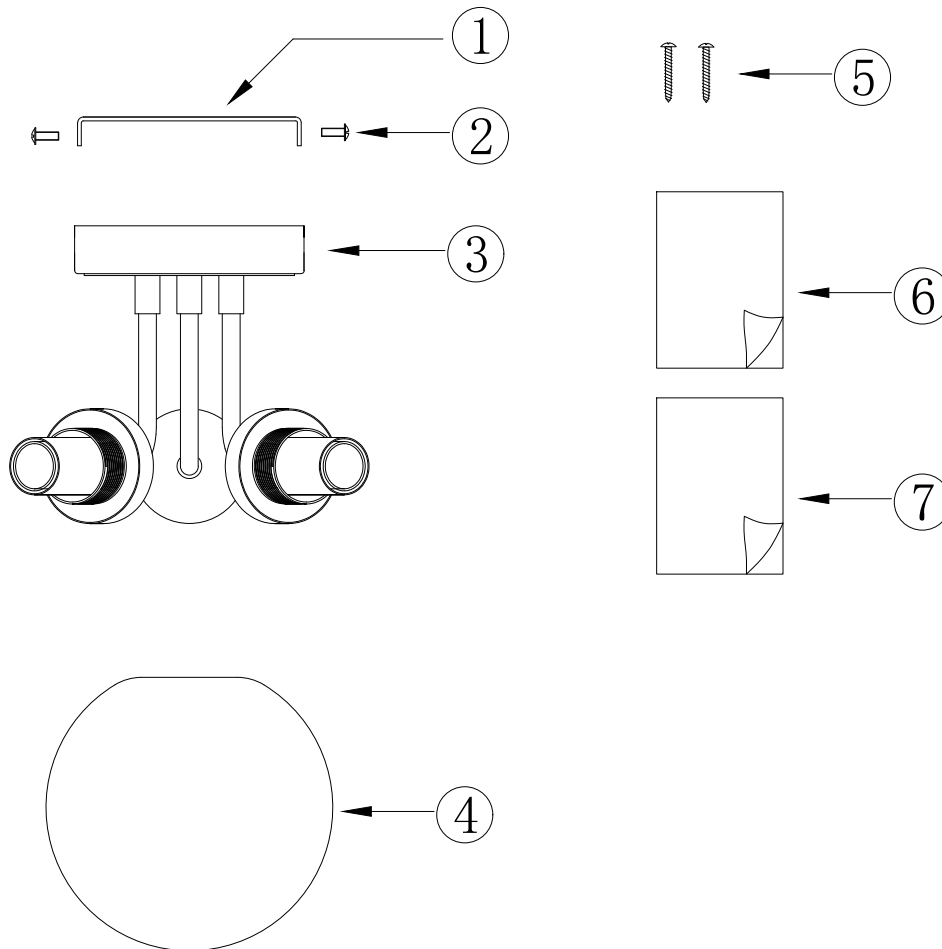

Ref	Description	Specification	Qty	Remark
1	Fixing bracket	L117*W20*H15MM	1	Attached on light fitting
2	Fixing bracket screws	M4*L10MM	2	Attached on light fitting
3	Light fitting		1	
4	Lamp shade	Φ150*H143MM	3	Packed in carton
5	Fixing screws	L38MM	2	Packed in fixing pack
6	Assembly instructions	A3 X 2	1	Packed in fixing pack
7	Re-package instruction	A4 X 1	1	Packed in fixing pack

# NEXT JACKSON 3 LIGHT FLUSH

## A98729

### Assembly Instructions

1

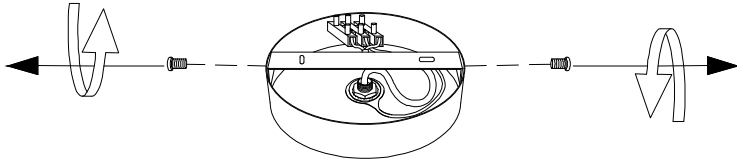

#### Step 1

Using the mounting strap as a guide, mark screw positions on the ceiling. Make sure the area is free of any hidden wires, water or gas pipes.

2

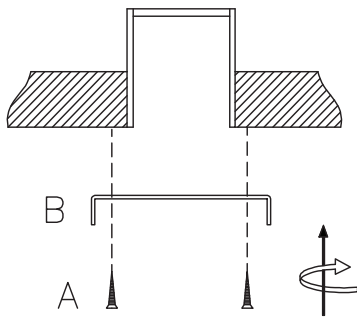

#### Step 2

Attach fixing bracket to the ceiling using screws supplied.

3

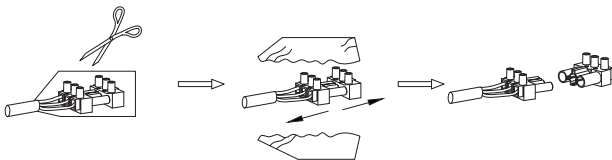

#### Step 3

When you are ready to connect your fitting to the electricity supply, carefully remove any clear plastic sleeve around the terminal block using a pair of scissors. Take care not to damage the wiring or terminal block while removing the sleeve. Then separate the female part from the male part and retain it for later use.

4

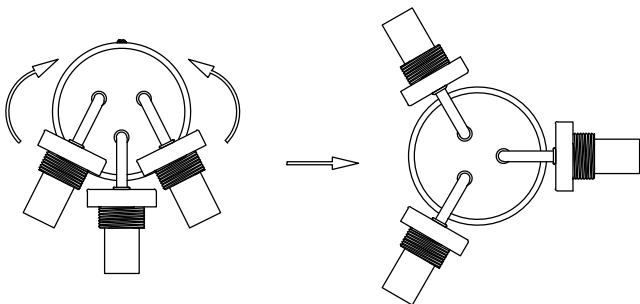

#### Step 4

Unfold the arms as shown, make sure they are equidistant.

# NEXT JACKSON 3 LIGHT FLUSH

## A98729

### Assembly Instructions

4

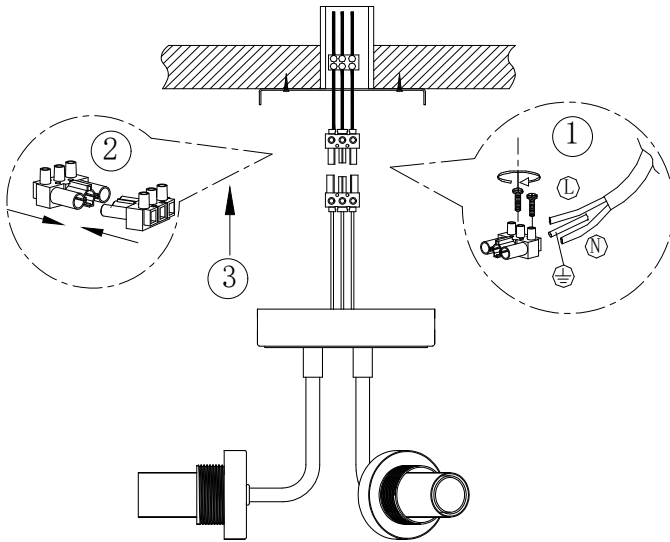

#### Step 4

First, connect the wires from building as image 1 shows. Second, connect two parts to the connect terminal block. Third, whilst supporting the weight of the light, connect household and fitting wires according to the diagram.

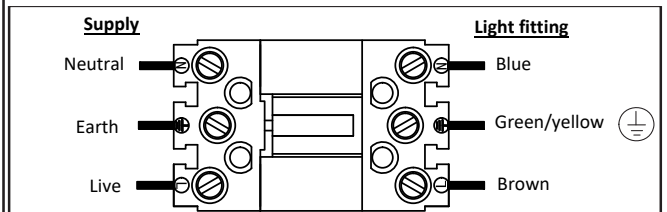

Ensure that connections are tight and that no loose strands are left out of the connectors. Cover the connectors with two layers of good quality electrical insulation tape continuing at least 2cm either side of the connector block.

5

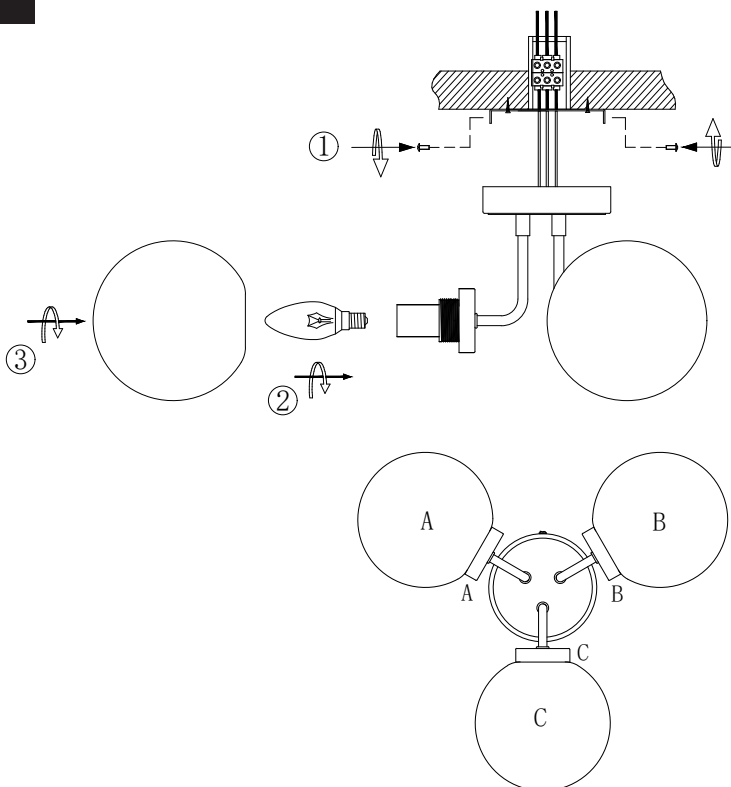

#### Step 5

Attach ceiling plate to the mounting strap using fixing bracket screws. Fit the bulbs. Do not exceed the stated maximum wattage. Attach the lamp shade onto lampholder (follow the sequence A/B/C) and secure into position .