

MADE⁺

Tulma

Large Sideboard

Grand buffet

Groot dressoir

Groses Sideboard

Aparador grande



GB Recommendations for the continual safe use of this product are stated on the final page of these instructions. Please retain for future reference.

FR Les conseils d'utilisation de ce produit sont indiqués sur la dernière page de ces instructions. Veuillez les conserver pour vous y référer si besoin.

NL Aanwijzingen voor veilig gebruik van dit meubel worden toegelicht op de laatste pagina van deze instructies. Bewaar deze folder goed.

DE Auf der letzten Seite dieser Anleitung findest du Hinweise für eine langfristig sichere Anwendung dieses Produktes. Bitte bewahre sie gut auf.

ES Las recomendaciones para el uso continuado de este producto figuran en la última página de estas instrucciones. Por favor, consérvalas para futuras consultas.

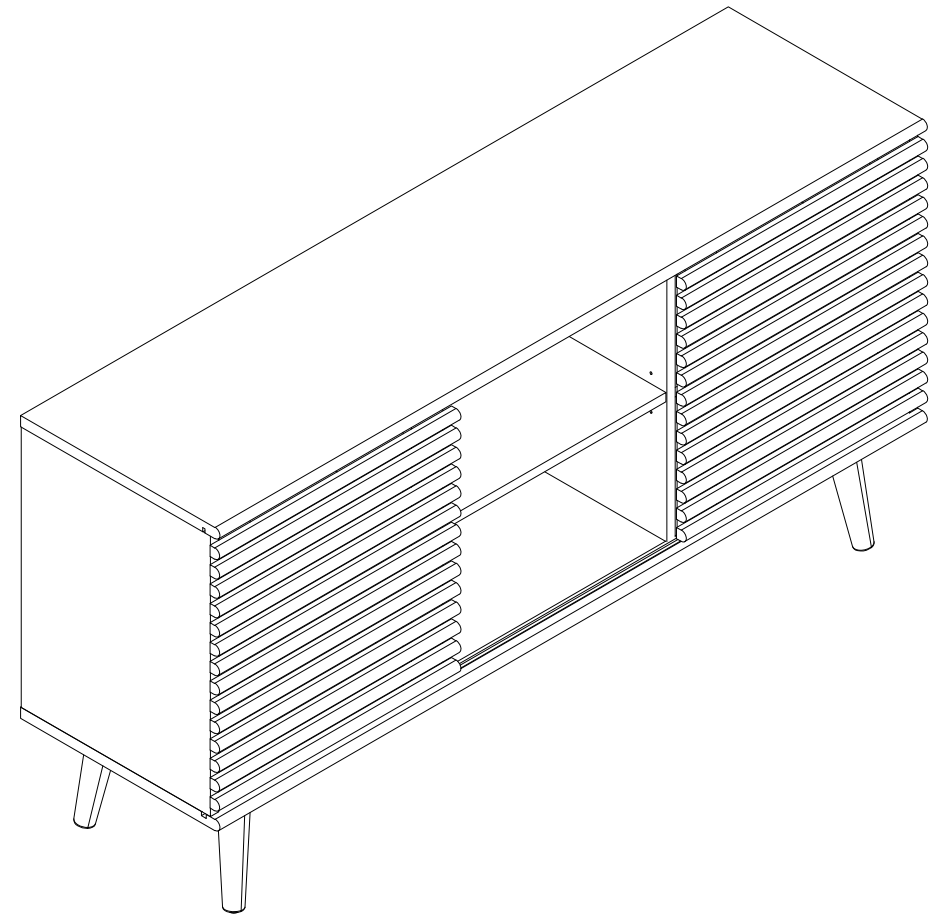

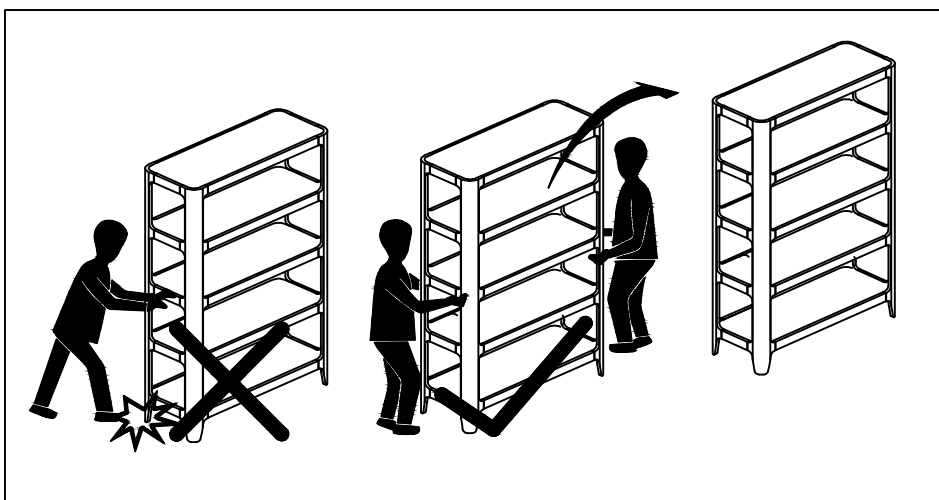
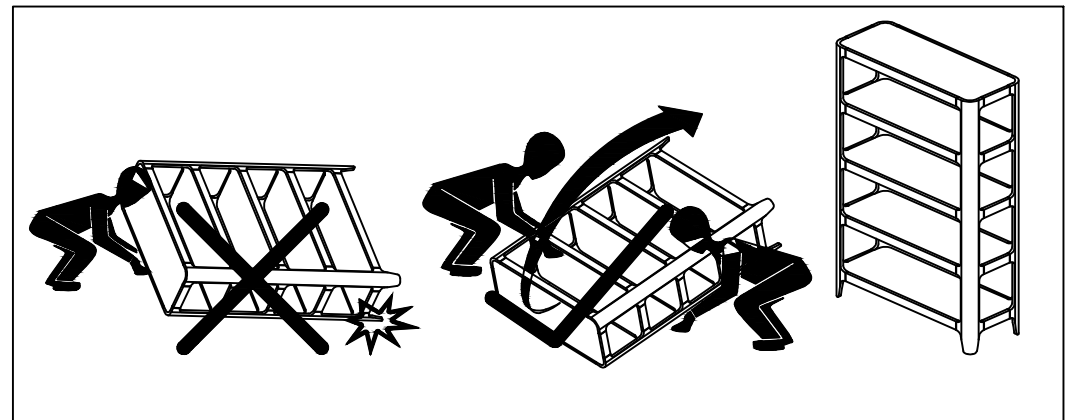
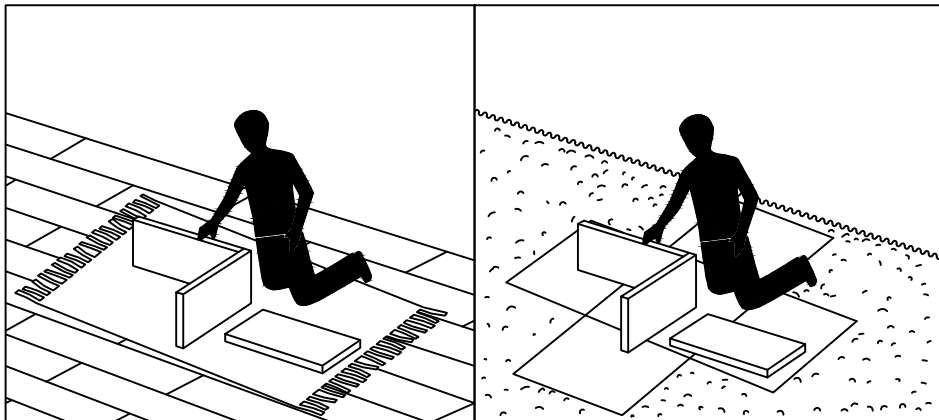
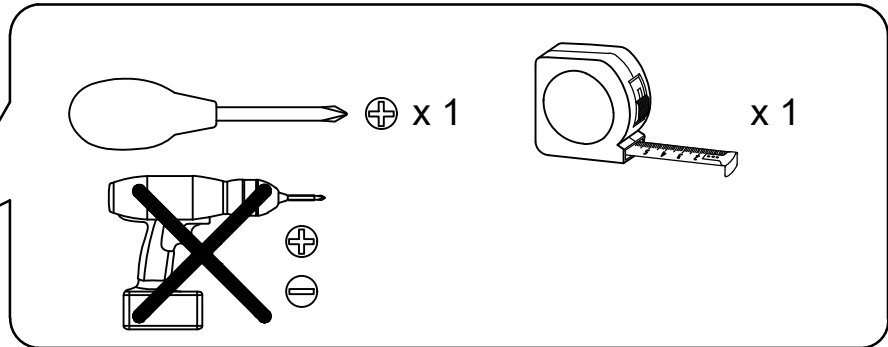
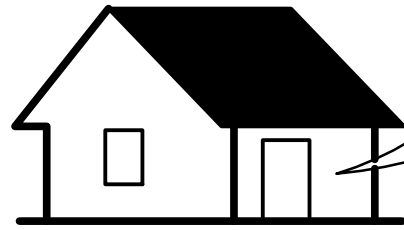
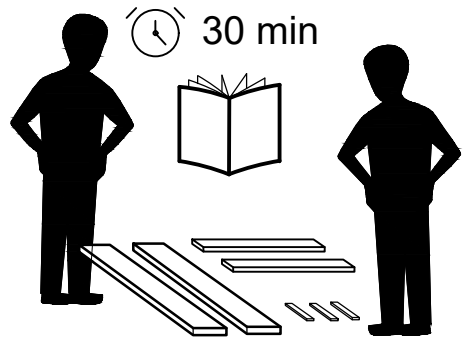

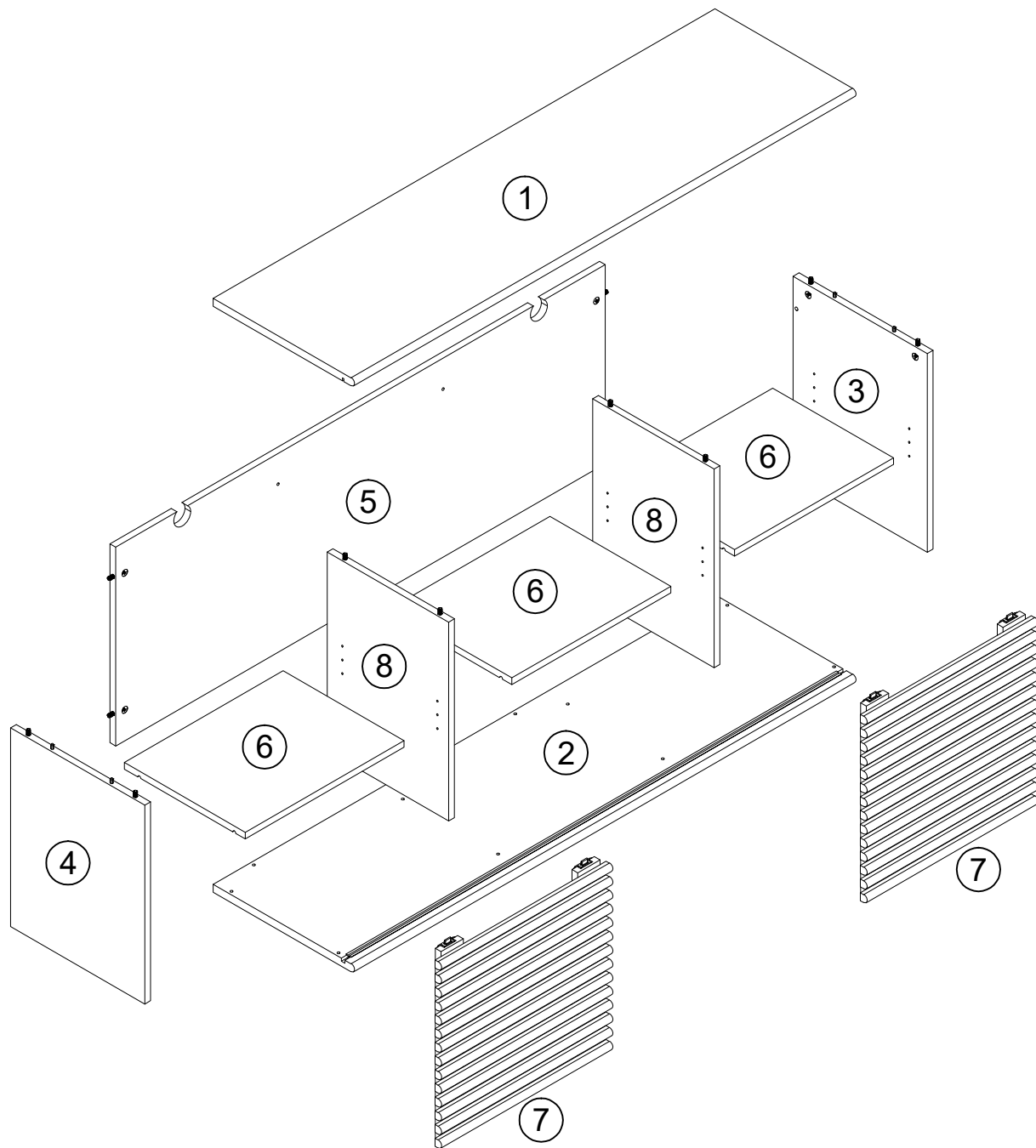

a x 14

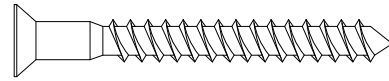

Ø5 x 50mm

b x 4

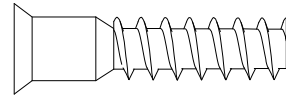

Ø7 x 40mm

i x 12



Ø4 x 18mm

o x 2

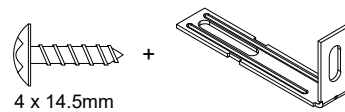

4 x 14.5mm

v x 1

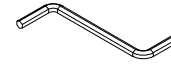

y x 1

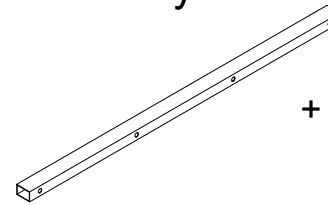

+



x 2Pcs

z x 4

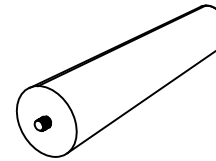

1

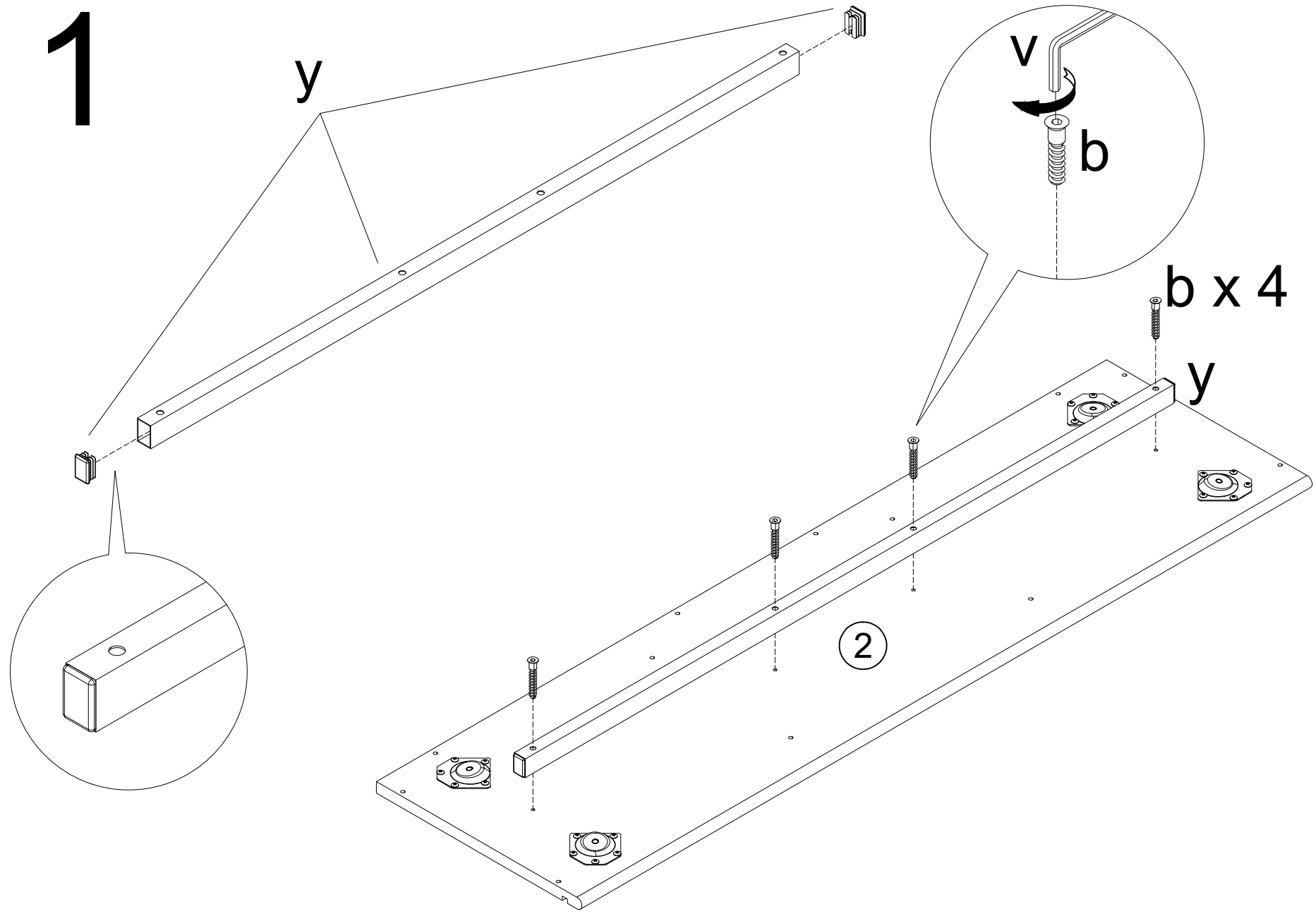

2

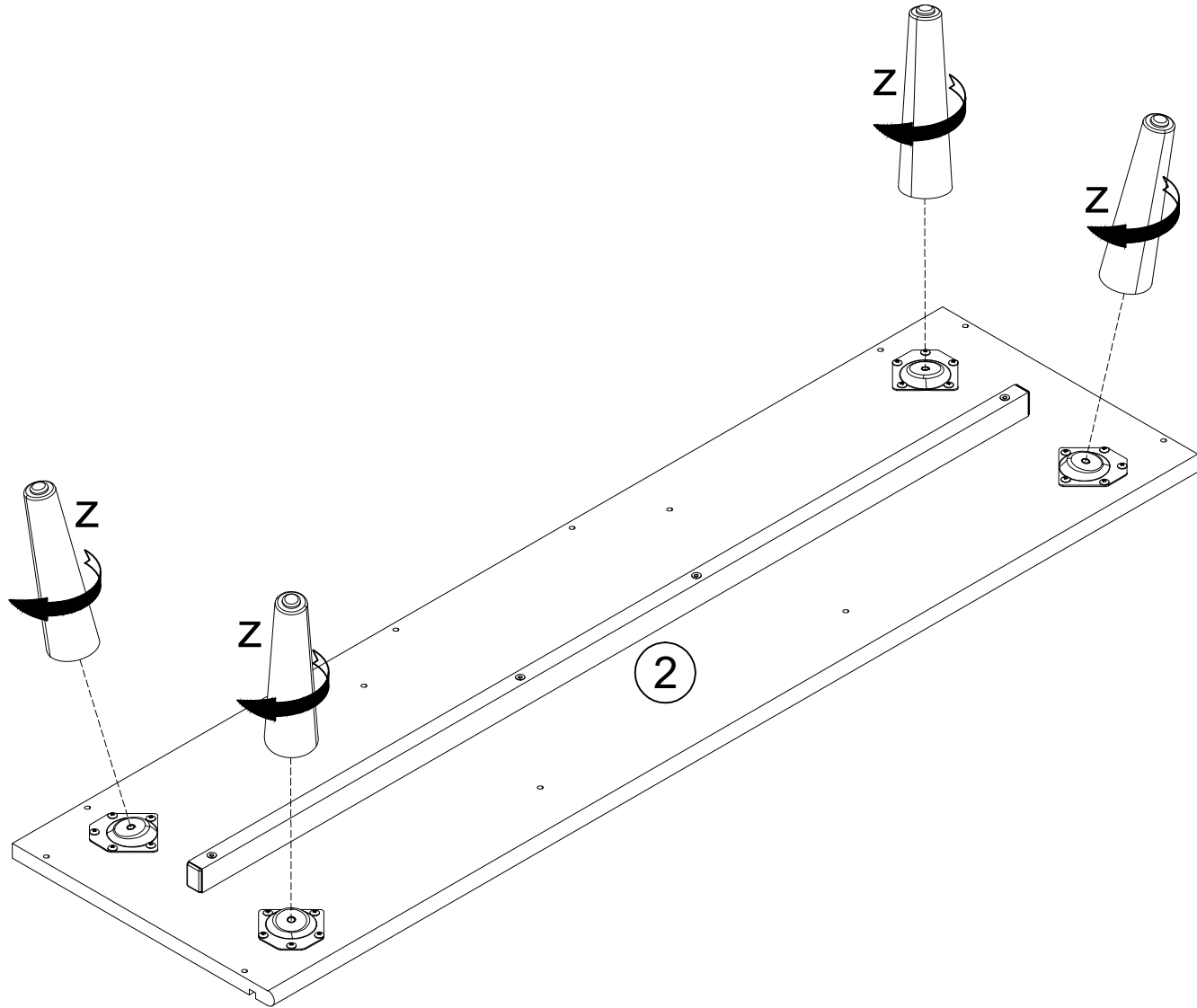

3

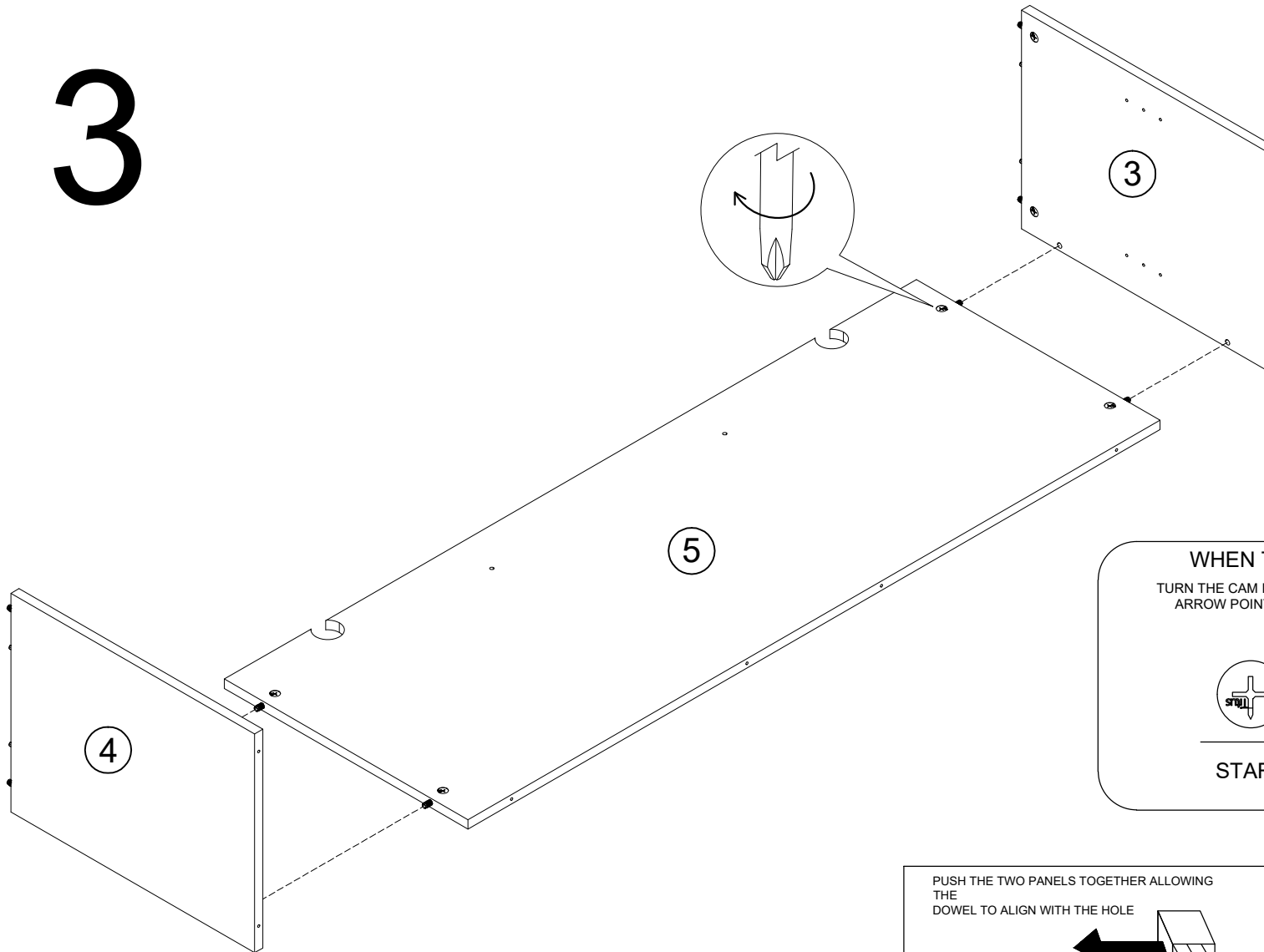

WHEN TIGHTENING THE CAM
TURN THE CAM IN A CLOCKWISE DIRECTION UNTIL THE
ARROW POINTS IN THE POSITIONS SHOWN IN THE
DIAGRAMS BELOW

START MAXIMUM LOCK

PUSH THE TWO PANELS TOGETHER ALLOWING THE DOWEL TO ALIGN WITH THE HOLE

TURN THE CAM IN A CLOCKWISE DIRECTION

4

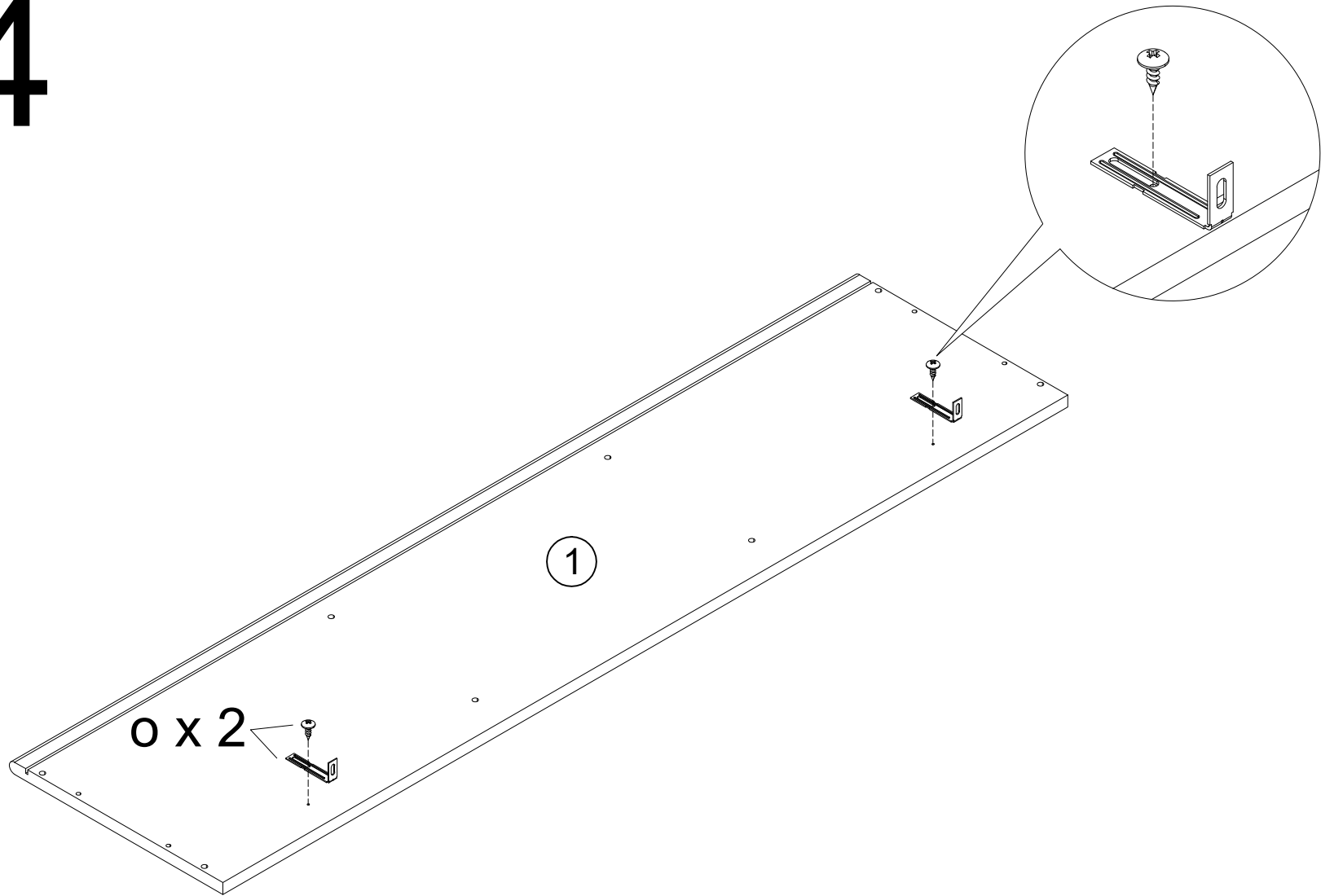

5

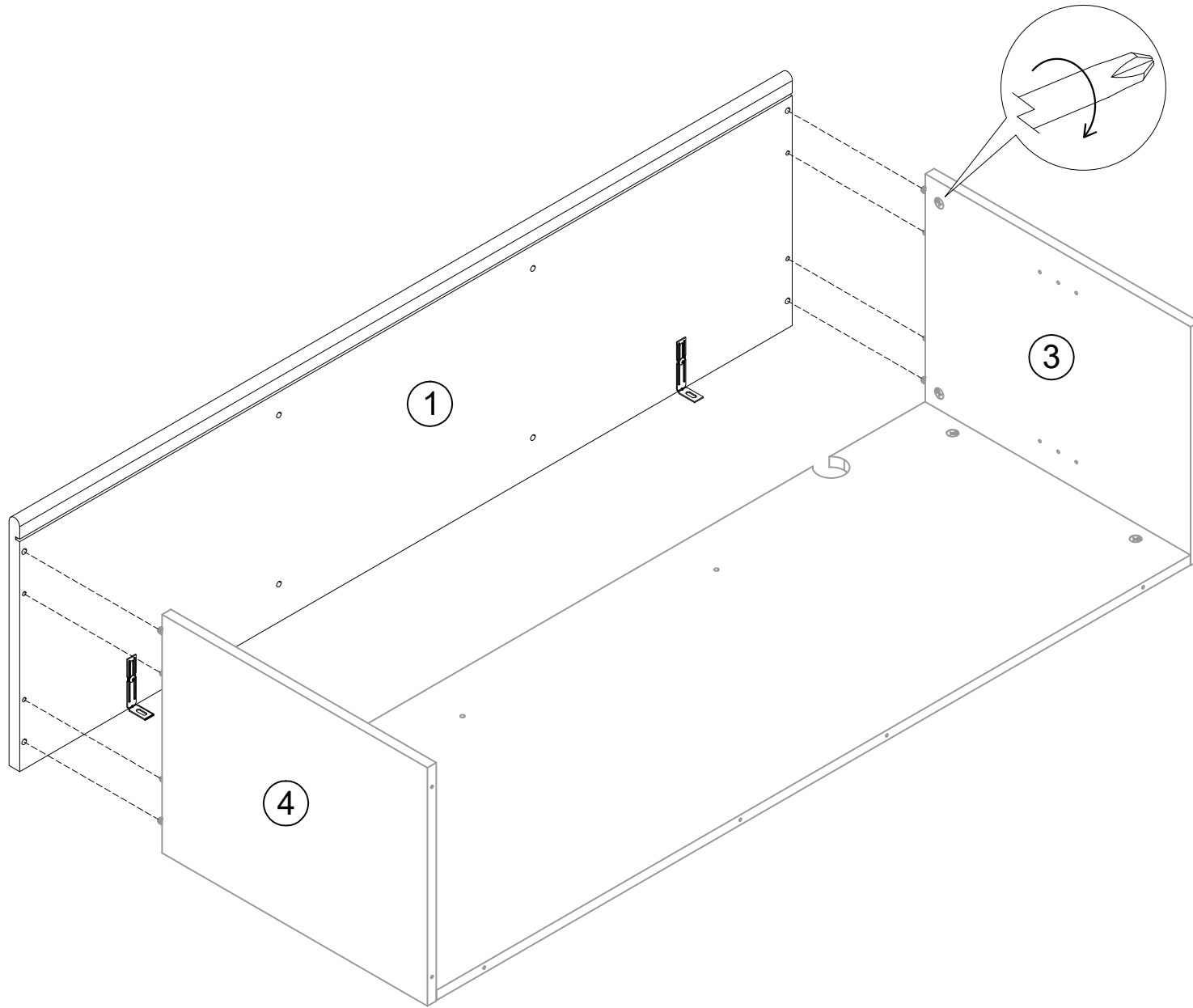

6

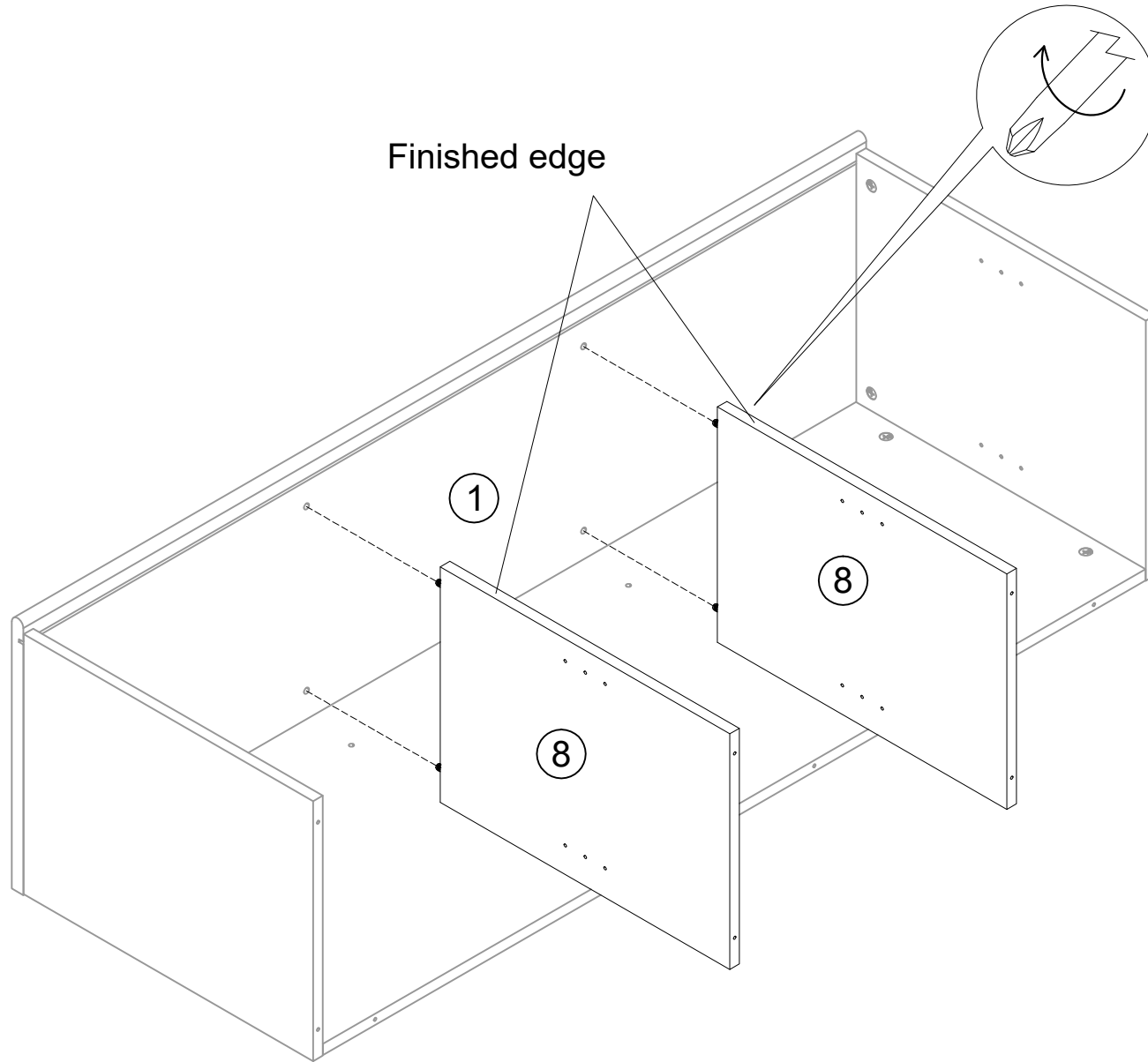

7

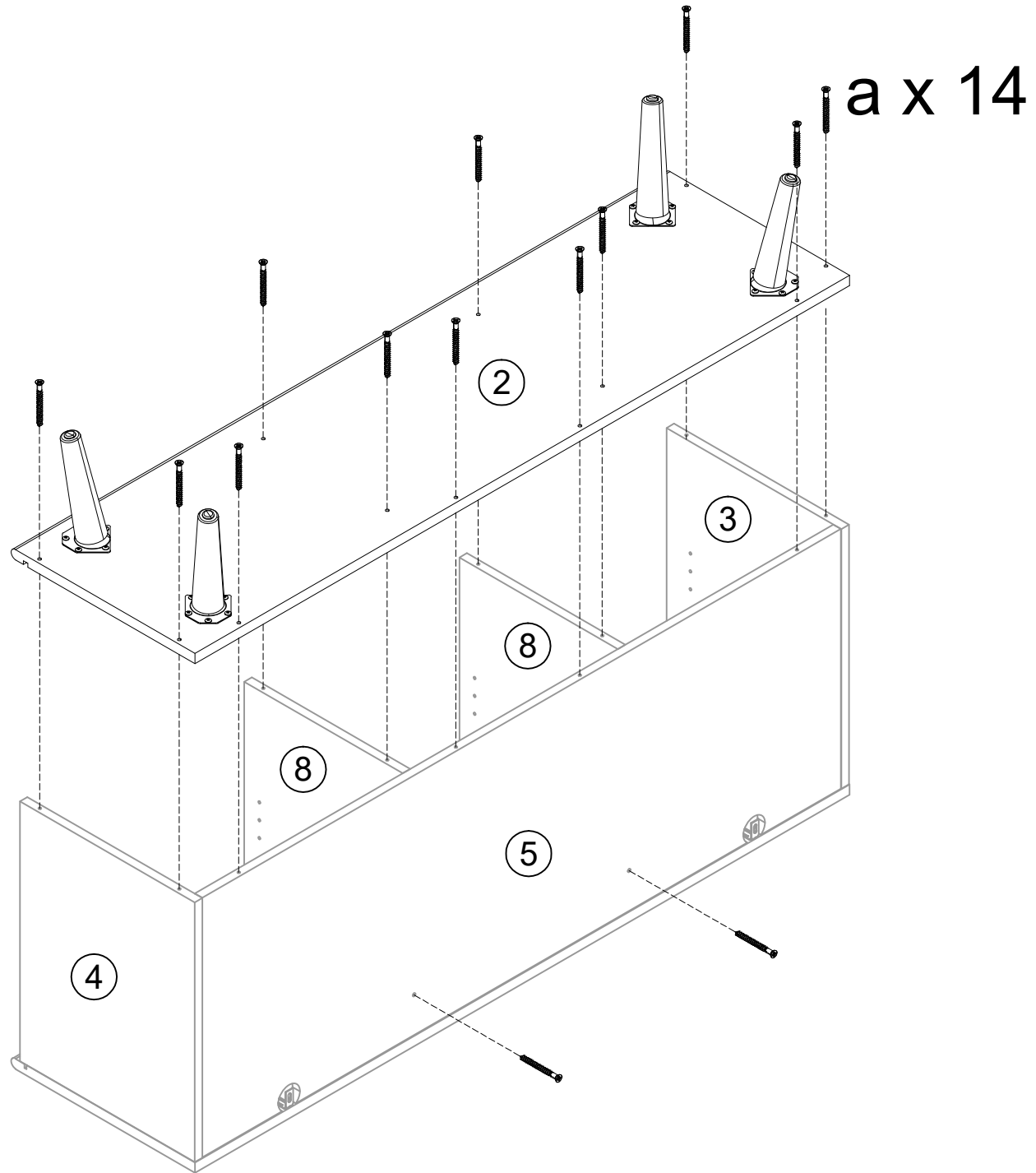

8

We recommend the use of the wall attachment bracket/strap provided for safety reasons.
Secure the other end of the strap to the wall with an appropriate screw and wall plug for your wall type (not provided).

Warning: Always ensure intended wall area to be drilled is free from hidden electrical wire, water, and gas pipes , If in doubt please consult a qualified trades person.

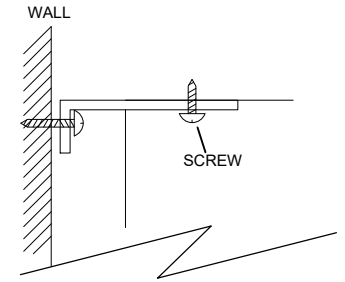
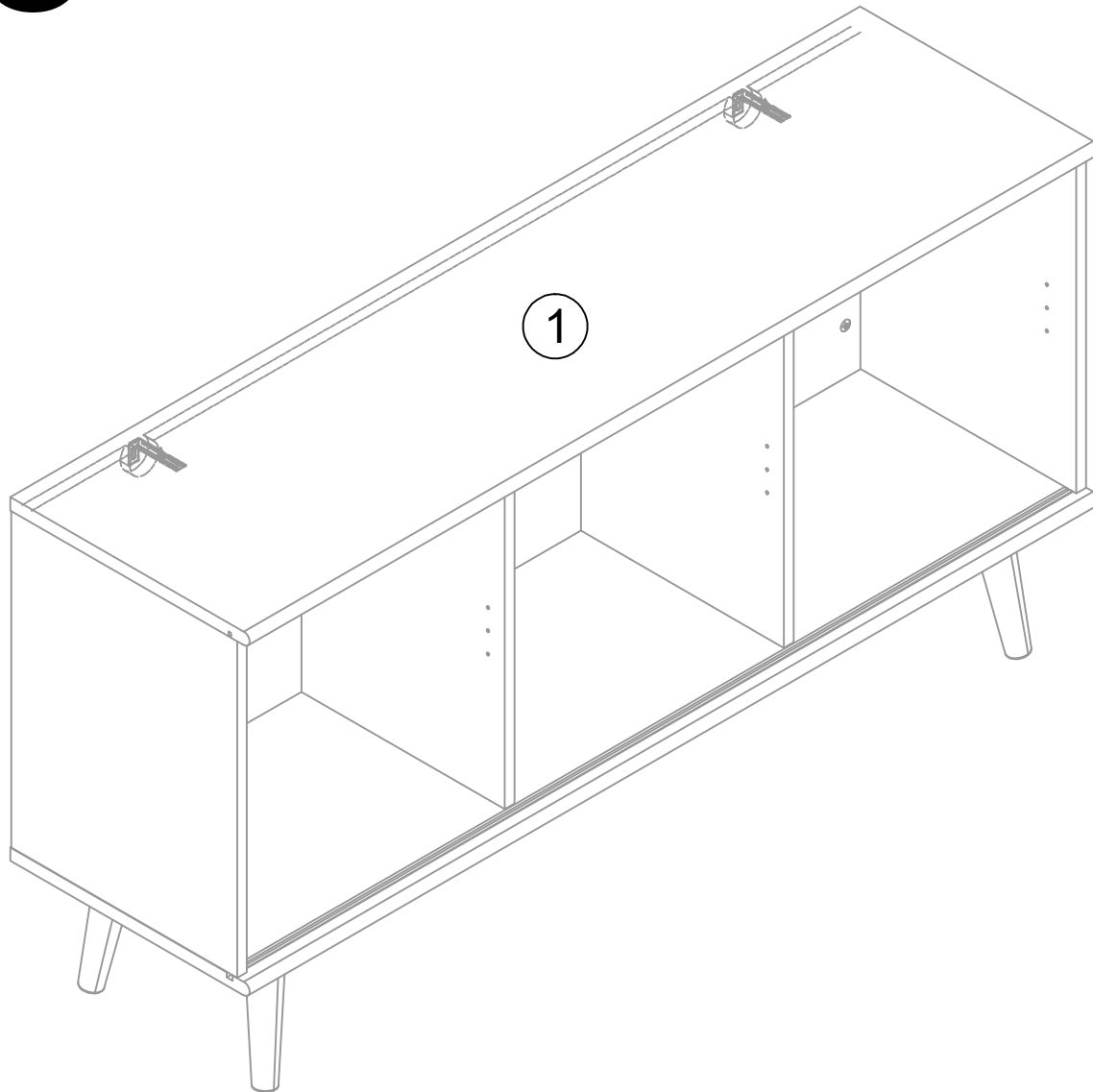

9

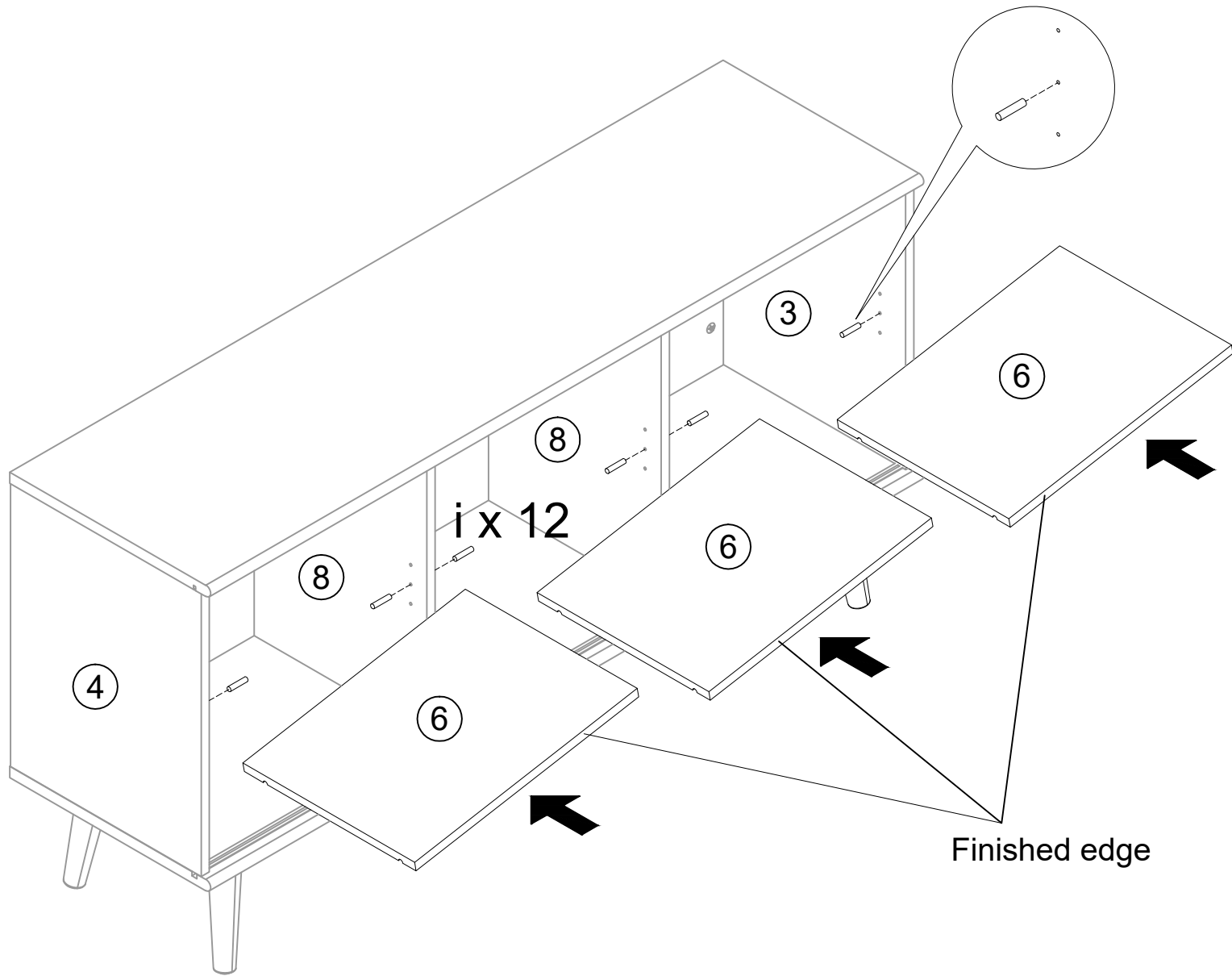

10

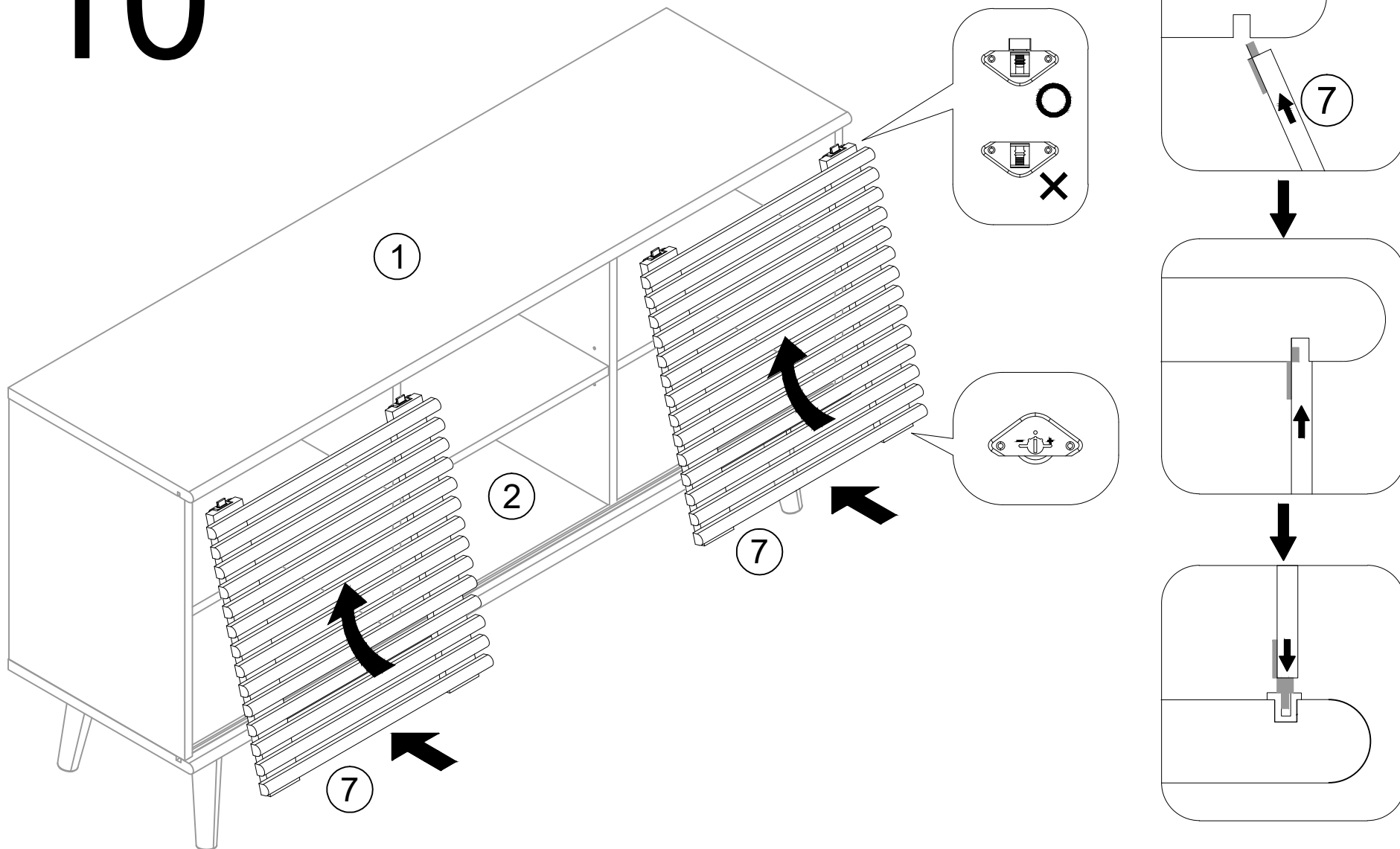

11



FR:12mois
NL:12Maanden
DE:12Monate
ES:12Meses

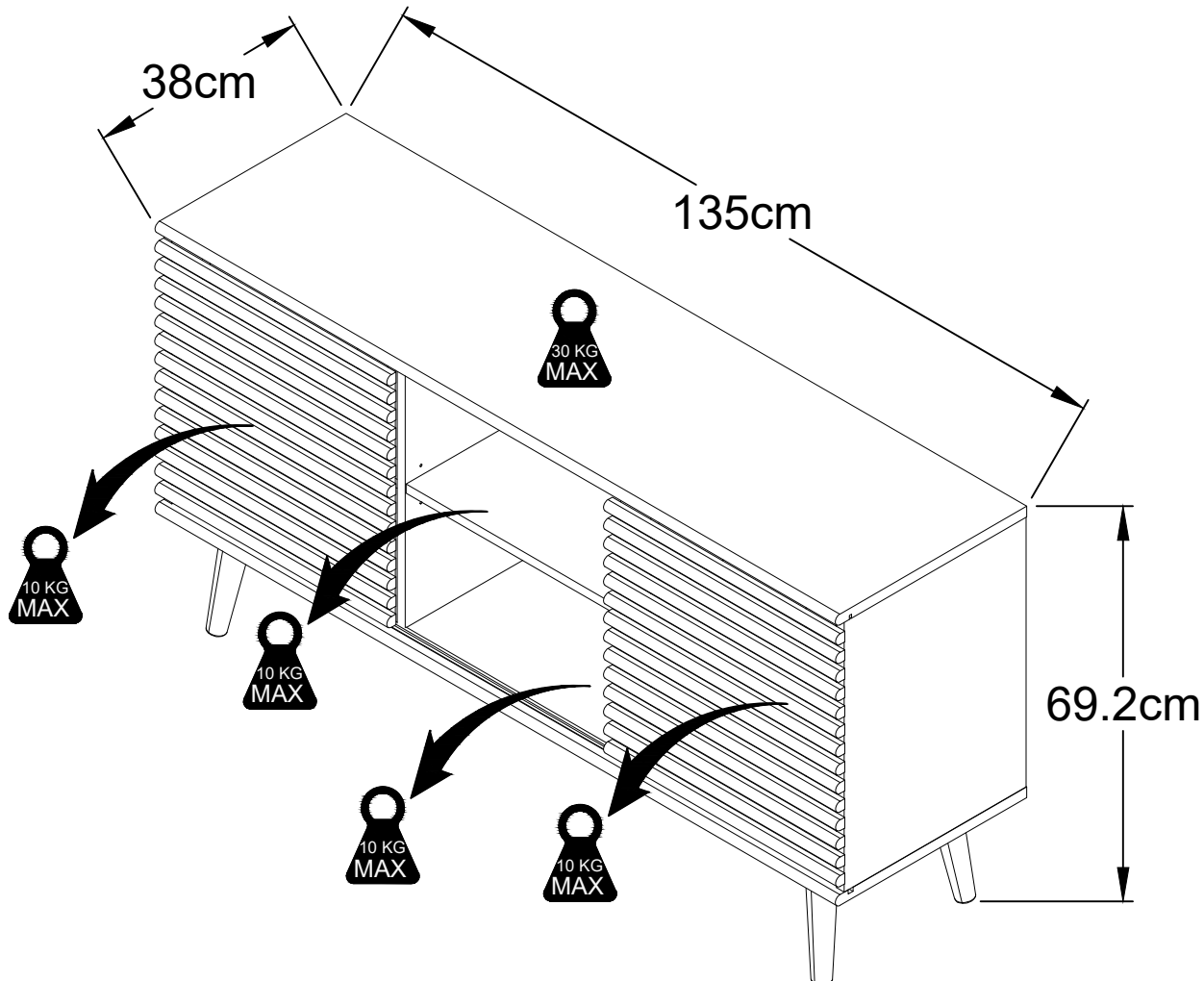
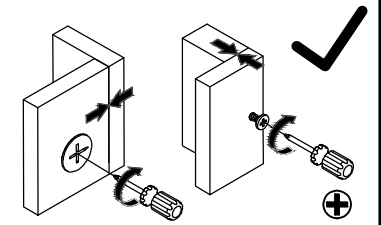

GB

- ° A safety strap / bracket is included with this item. Please ensure the strap / bracket is attached to the product and the wall to ensure it remains stable at all times during use.
- ° The unit must only be used on a level floor.

FR

- ° Une sangle / un support de sécurité est inclus dans cet article. Assurez-vous que la sangle / le support soit fixé au produit et au mur pour s'assurer qu'il reste stable en permanence pendant l'utilisation.
- ° Le produit doit être utilisé à hauteur de plancher.

NL

- ° Dit product is inclusief veiligheids riempje / haakje. Zorg ervoor dat het riempje / haakje aan het product en de muur bevestigd wordt zodat het stabiel blijft bij gebruik.
- ° Dit meubel dient alleen op een even vloer gebruikt te worden.

DE

- ° Dieses Produkt enthält einen Sicherheitsriemen mit Schlaufe. Der Riemen und die Schlaufe müssen am Produkt und der Wand befestigt werden, damit das Produkt immer stabil steht.
- ° Stellen Sie das Produkt nur auf einem ebenen Untergrund auf.

ES

- ° Incluye una cinta / soporte de seguridad. Asegúrate de que la cinta / soporte esté adherida al producto y a la pared para garantizar que permanezca estable en todo momento durante su uso.
- ° El producto solo debe usarse en un suelo nivelado.