

MADE[⊕]

DAMIEN

Damien Two-door wardrobe

Damien Armoire à deux portes

Damien Tweedeurskast

Damien Kleiderschrank

Armario de dos puertas Damien



GB Recommendations for the continual safe use of this product are stated on the final page of these instructions.

Please retain for future reference.

FR Les conseils d'utilisation de ce produit sont indiqués sur la dernière page de ces instructions.

Veillez les conserver pour vous y référer si besoin.

NL Aanwijzingen voor veilig gebruik van dit meubel worden toegelicht op de laatste pagina van deze instructies.

Bewaar deze folder goed.

DE Auf der letzten Seite dieser Anleitung findest du Hinweise für eine langfristig sichere Anwendung dieses Produktes.

Bitte bewahre sie gut auf.

ES Las recomendaciones para el uso continuado de este producto figuran en la última página de estas instrucciones.

Por favor, consévalas para futuras consultas.

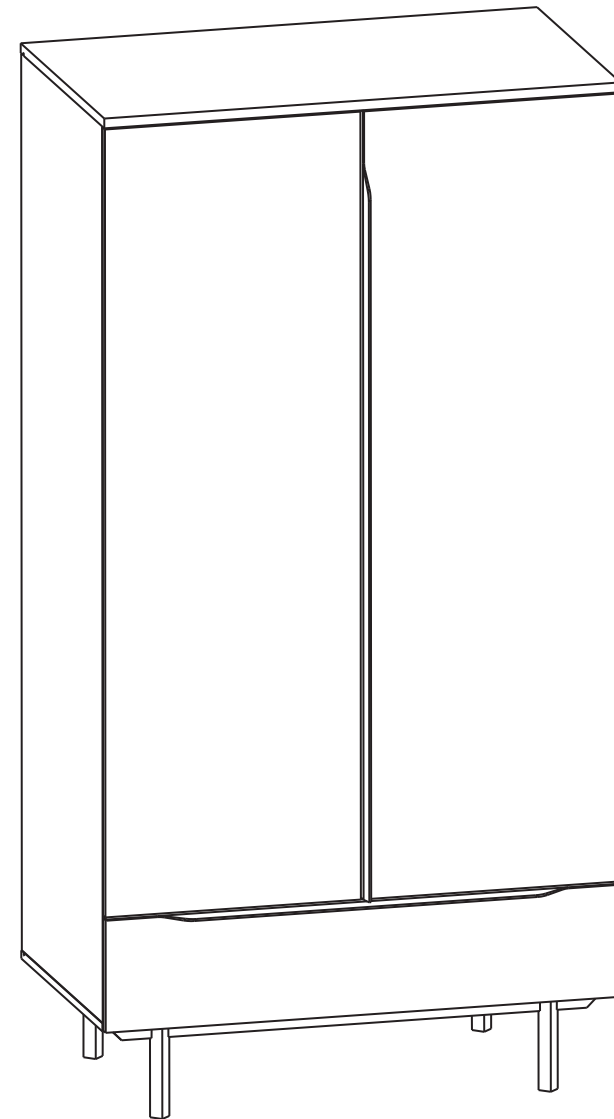



"Assembly to be carried out by a competent adult only."

"During assembly children should be kept away from the product due to possible risk of injury"

"Do not use this item if any components are missing or damaged."

"Any additional or replacement parts should be obtained from the manufacturer or distributor"



SAFETY DISCLAIMER

ENGLISH

Because of the variety of different wall types, we cannot provide you with the exact fittings to fix this product. It is necessary that you identify the type of wall you intend to fix this item onto and contact your local hardware store to get the appropriate fittings.

FRANÇAIS

A cause des différentes variétés de mur, nous ne pouvons pas vous fournir les exacts ustensiles pour fixer ce produit. Il est nécessaire que vous identifiez sur quel type de mur vous entendez fixer ces accessoires, et vous contactiez le fournisseur de matériaux le plus proche pour vous procurez les ustensiles les plus appropriés.

NEDERLANDS

Vanwege het grote aantal verschillende muurtypen, kunnen we je geen exacte instructies geven voor het monteren van deze haken. Bij twijfel kun je het beste nakijken tegen welk type ondergrond je de haken wil bevestigen en vervolgens navraag doen bij een bouwmarkt bij jou in de buurt.

DEUTSCH

Aufgrund der vielen Arten von Wänden, können wir Ihnen leider nicht die richtigen Zubehörteile für dieses Produkt liefern. Finden Sie heraus, was Sie für eine Wand haben und fragen Sie im Baumarkt nach den entsprechenden Armaturen, um es anzubringen.

ESPAÑOL

Debido a la variedad de las diferentes paredes no podemos proporcionarle los servicios de accesorios exactos para fijar este producto. Es necesario que identifique el tipo de pared en la que desea fijar este elemento y póngase en contacto con su ferretería local para obtener los accesorios adecuados.

🕒 180 min

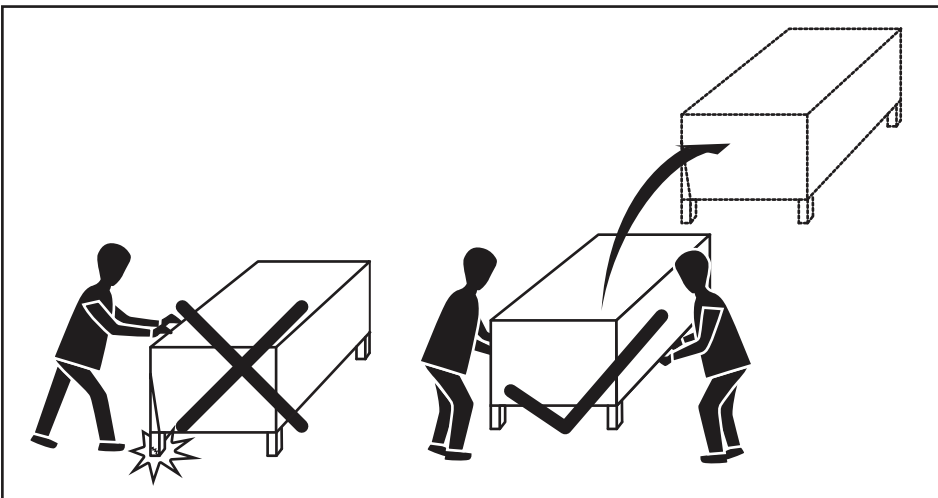
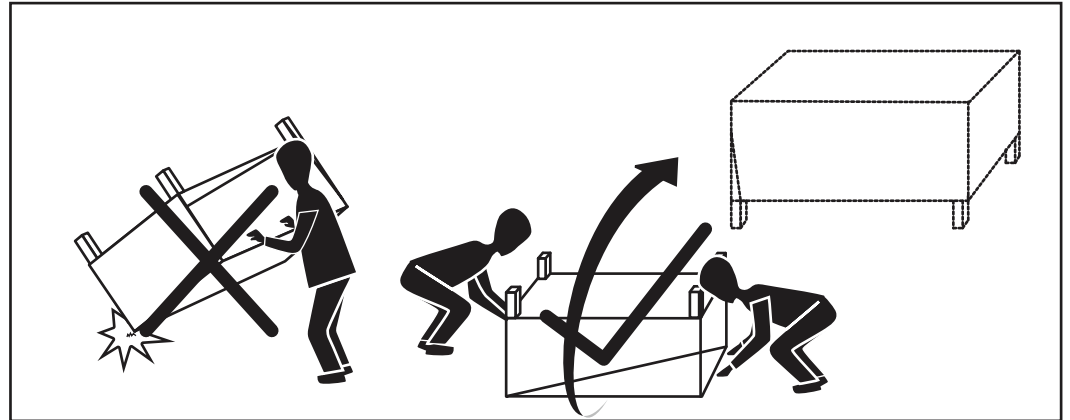
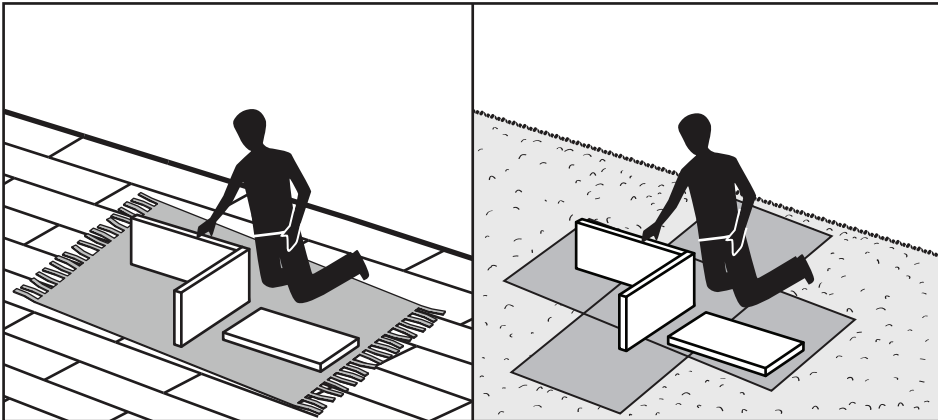
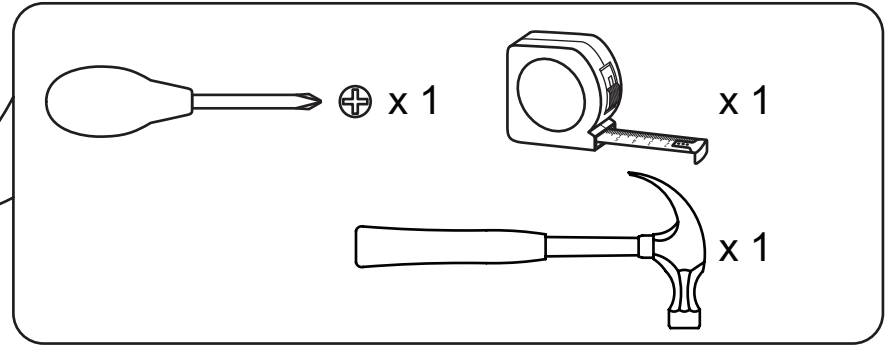
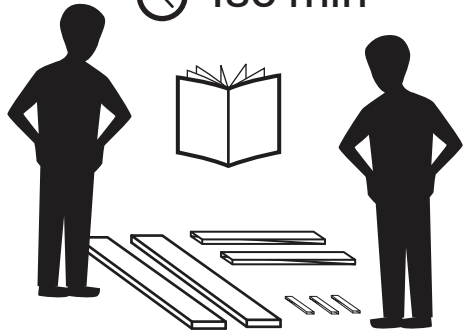



1

B1  x12
f 8x28

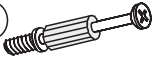
M1  x8
f15x12mm

T1  x8
5x39mm

K1  x4
Ø7x50mm

J23  x22

P2  x4
3x20

G10  x8

A13  x8
M6x20

W1  x2

C14  x4
f20mm

2

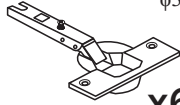
Y0  x6
Kr0 $\phi 35$

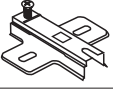
D6  x6
H2

E3  x12
6,3x13

S8  x12
4x13

3

M2  x2
f12x10mm

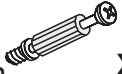
T2  x2
5x35mm

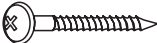
P5  x4
4x30

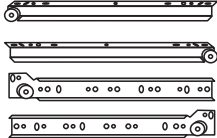
R23  L-400 mm
x1L/1R

E24  x6
6,0x11

P10  x4
3x13

S3  x2
3,5x13

F388  x1
L-388

P10  x2
3x13

4

F7  x2

S12  x2
3,0x13

S3A  x7
3,5x13

5

J44  x2

G22  x4

P13  x2
3,5x13

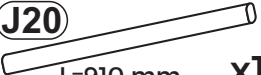
J20  L=910 mm x1

L2  L=1440mm x1

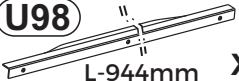
U98  L-944mm x1

U100  L-1442mm x1



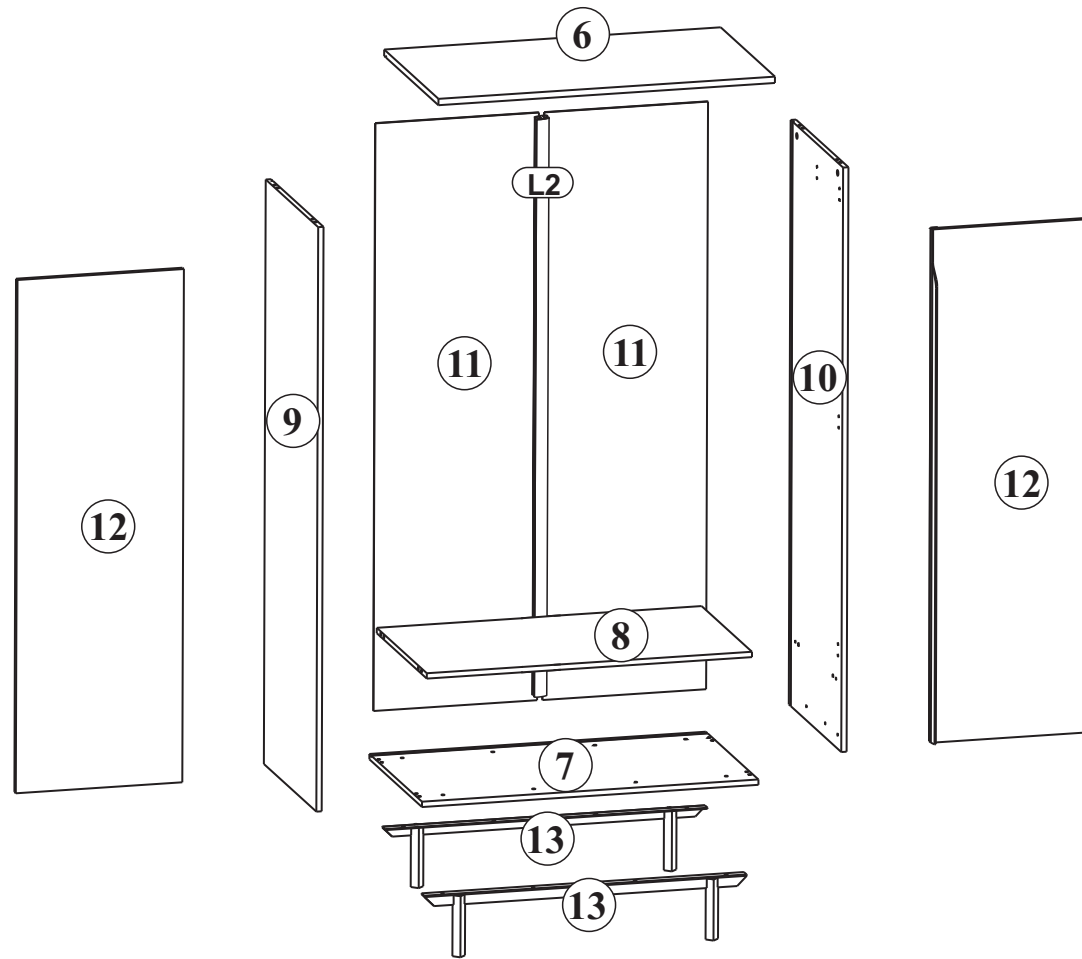

PACK 1/2

**1, 2, 3, 4, 5, 6, 7, 8, 13, J20,
Fittings, Al.**

PACK 2/2

9, 10, 11, 12, L2, U98, U100.

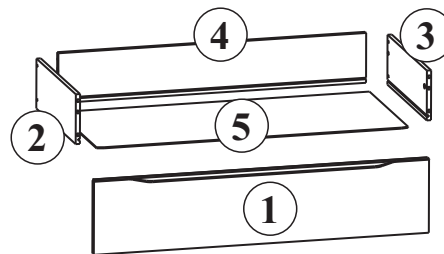

1

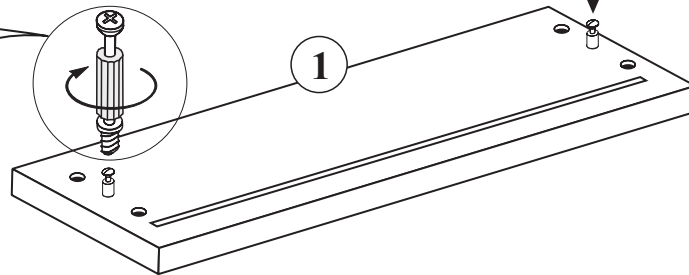
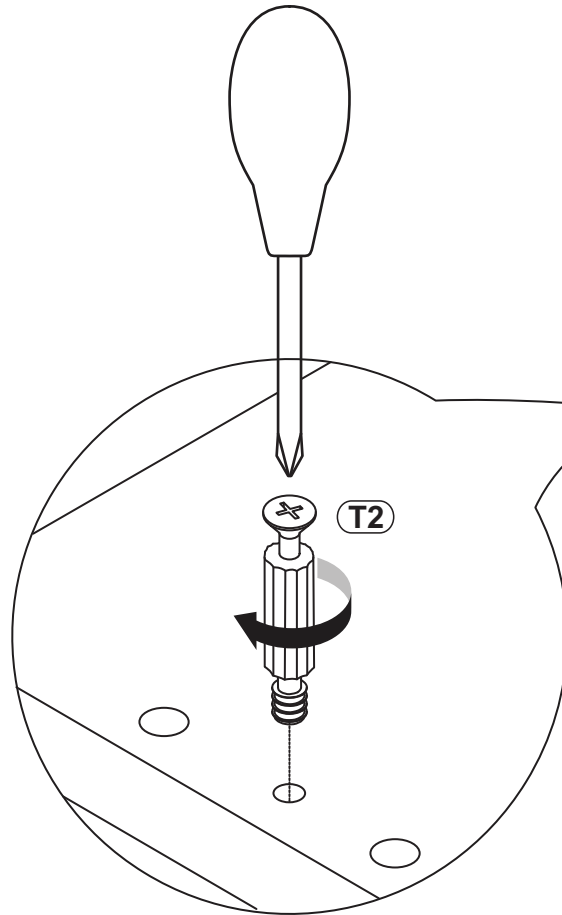
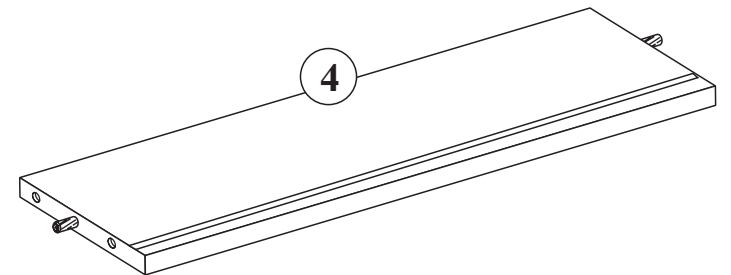
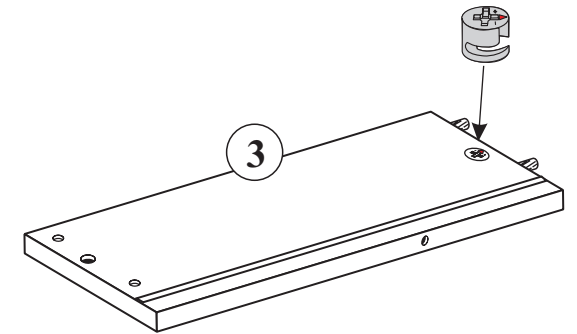
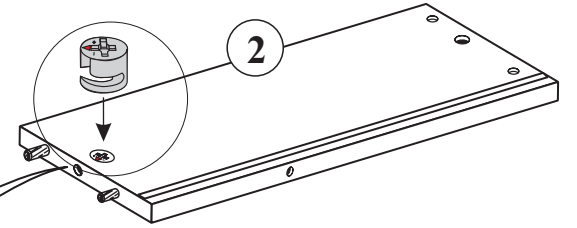
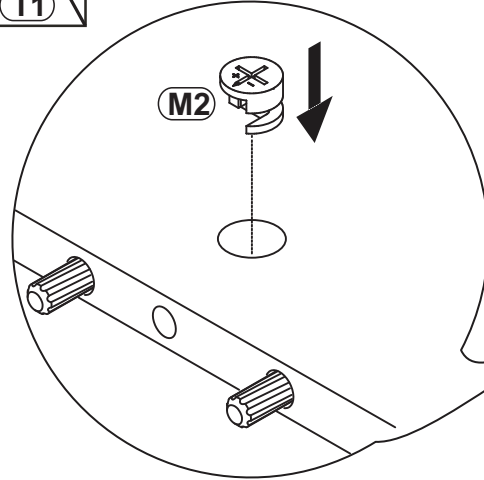
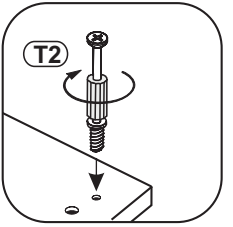
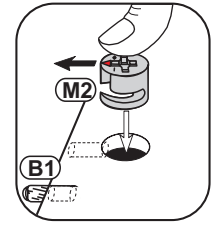
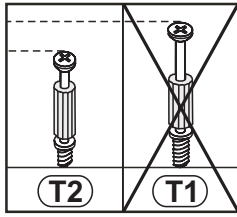
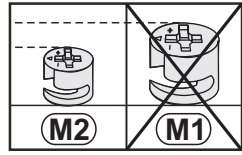

2

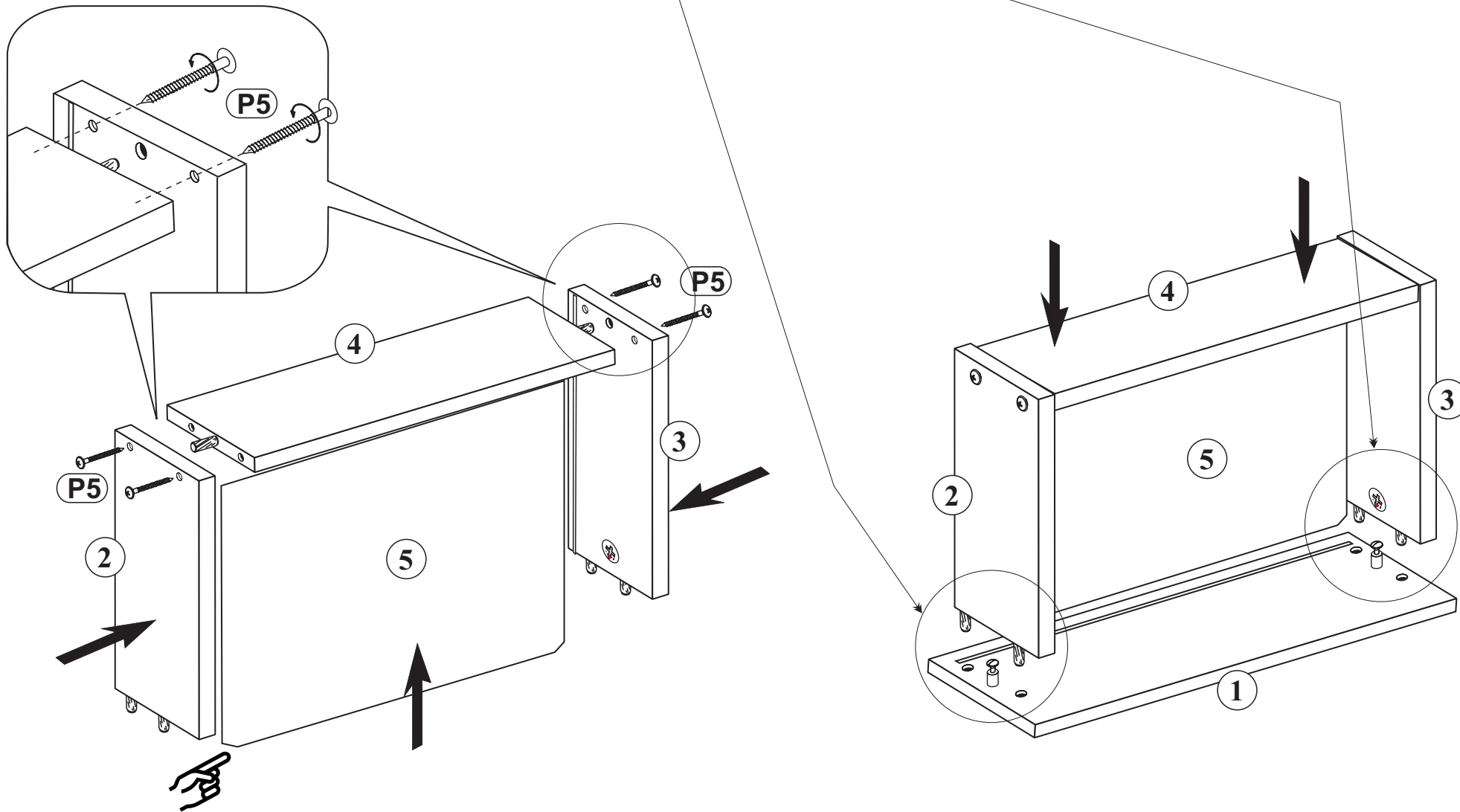
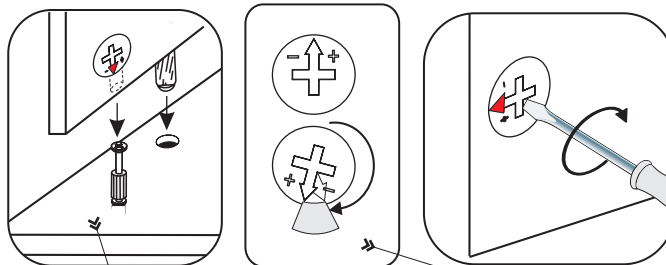

3

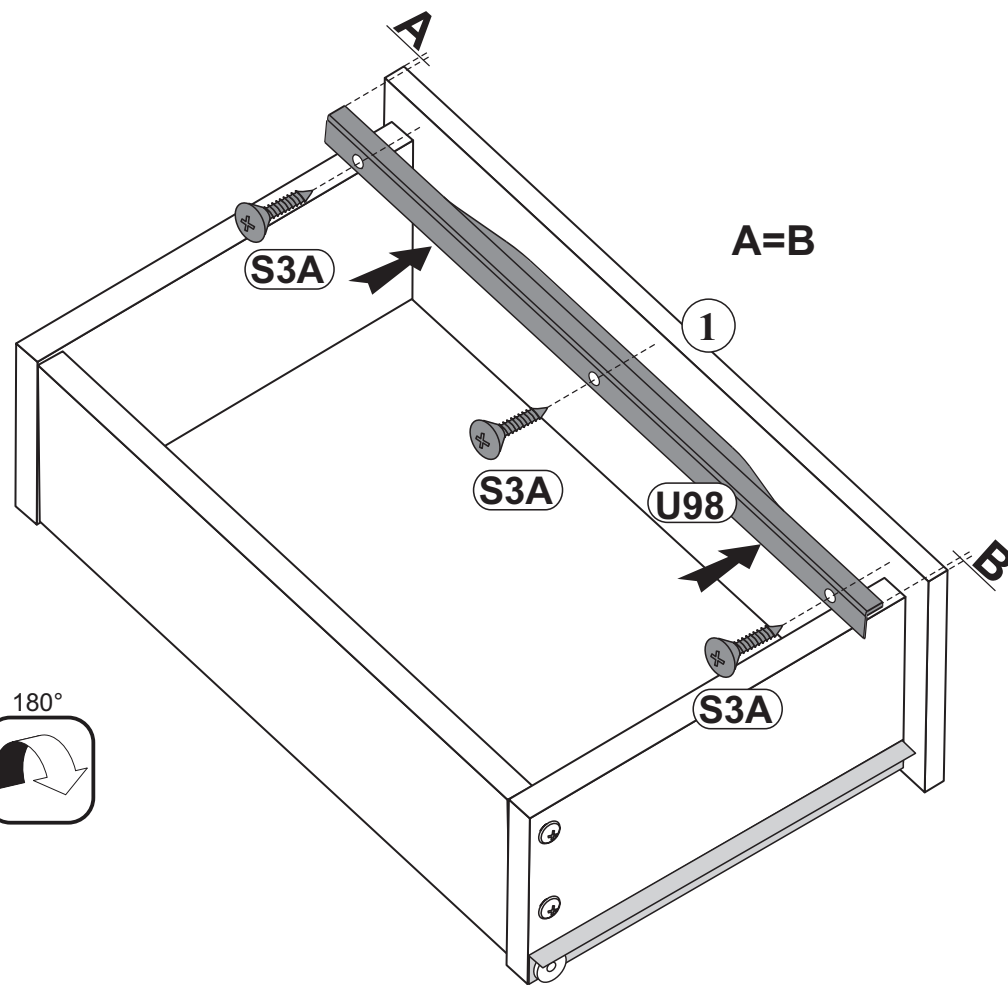
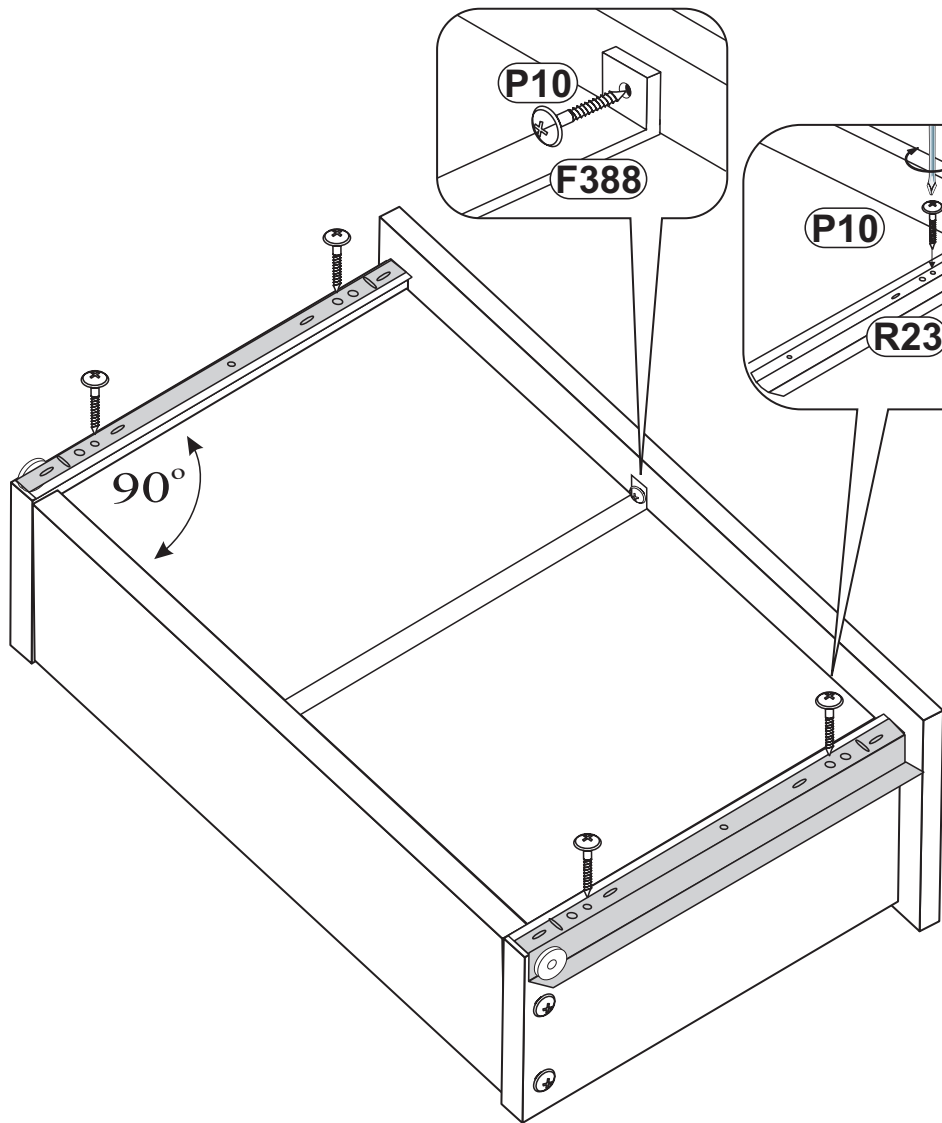

4

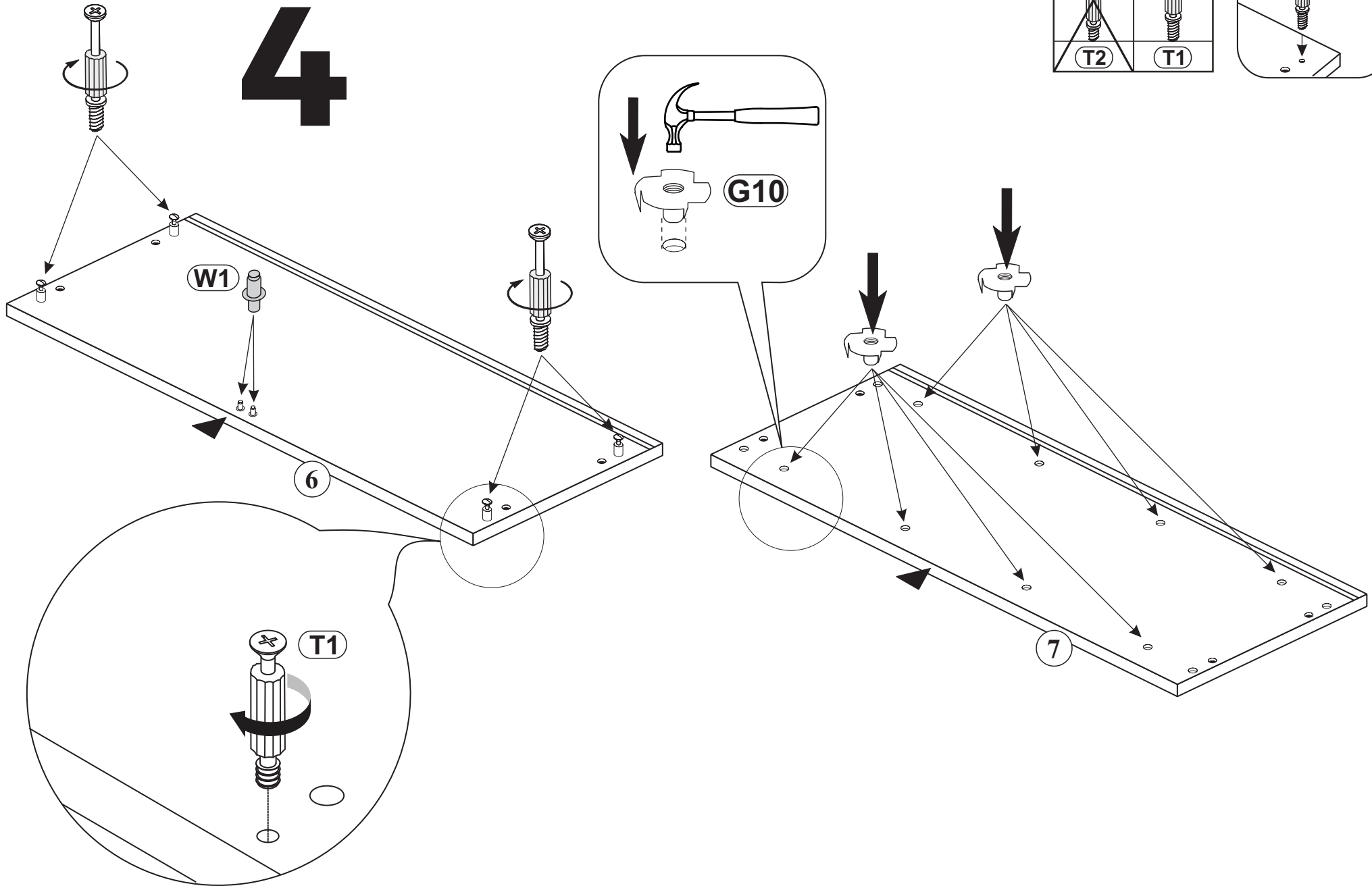

5

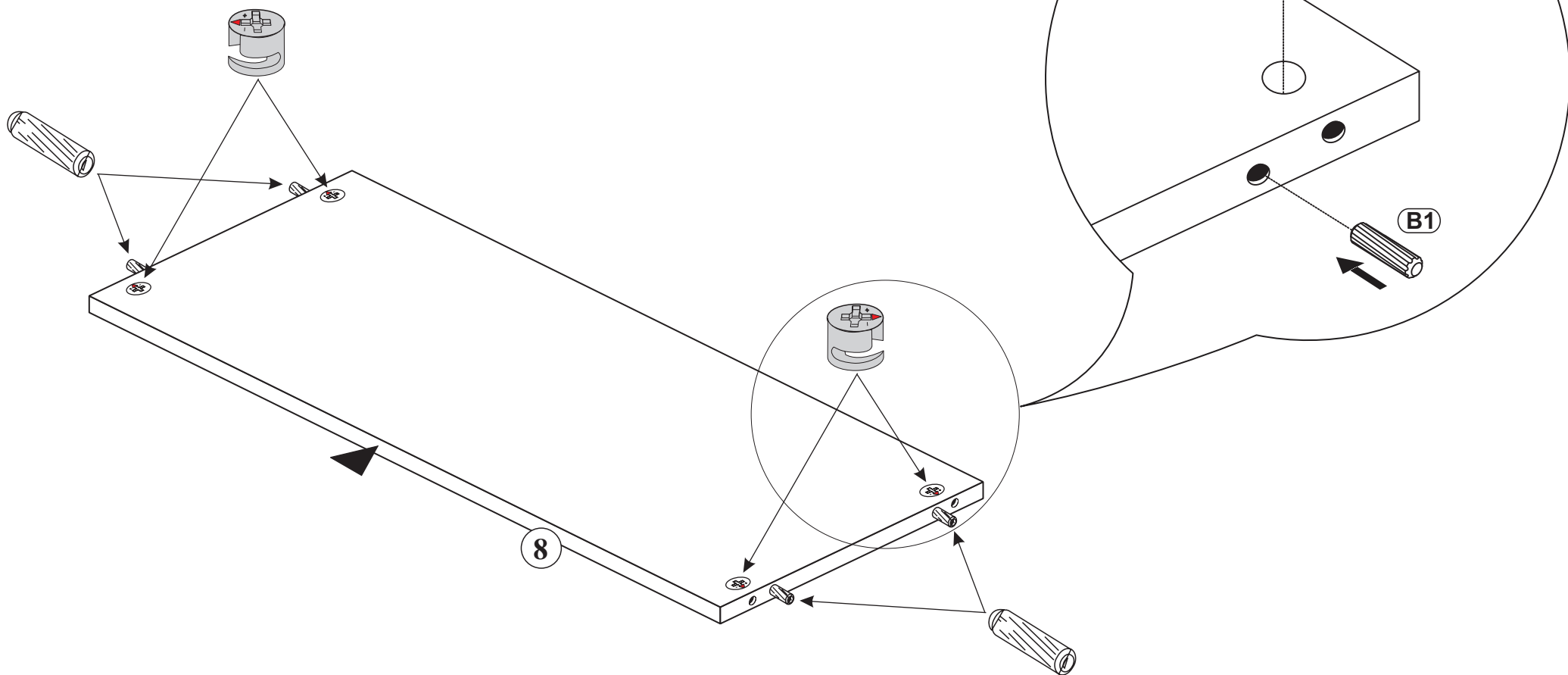
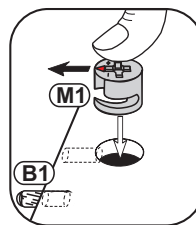
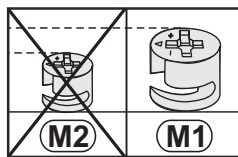

6

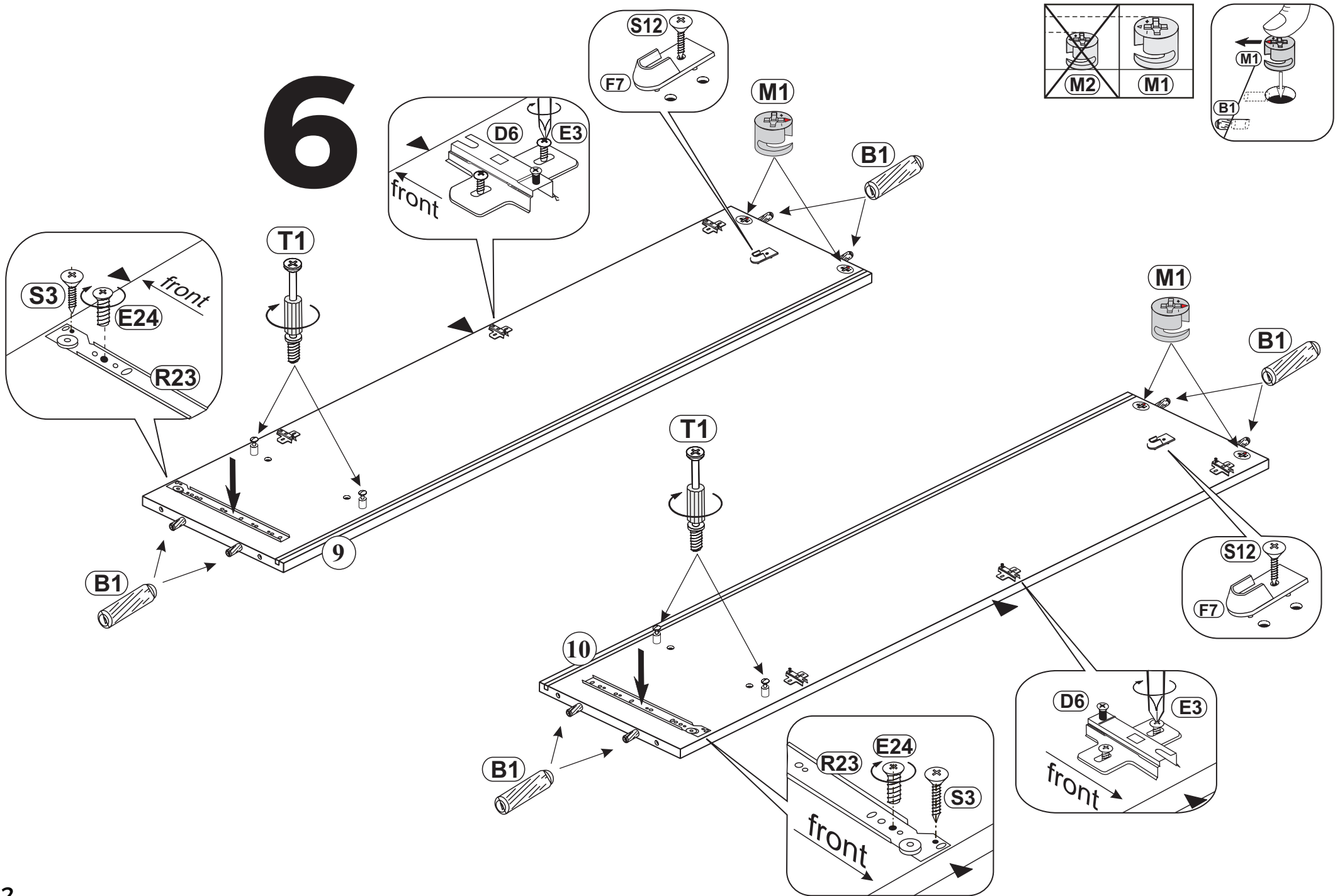

7

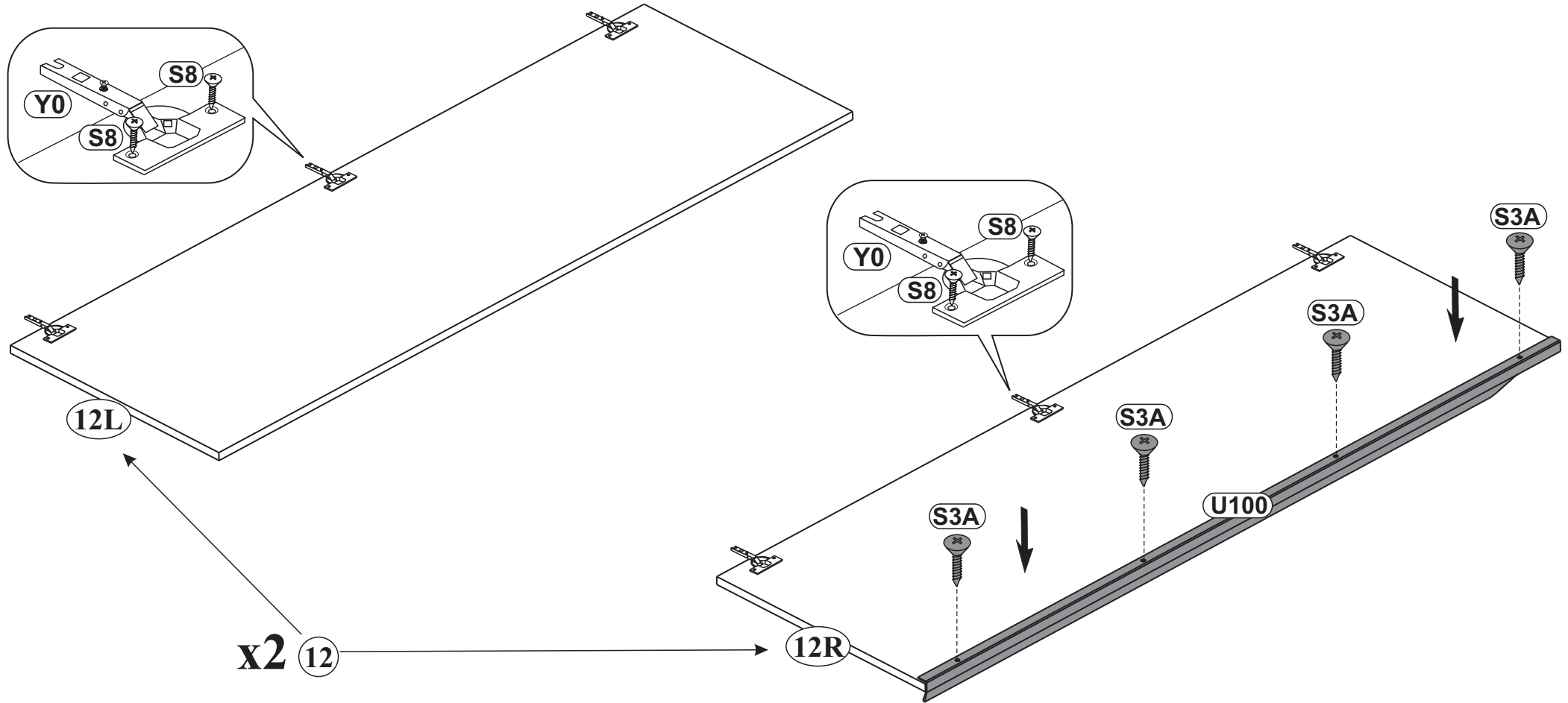

8

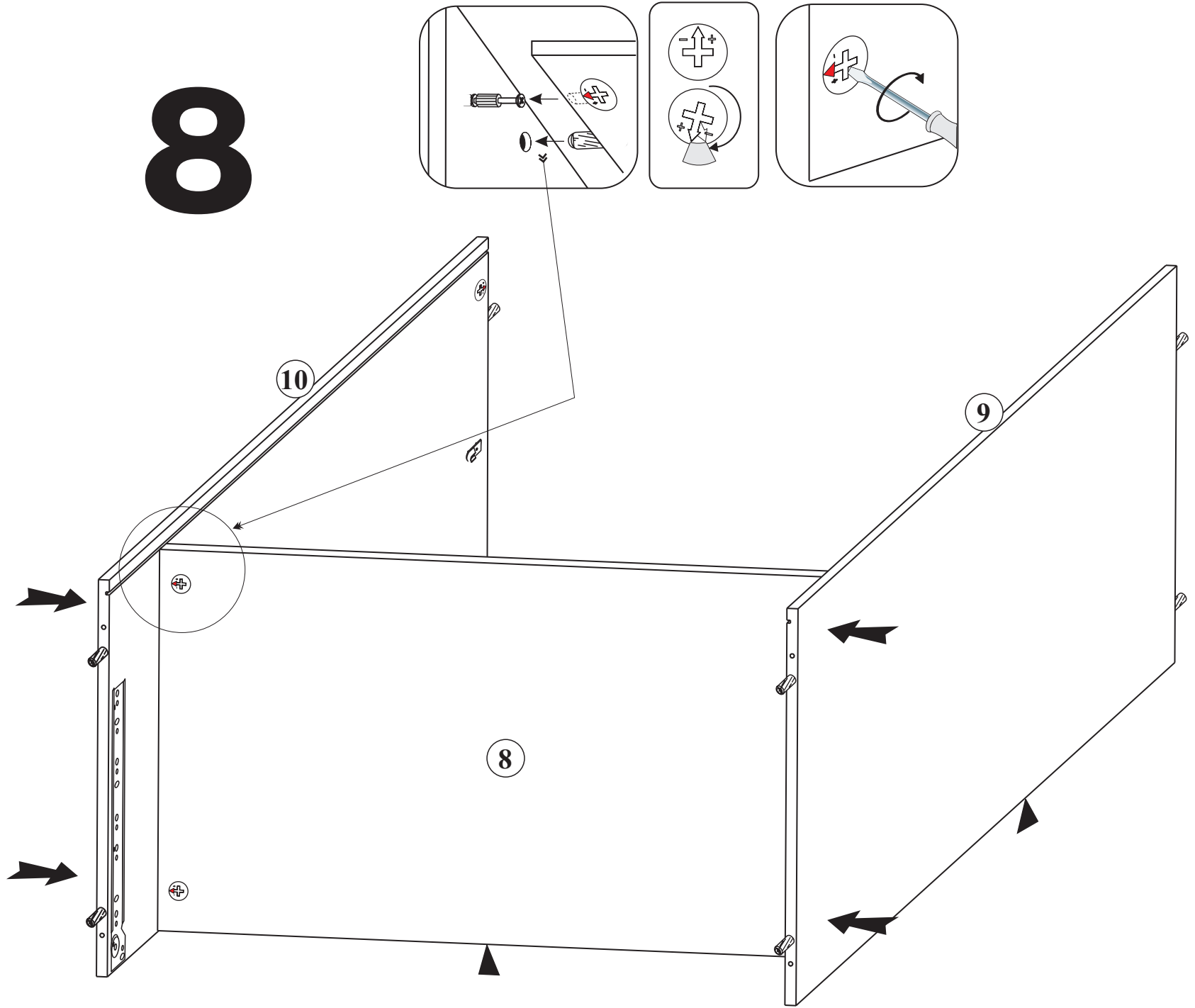

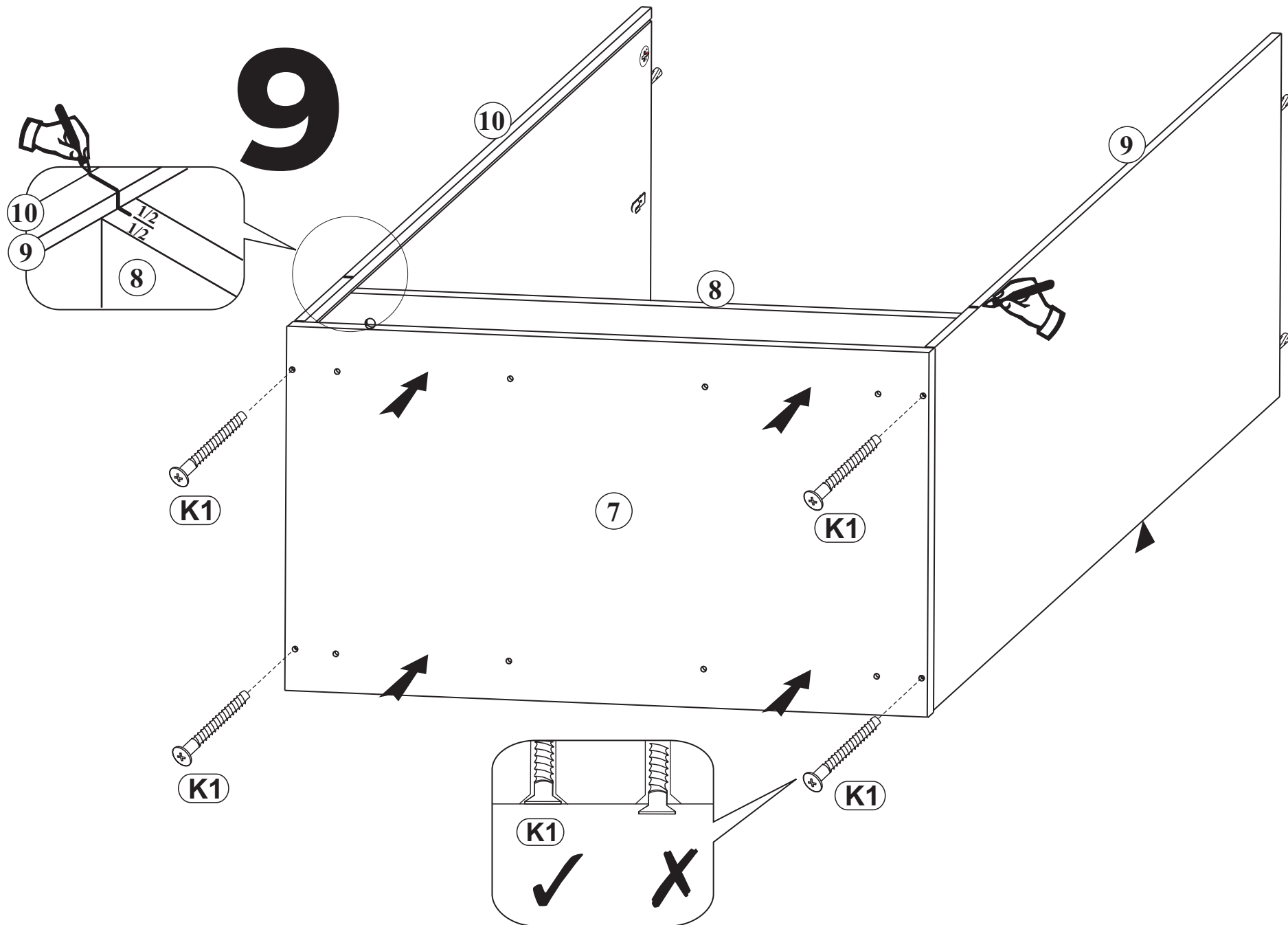

10

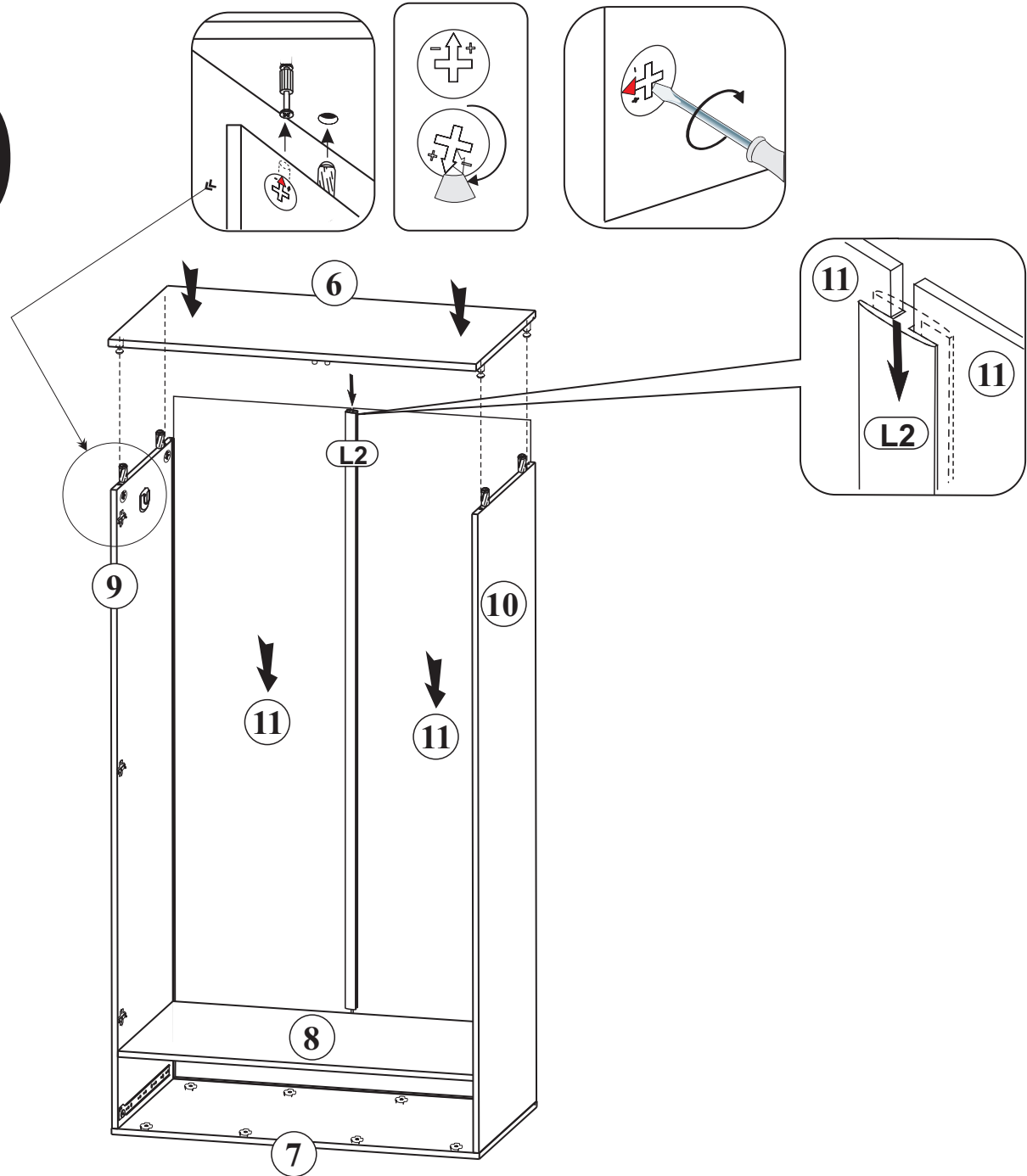

11

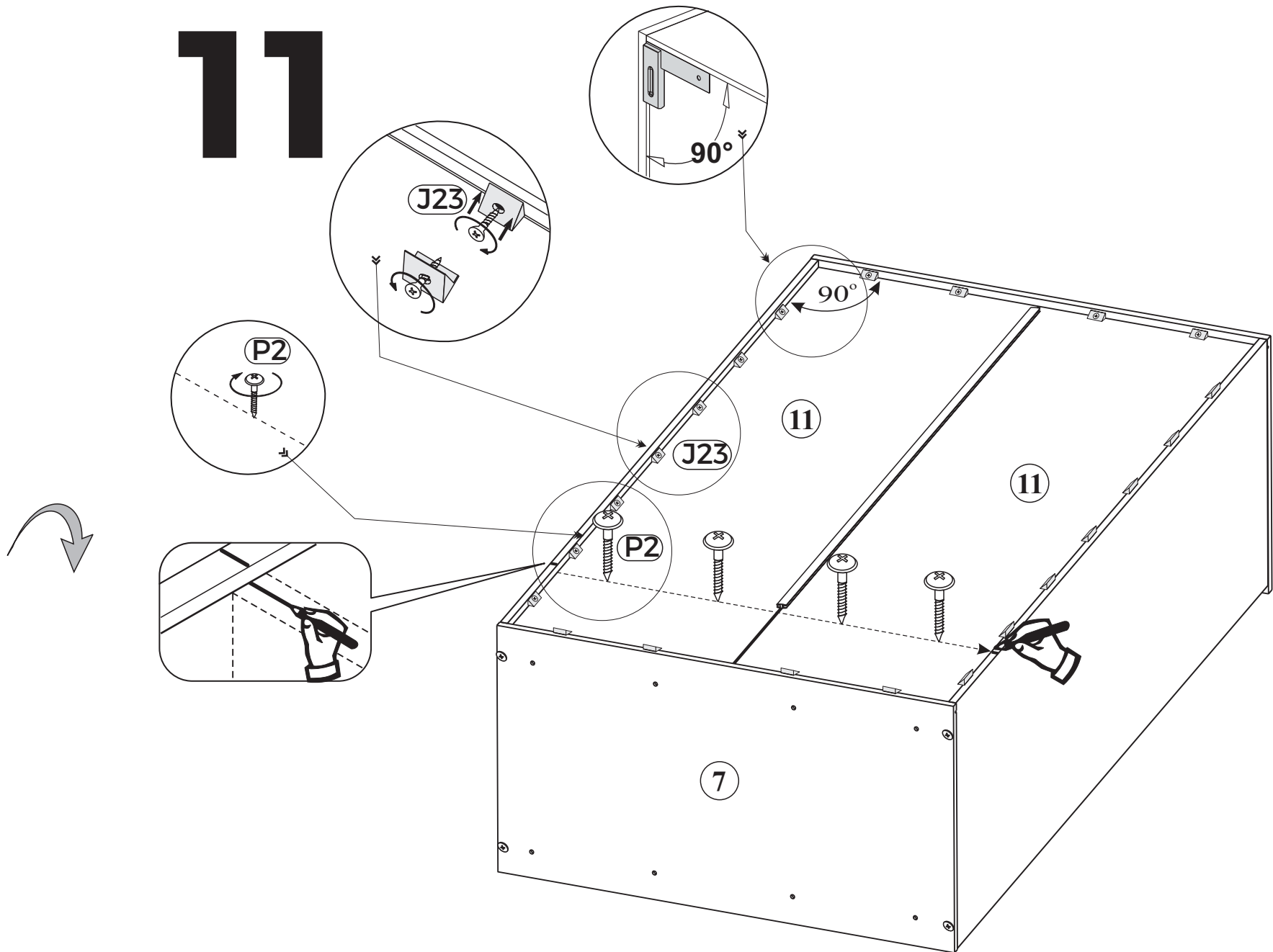

12

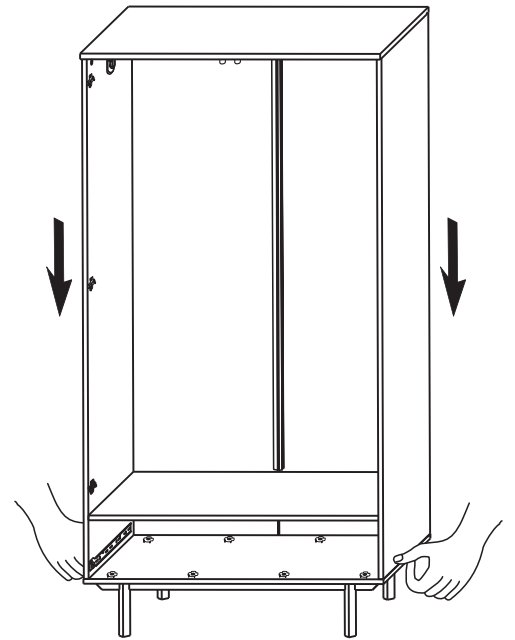
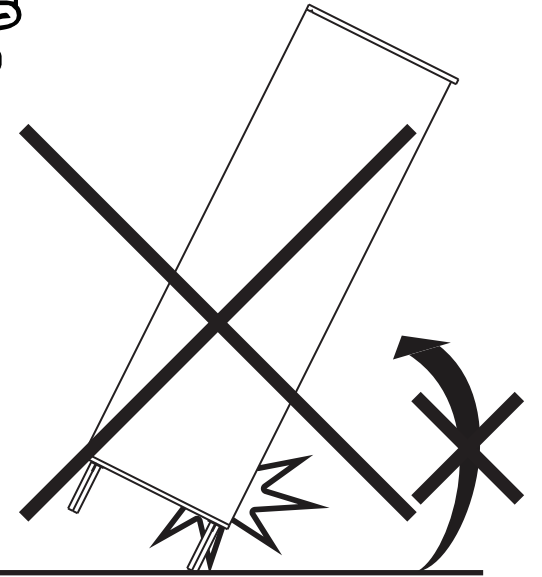
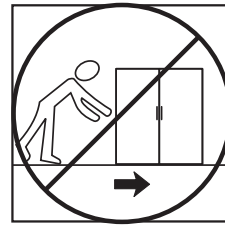
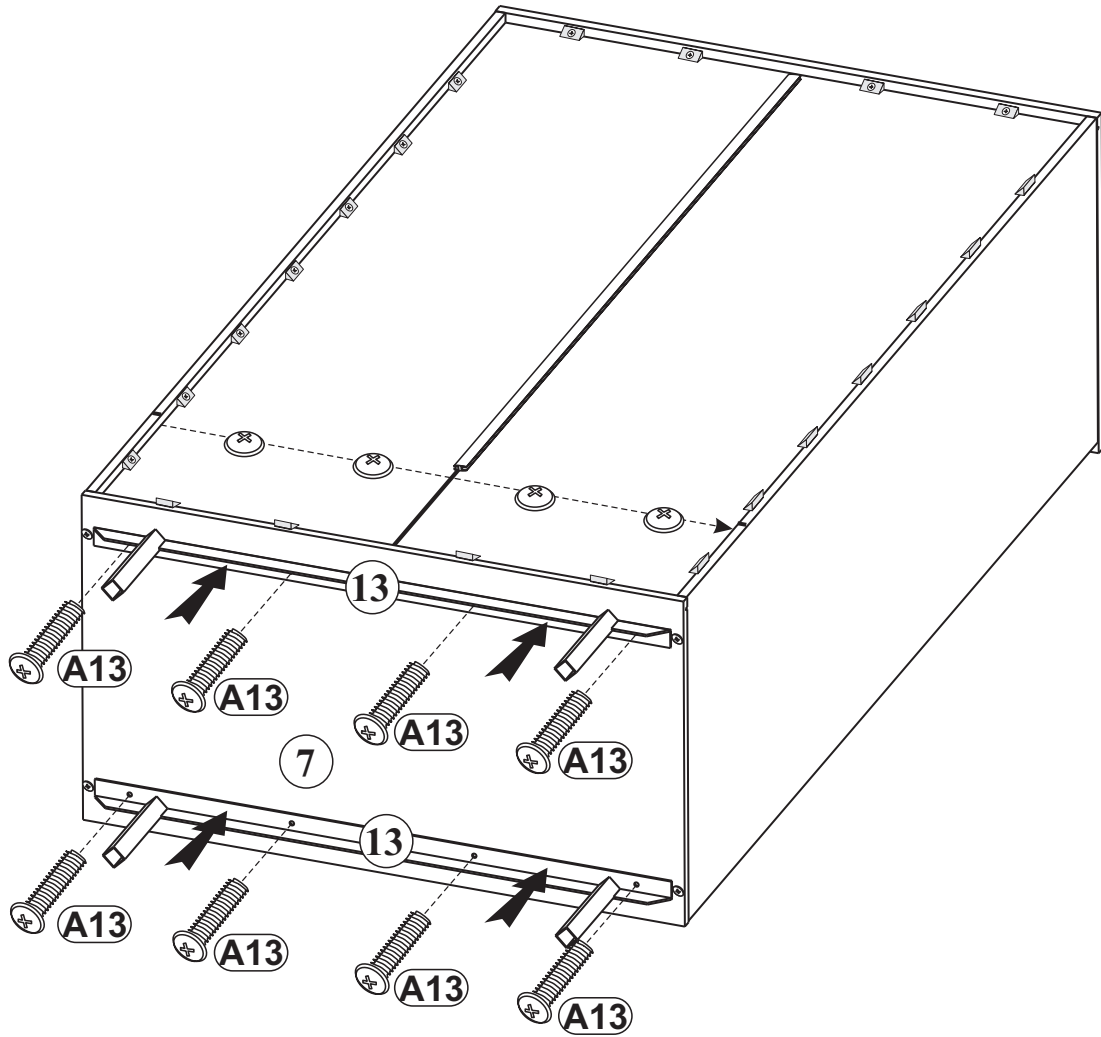

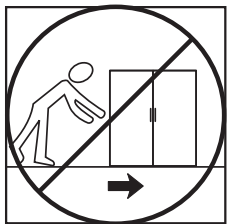

13

GB

- A safety strap / bracket is included with this item. Please ensure the strap / bracket is attached to the product and the wall to ensure it remains stable at all times during use.
- The unit must only be used on a level floor.

FR

- Une sangle / un support de sécurité est inclus dans cet article. Assurez-vous que la sangle/le support soit fixé au produit au mur pour s'assurer qu'il reste stable en permanence pendant l'utilisation.
- Le produit doit être utilisé à hauteur de plancher.

NL

- Dit product is inclusief veiligheids riempje/ haakje. Zorg ervoor dat het riempje / haakje aan het product en de muur bevestigd wordt zodat het stabiel blijft bij gebruik.
- Dit meubel dient allen op een even vloer gebruikt te worden.

DE

- Dieses Produkt enthält einen Sicherheitsriemen mit Schlaufe. Der Riemen und die Schlaufe müssen am Produkt und der Wand befestigt werden, damit das Produkt immer stabil steht.
- Stellen Sie das Produkt nur auf einem ebenen.

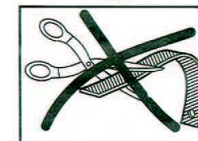
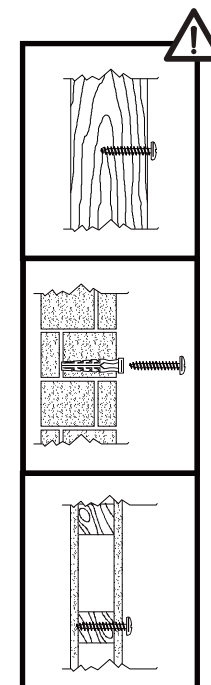
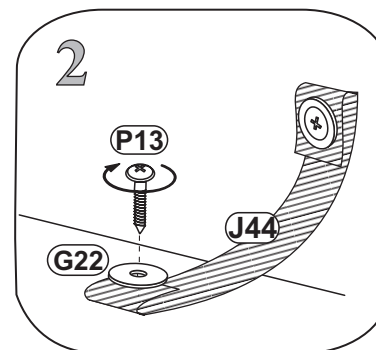
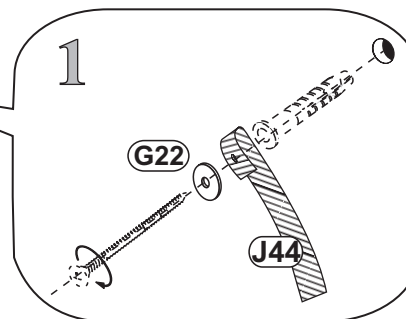
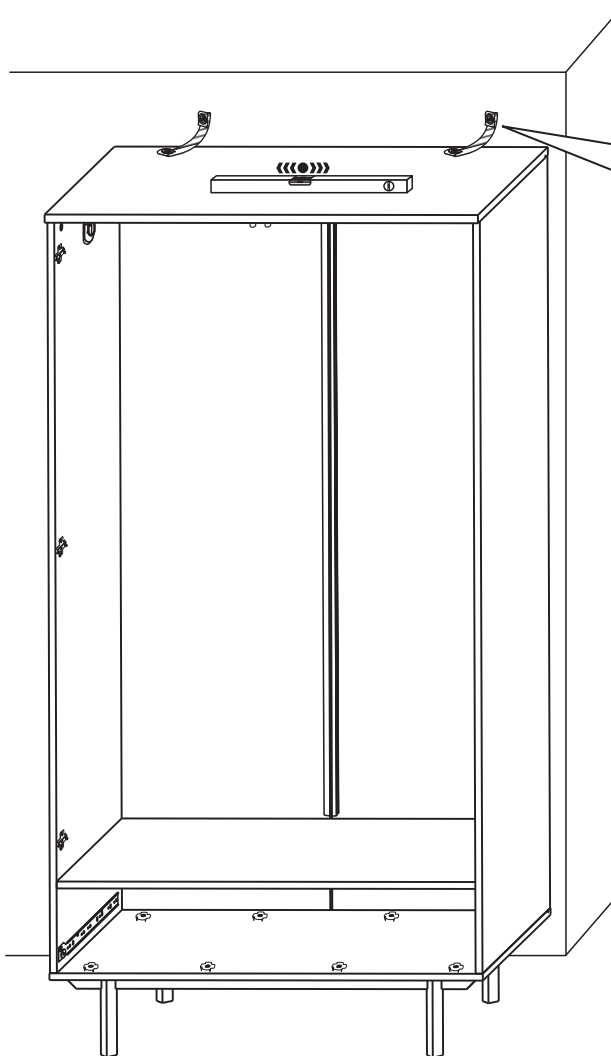

14

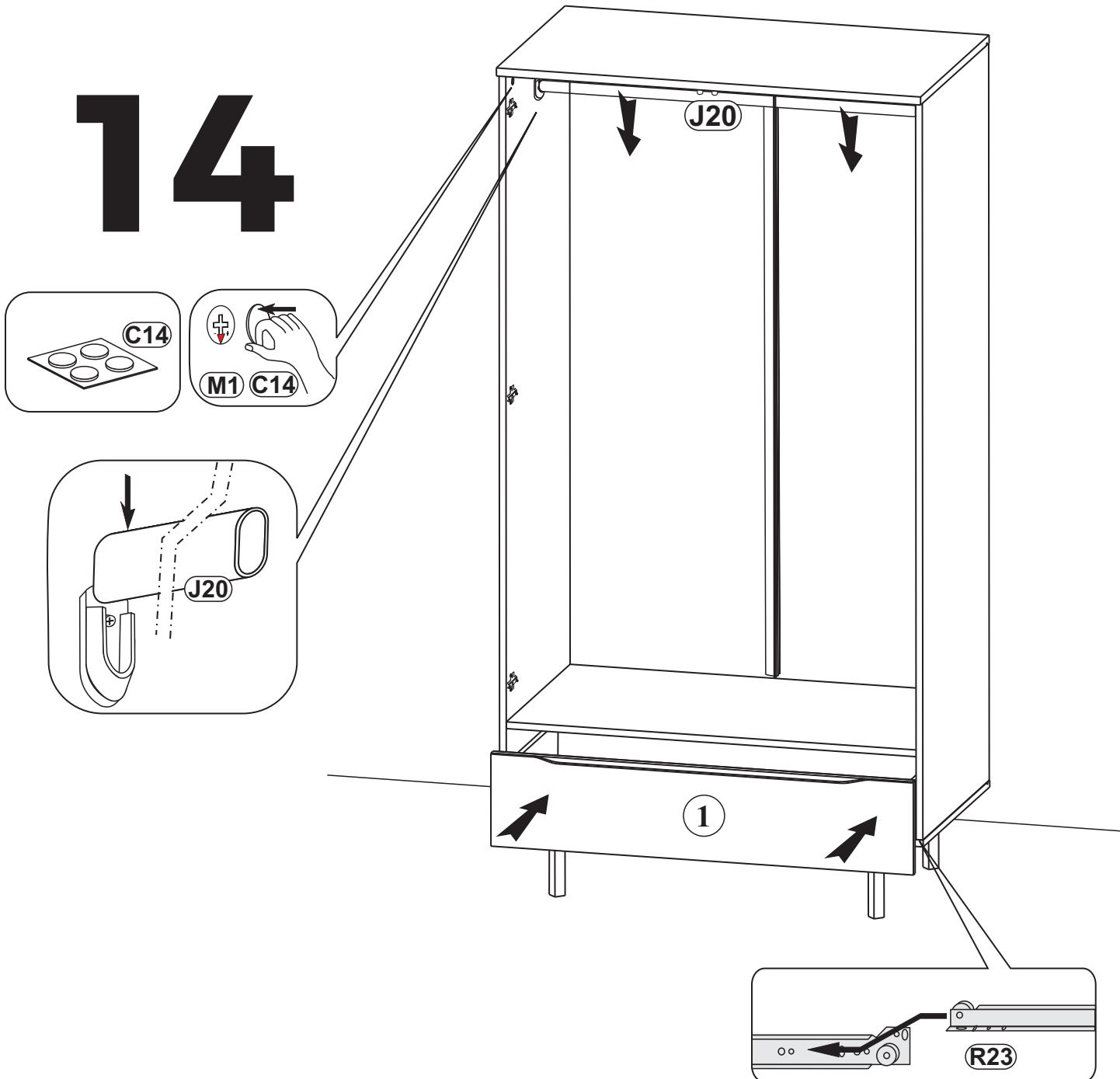

15

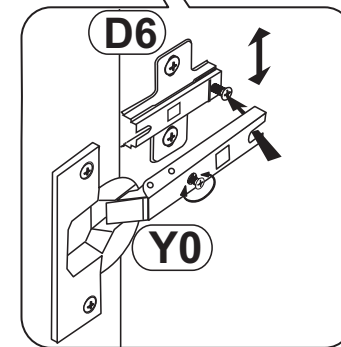
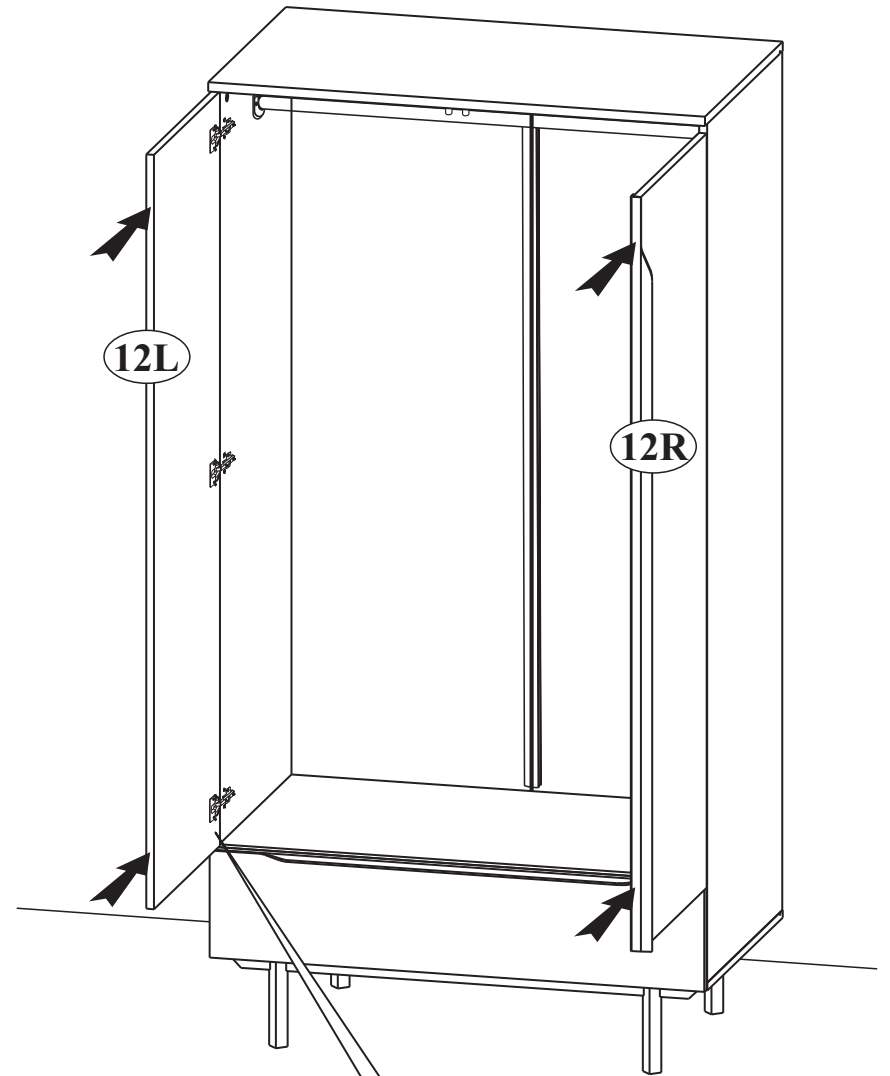
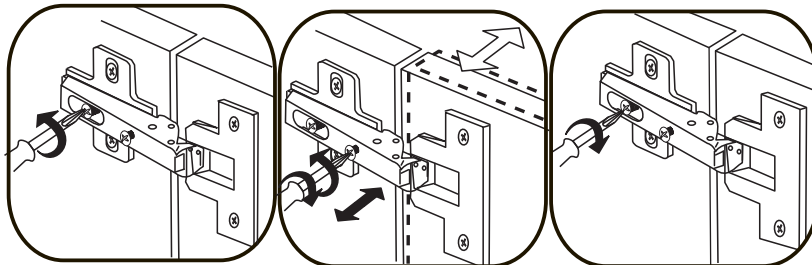
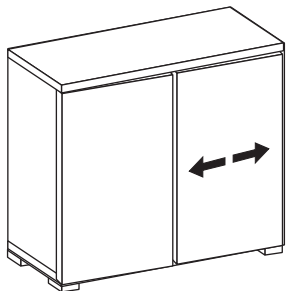
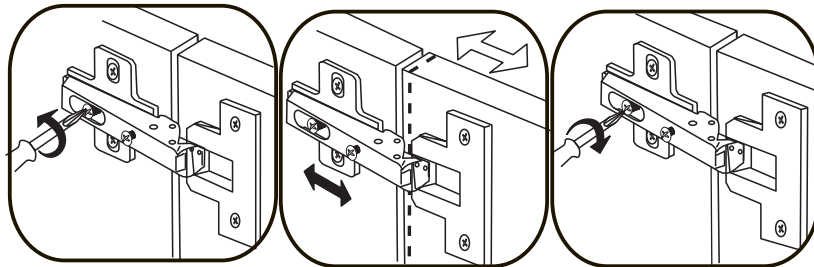
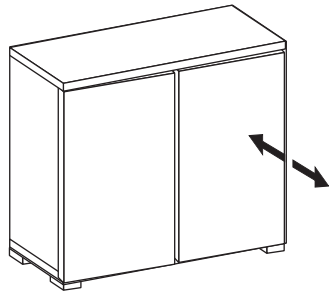
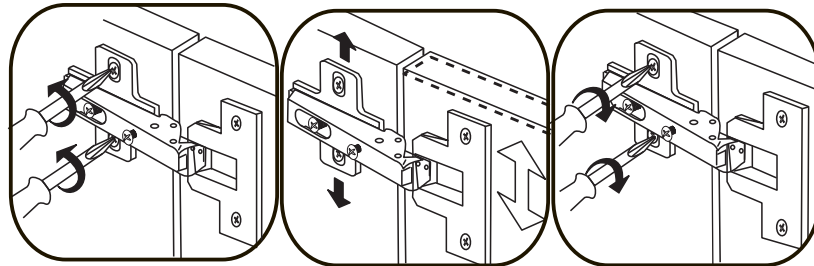
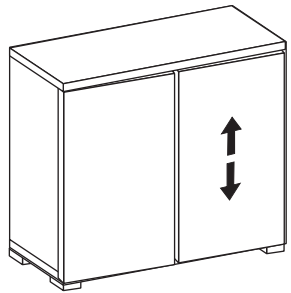

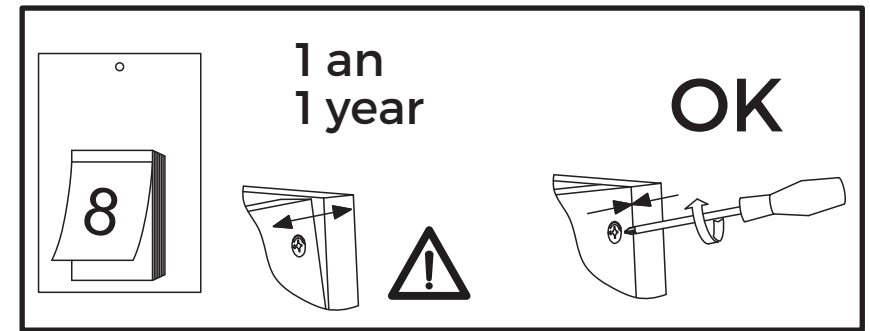
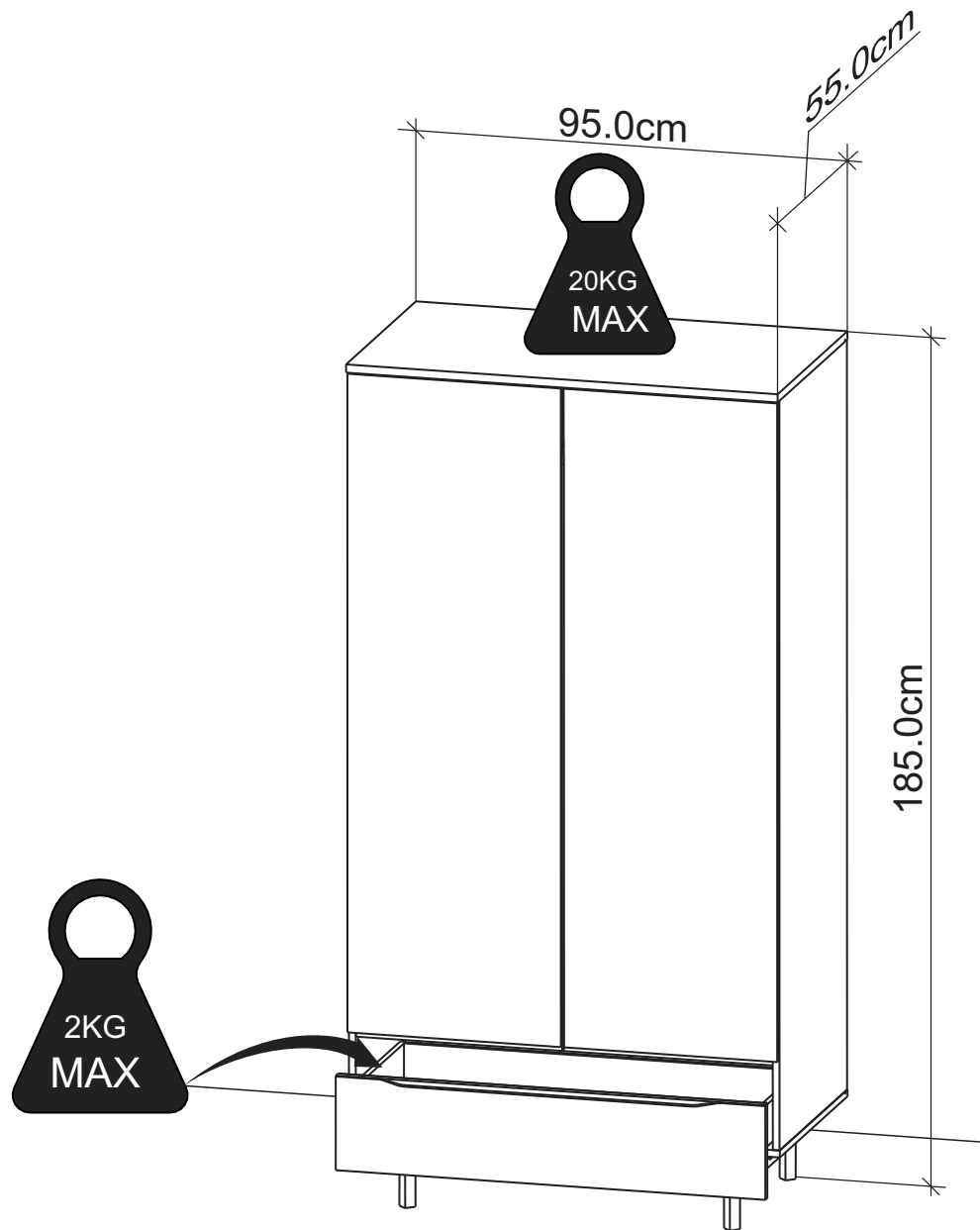

GB

- The unit must be fitted with the wall attachment and be secured prior to use.
- The unit must only be used on a level floor.

FR

- Le produit doit être équipé de la fixation murale et être fixé au mur avant toute utilisation.
- Le produit doit être utilisé à hauteur de plancher.

NL

- Het meubel dient voor gebruik gemonteerd te worden aan de wand met het bijgeleverde materiaal.
- Dit meubel dient alleen op een even vloer gebruikt te worden.

DE

- Bringen Sie zuerst die Wandhalterung an und befestigen Sie das Produkt an der Wand, bevor Sie es verwenden.
- Stellen Sie das Produkt nur auf einem ebenen Untergrund auf.

ES

- La unidad debe estar equipada con la pared y asegúrelas antes de usarlas.
- La unidad sólo debe utilizarse en un nivel piso.