

ROCKETT
St GEORGE

Showstopper

Console Table

Console Table

Console Table

Konsolentisch

Tabla de consola



GB - Recommendations for the continual safe use of this product are stated on the final page of these instructions. Please retain for future reference.

FR - Les conseils d'utilisation de ce produit sont indiqués sur la dernière page de ces instructions. Veuillez les conserver pour vous y référer si besoin.

NL - Aanwijzingen voor veilig gebruik van dit meubel worden toegelicht op de laatste pagina van deze Instructies. Bewaar deze folder goed.

DE - Auf der letzten Seite dieser Anleitung findest du Hinweise für eine langfristig sichere Anwendung dieses Produktes. Bitte bewahre sie gut auf.

ES - Las recomendaciones para el uso continuado de este producto figuran en la última página de estas instrucciones. Por favor, consérvalas para futuras consultas.

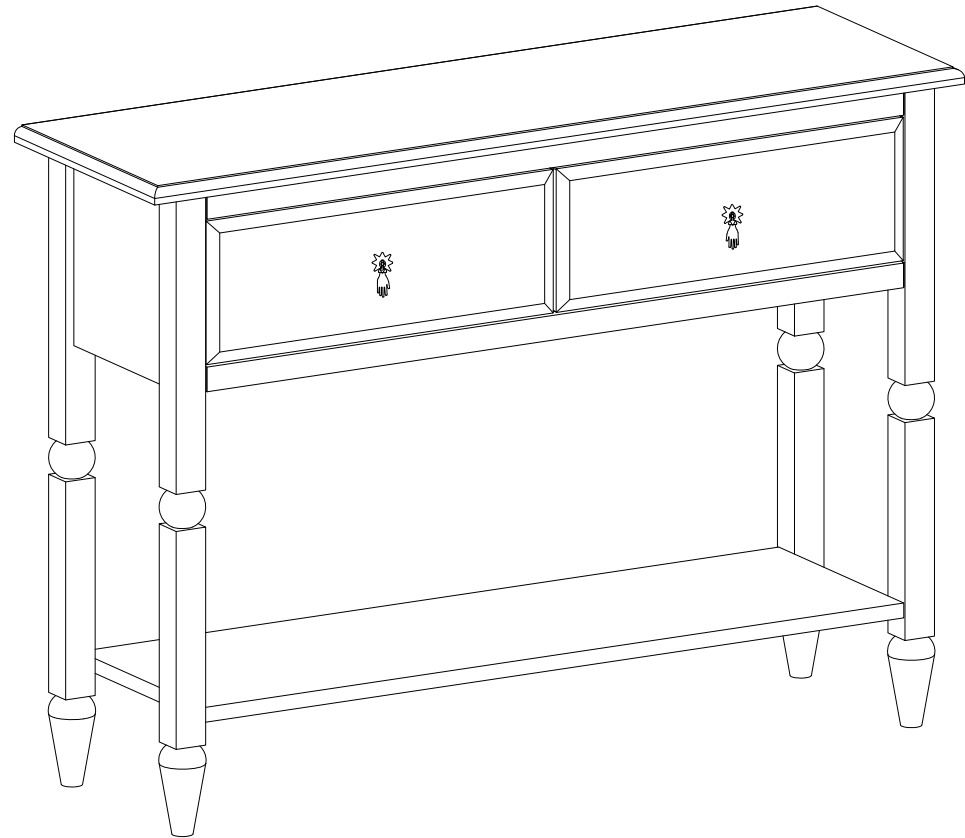



SAFETY DISCLAIMER

GB

- A safety strap / bracket is included with this item.

Please ensure the strap / bracket is attached to the product and the wall to ensure it remains stable at all times during use.

- The unit must only be used on a level floor

FR

- Une sangle / un support de sécurité est inclus dans cet article.

Assurez-vous que la sangle / le support soit fixé au produit et au mur pour s'assurer qu'il reste stable en permanence pendant l'utilisation.

- Le produit doit être utilisé à hauteur de plancher

NL

- Dit product is inclusief veiligheids riempje / haakje.

Zorg ervoor dat het riempje / haakje aan het product en de muur bevestigd wordt zodat het stabiel blijft bij gebruik.

- Dit meubel dient alleen op een even vloer gebruikt te worden.

DE

- Dieses Produkt enthält einen Sicherheitsriemen mit Schlaufe.

Der Riemen und die Schlaufe müssen am Produkt und der Wand befestigt werden, damit das Produkt immer stabil steht.

- Stellen Sie das Produkt nur auf einem ebenen Untergrund auf.

ES

- Incluye una cinta / soporte de seguridad

Asegúrate de que la cinta / soporte esté adherida al producto y a la pared para garantizar que permanezca estable en todo momento durante su uso.

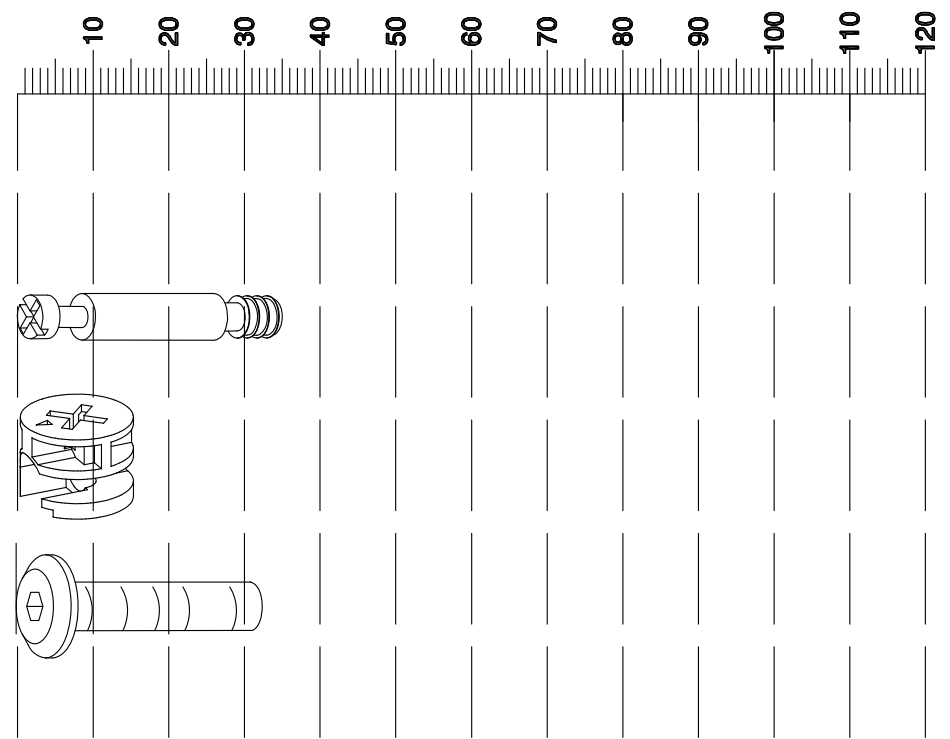

- El producto solo debe usarse en un suelo nivelado

Fixtures and fittings supplied (actual size)			
Ref	Dimensions	Qty.	Spare Qty.
H1	Ø6x35mm	6	
H2	Ø15x12mm	4	
H3	M6x30mm	8	

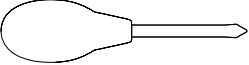

Fixtures and fittings supplied (not to scale)			
Ref	Qty	Spare Qty.	Visual
H5	1		

Fittings not supplied			
Ref	Qty	Spare Qty.	Visual
H6	1		

1x 
00:30 

A

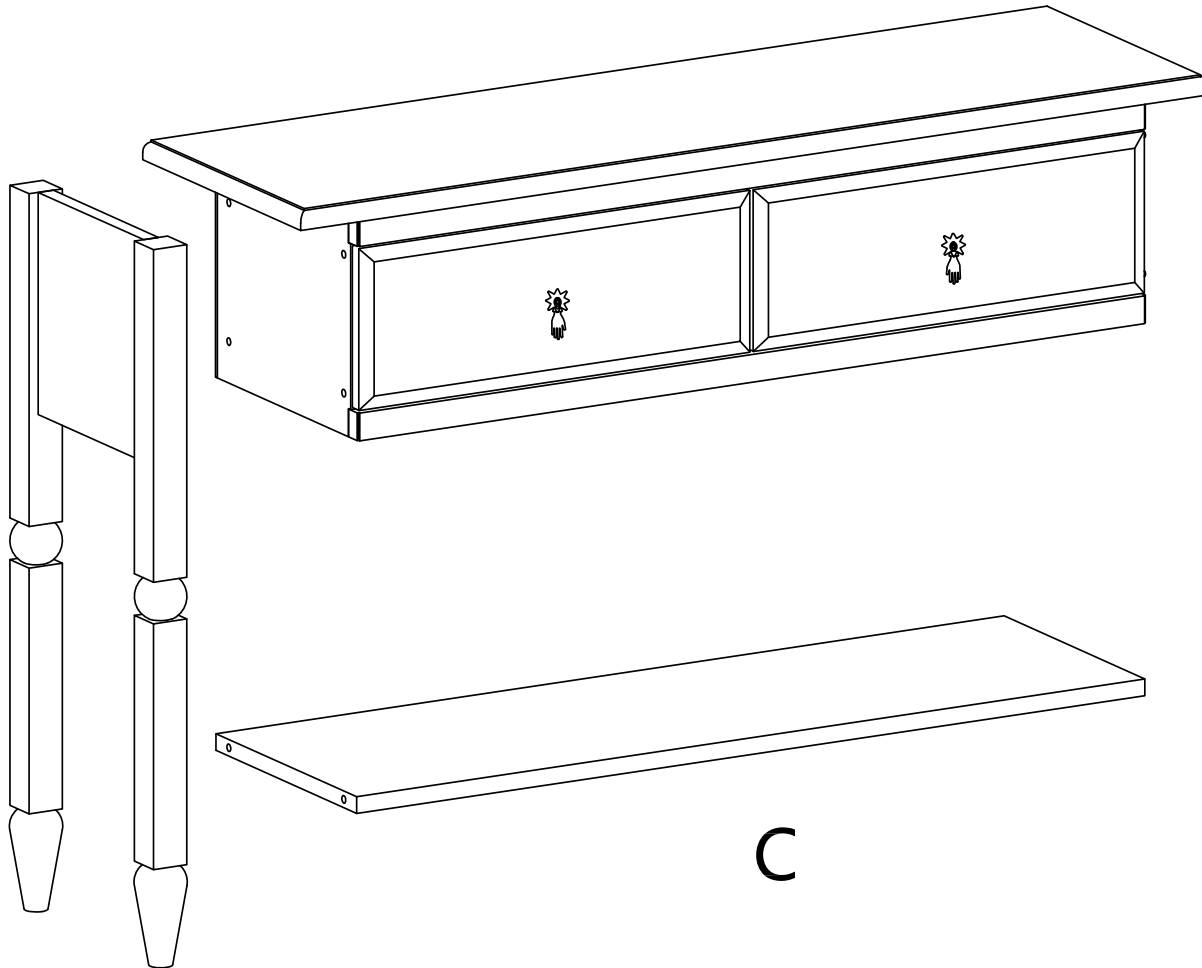

B

B

C

1

A

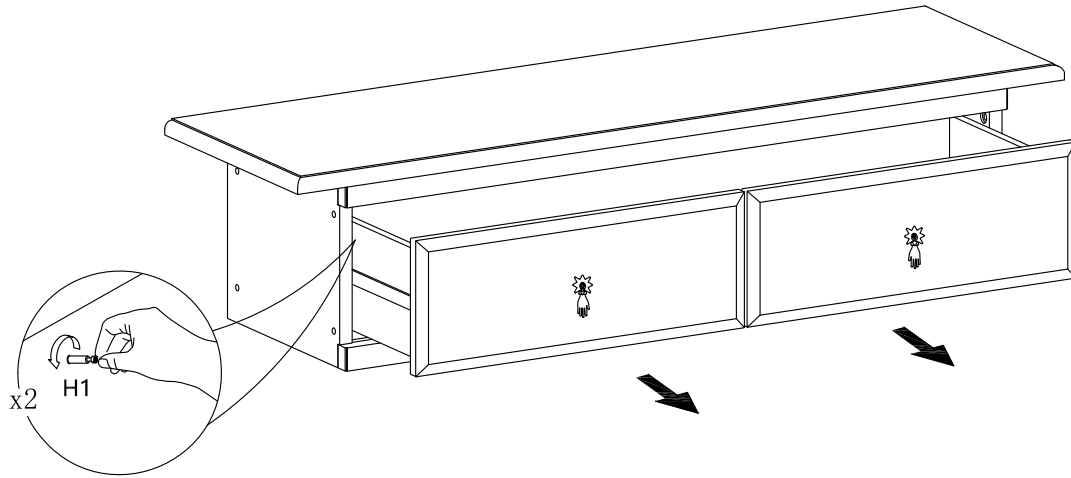

B

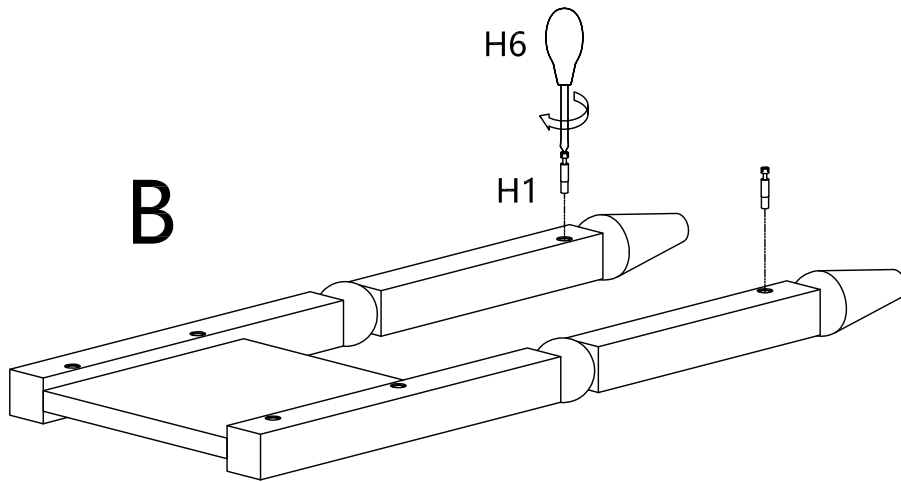

B

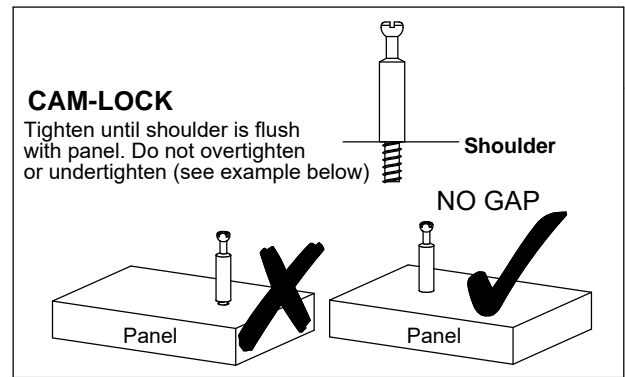
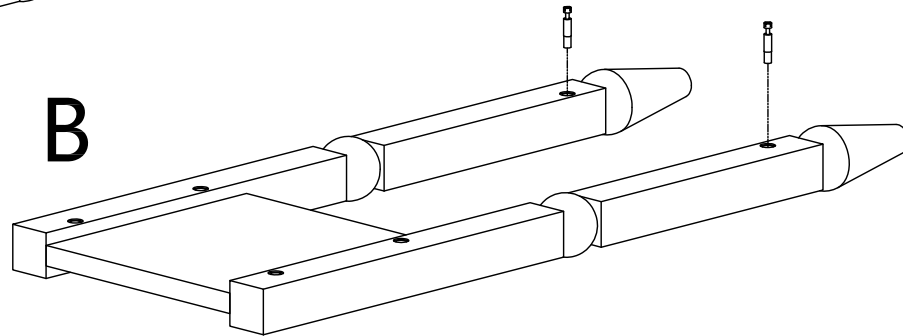

2

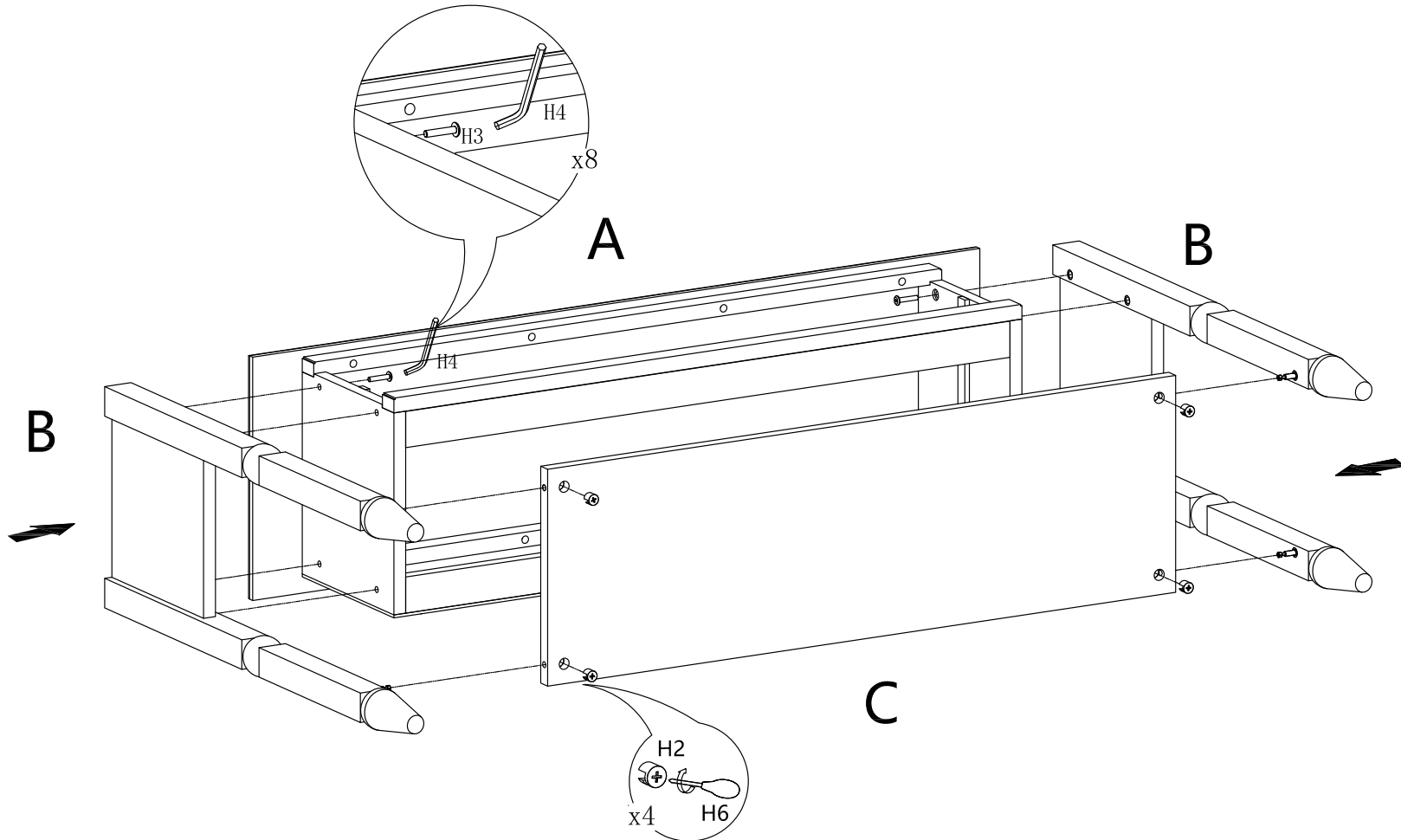
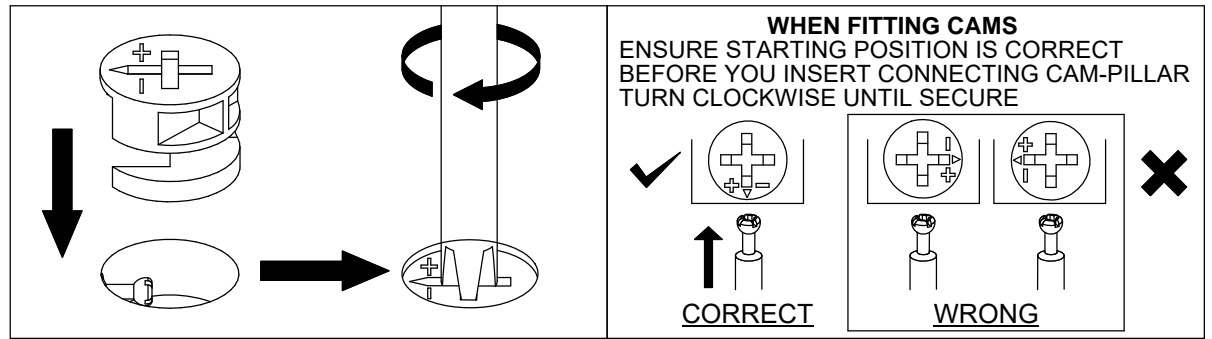

3

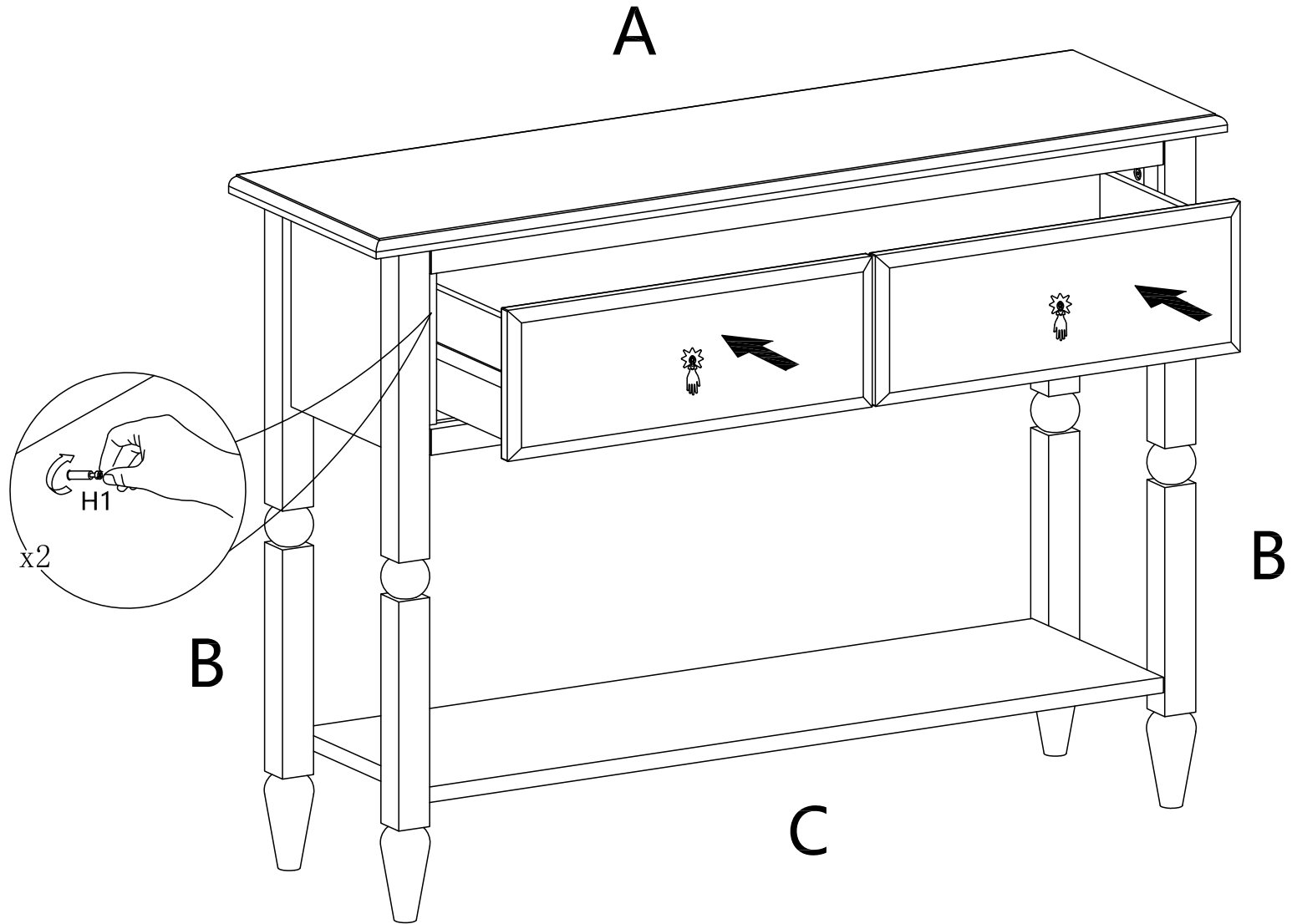

We recommend the use of the wall belt provided for safety reasons. Wall fixings are not included please source suitable fixings for your wall type. If in doubt, please consult a qualified tradesperson. **WARNING:** Always ensure the wall to be drilled is free from hidden electrical wires, water and gas pipes.

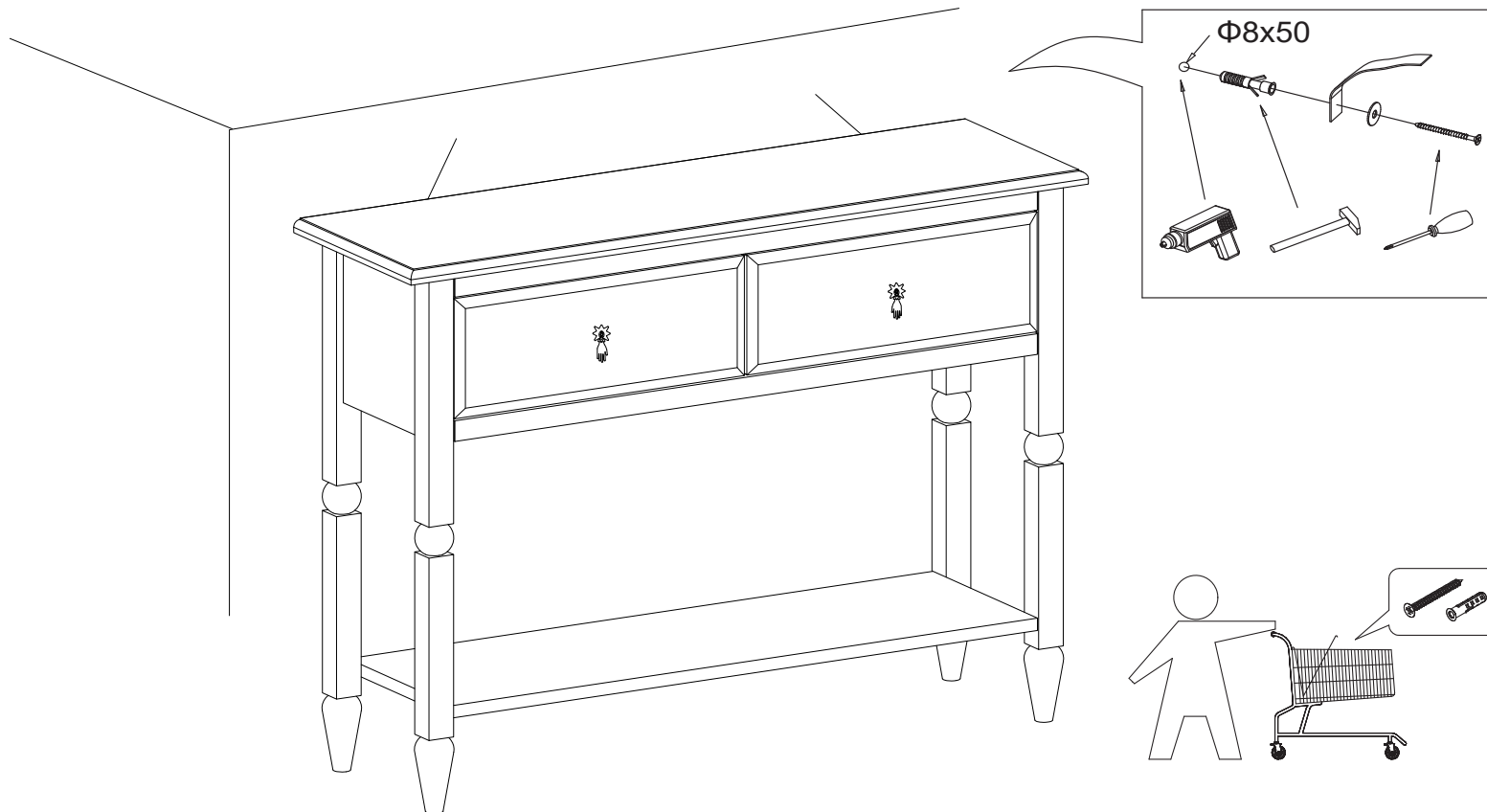
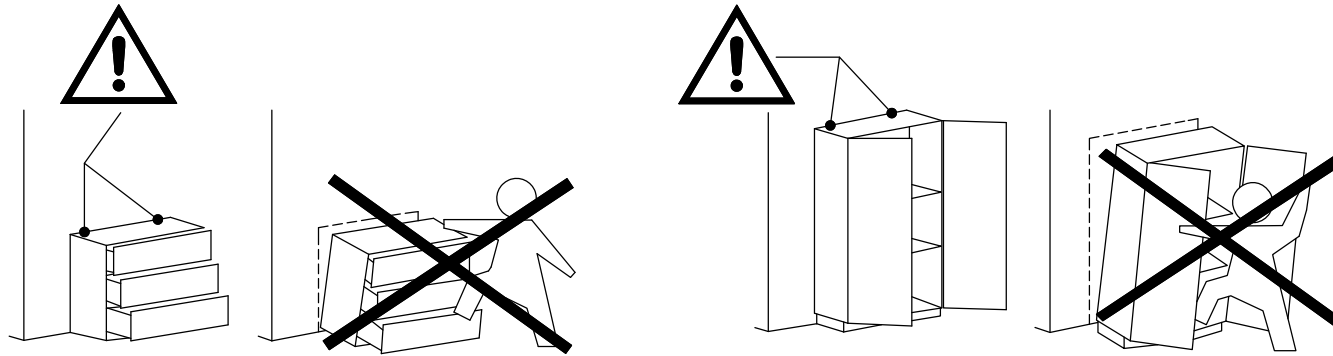

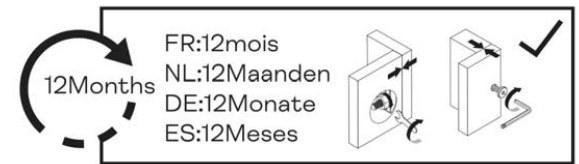

GB - Check regularly that all assembly fastenings are properly tightened and retighten when necessary

FR - Vérifiez régulièrement que toutes les fixations soient bien serrées et resserrez si nécessaire.

NL - Controleer regelmatig of alle bevestigingen goed zijn aangedraaid; draai ze indien nodig opnieuw aan.

DE - Regelmäßig kontrollieren, dass alle Beschläge und Verschraubungen gut festgezogen sind und sie bei Bedarf nachziehen.

ES - Comprueba regularmente que las fijaciones estén bien apretadas y vuelve a apretarlas en caso necesario.

