



# HADEN

ESTD. ENGLAND 1958



## INSTRUCTION MANUAL



# 12L DUAL ZONE AIR FRYER

PRODUCT CODE: 210821



ESTD. ENGLAND 1958

## How Can We Help?

The Haden team is always interested in what you have to say, so why not get in touch?



Call us  
**01909 544 570**



Email us  
**info@haden.com**



Write to us  
**Team Haden, Sabichi Homewares Ltd,  
Priorswell Rd, Worksop, S80 2BY**



Visit us  
**www.haden.com**

# COMPONENTS

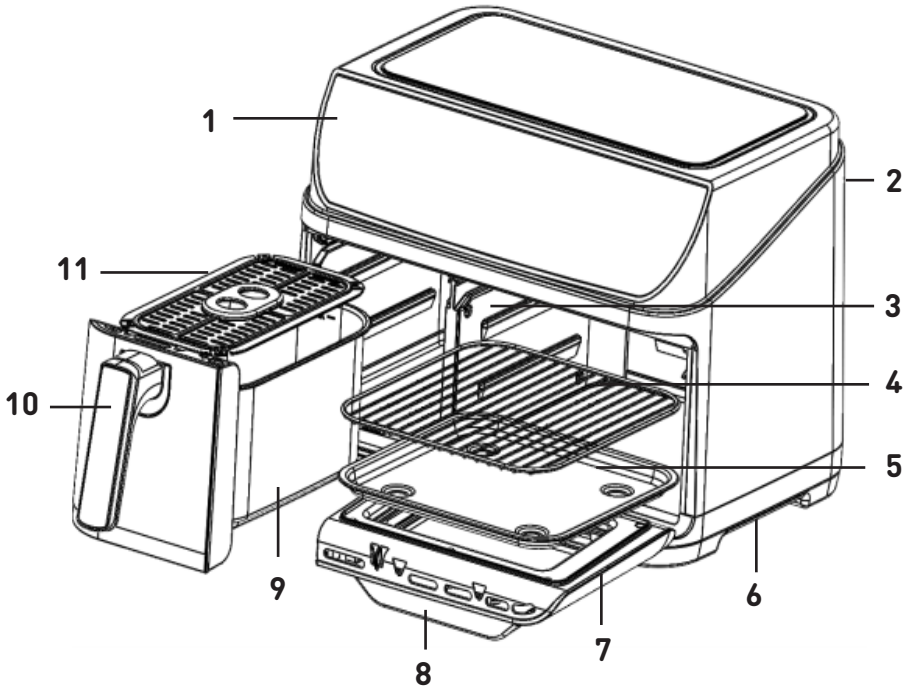

**1.** Control Panel

**2.** Air outlet vents (rear)

**3.** Insulation plate

**4.** Wire shelf

**5.** Oil tray

**6.** Cord storage (underneath)

**7.** Oven door

**8.** Oven door handle

**9.** Basket

**10.** Basket handle

**11.** Grill tray

# SAFETY INSTRUCTIONS

**When using this appliance, the following basic safety precautions should always be taken.**

- Read all instructions.
- Do not touch hot surfaces.
- Never immerse the housing, which contains electrical components and the heating elements, in water nor rinse it under the tap.
- Do not let any water or other liquid enter the appliance to prevent electric shock.
- **WARNING:** This electrical appliance contains a heating function. Surfaces, also different from the functional surfaces, can develop high temperatures. Since temperatures are differently perceived by different persons, this equipment shall be used with **CAUTION**. The equipment shall be touched only at intended handles and gripping surfaces, with heat protection like gloves or similar. Surfaces other than intended gripping surfaces shall get sufficiently time to the cool down before getting touched.
- Always put the ingredients to be fried in the basket, to prevent it from coming into contact with the heating elements.
- Do not cover the air inlet and the air exhaust openings while the appliance is operating.
- Do not fill the frying basket with oil as this may cause a fire hazard.
- Never touch the inside of the appliance while it is operating.
- Check whether the voltage indicated on the appliance corresponds to the local mains voltage in your country before you connect the appliance.
- Do not use the appliance if the plug, the power cord or the appliance itself is damaged.
- If the power cord is damaged, you must have it replaced at a service centre or similarly qualified persons in order to avoid a hazard.
- Do not use outdoors.

- This appliance can be used by children aged from 8 years and above and persons with reduced physical, sensory or mental capabilities or lack of experience and knowledge if they have been given supervision or instruction concerning use of the appliance in a safe way and understand the hazards involved. Children should not play with the appliance. Cleaning and user maintenance should not be made by children unless they are older than 8 and supervised.
- Keep the appliance and its mains cord out of the reach of children when the appliance is switched on or is cooling down.
- Keep the mains cord away from hot surfaces.
- Do not place the appliance on or near a hot gas or electric burner, or in a heated oven.
- Do not plug in the appliance or operate the control panel with wet hands.
- Only connect the appliance to an earthed wall socket. Always make sure that the plug is inserted into the wall socket properly.
- Never connect this appliance to an external timer switch.
- Do not place the appliance on or near combustible materials such as a tablecloth or curtains.
- Do not place the appliance against a wall or against other appliances. Leave at least 10cm free space at the back and sides and 10cm free space above the appliance. Do not place anything on top of the appliance.
- Do not use the appliance for any purpose other than described in this manual.
- Do not let the appliance operate unattended.
- During hot air frying, hot steam is released through the air exhaust openings. Keep your hands and face at a safe distance from the steam and from the air exhaust openings. Also be careful of hot steam and hot air when you remove the frying basket from the appliance.
- The surface below the appliance may become hot during use.
- Immediately unplug the appliance if you see dark smoke coming out of the appliance. Wait for the smoke emission to stop before you remove the frying basket from the appliance.

- Place the appliance on a horizontal, level and stable surface.
- This appliance is intended for normal household use only. It is not intended for use in environments such as staff kitchens, offices, farms or other work environments. Nor is it intended to be used by clients in hotels or other similar environments.
- Always unplug the appliance after use.
- Let the appliance cool down for approx. 30 minutes before you handle or clean it.
- If the appliance is used improperly or if it is not used according to the instructions in the user manual, the warranty becomes invalid and refuses any liability for any damage that is caused.
- The appliances are not intended to be operated by means of an external timer or separate remote-control system

## SAVE THESE INSTRUCTIONS

# INTRODUCTION

This Air Fryer provides an easy and healthy way of preparing a wide assortment of food - with little or no oil! The air fryer uses hot air, in combination with high-speed air circulation, and a top grill to prepare your dishes quickly and easily. The ingredients are heated from all sides, at once, and there is no need to add oil in most cases.

## BEFORE FIRST USE

1. Remove all packing material.
2. Remove any stickers or labels from the appliance – other than the rating label.
3. Thoroughly clean the basket, grill tray, wire shelf and oil tray with hot soapy water using a non-abrasive sponge.
4. Wipe the inside and outside of the appliance with a moist cloth.
5. Dry all parts thoroughly before use.
6. Do not fill the appliance with oil or frying fat. This appliance operates using hot air and requires very little to no oil.

**Note: Do not remove the silicone pads from the grill tray.**

# CONTROL PANEL

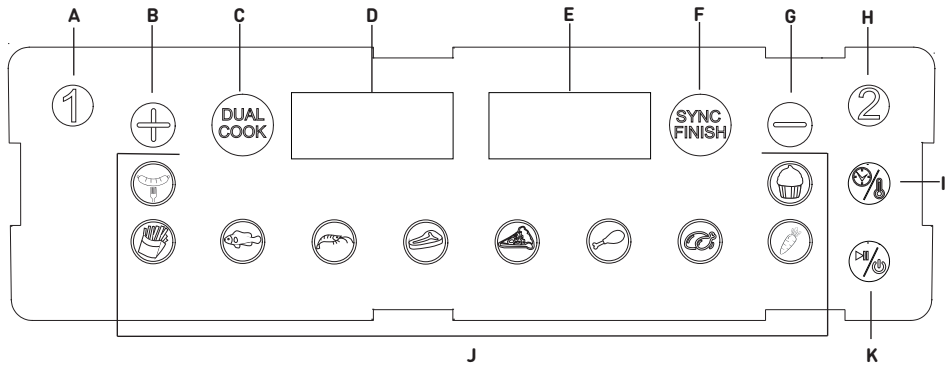











- A.** Basket 1 Button
- B.** Plus Button
- C.** Dual Cook Button
- D.** Basket 1 - Display
- E.** Basket 2 - Display
- F.** Sync Finish Button
- G.** Minus Button
- H.** Basket 2 Button
- I.** Timer / Temperature Button
- J.** Auto Menu Buttons
- K.** Start / ON / OFF button

# PREPARING FOR USE

1. Place the Air fryer on a stable, horizontal and level surface that is also heat resistant.
2. Remove the basket and insert the grill tray inside the basket.
3. Do not remove the silicone pads from the grill tray.
4. Insert the basket back into the Air fryer.
5. Slide the Oil tray in to the bottom of the oven before sliding in the wire shelf and closing the door.
6. Ensure that the cable is clear of obstacles and not hanging off the edge of the counter.
7. Do not fill the basket with oil or any other liquid.
8. Do not put anything on top of the Air fryer. This disrupts the airflow and affects the air-frying result.
9. Ensure that nothing is blocking the outlet vent.

# USING THE AIR FRYER

1. Plug the air fryer into the mains socket. The air fryer will beep and the control panel will light up, before going into standby mode with only the  lit up.
2. Touch the  button to turn the Air fryer on, the indicator lights for basket 1 & 2 will be illuminated. The screens will display "----."
3. Press  and the indicator light for basket 1,  menu and Dual Cook button will blink. The display screen for basket 1 will display the temperature and time for the  menu 180°C/23min. Meanwhile the screen for basket 2 will show "----".
4. Press one of the 10 selectable Auto Menu buttons. After selection the indicator icon will flash and the display will change to the preset temperature and timing.

5. To adjust the temperature or time, press  button. Adjust the temperature using the   buttons. Then press  again to adjust the time.
6. If basket 2 is to be used repeat steps 3 through to 5 but pressing  instead.
7. Press  to start the air fryer working.
8. When the timer has elapsed, the fan will continue to operate for approximately 1 min to cool the air fryer. The display will show OFF and the heating element will stop working. The air fryer will beep before the air fryer enters standby mode.
9. Remove the basket from the air fryer and place it on a heat-resistant surface.
10. Check if the food is ready:
  - If the food is not ready yet, return the basket to the air fryer, and turn back on for a couple of minutes until ready.
  - If the food is ready empty the basket into a bowl or onto a plate. Take care if tilting the basket as any excess oil that has collected on the bottom will leak onto the food.



**CAUTION:** Take care when tilting the basket as the grill tray may move or fall out of the basket.

**CAUTION:** DO NOT touch the basket during and for some time after use, as it gets very hot. Only hold the basket by the handle.

11. Press and hold the  power button to stop the air fryer cooking. The air fryer will beep and both zones stop cooking at the same time, the display screen shows OFF, and the air fryer will beep before the air fryer enters standby mode.





**Note:** If there is a power cut or the air fryer is unplugged during use the display will go off. Once power is back or plugged back in, the air fryer will continue the program previously set.

## Start / pause

1. To pause the air fryer, press .
2. To restart press the  again.



## Sync Finish

Cook different foods in each compartment with different times and temperatures, use the 'Sync Finish' function to ensure that both compartments finish cooking at the same time.

1. Press  and set the cooking program.
2. Press  and set the cooking program.
3. Press the  button.
4. Press the  to start cooking.
5. The basket with the shorter cooking time will display "Hold" until the other basket has reached the sync time.

## Dual Cook

Use the 'Dual Cook' function when using both compartments to cook the foods, cooking will finish at the same time for both compartments.

1. Press  and set the cooking program.
2. Press the  button
3. Press the  to start cooking.

## Air Fryer Safety Switch

The air fryer has a safety switch in the basket and oven door. This stops the air fryer from accidentally turning on whenever the basket is not properly situated inside the air fryer or the oven door is open. Before using your air fryer, please ensure that the grill plate is inside the basket and the basket is fully closed.

## Auto Off Function

The Air fryer is fitted with an automatic switch off function. This will activate when the timer has elapsed, the air fryer will beep and go in Standby automatically.

**Note:** To turn the unit back on press the  button.







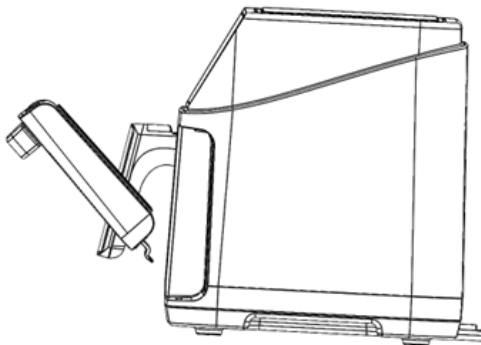



# REMOVEABLE OVEN DOOR

For easy cleaning the oven door can be removed from the air fryer.

1. Allow the Air fryer to cool fully before removing the door.
2. Open the door at a 45° angle and the door can be lifted away from the body of the air fryer.
3. To refit the door place the door back into the slot in the air fryer at a 45° angle.



# PRE-SET COOKING FUNCTIONS

ICON	FUNCTION	DEFAULT TIME (MIN)	DEFAULT TEMPERATURE (°C)	Min-Max Amounts (g)
	French fries	20	200	500 - 600
	Drumsticks	23	180	500 - 600
	Steak	15	180	200 - 400
	Cake	15	170	120 - 160
	Prawns	14	200	400 - 500
	Fish	18	200	500 - 600
	Pizza	17	200	500 - 600
	Vegetables	8	160	140 - 160
	Sausages	23	180	500 - 600
	Chicken	45	200	600 - 800

**Note:** Keep in mind that these settings are only for reference. As ingredients differ in origin, size, shape as well as brand, we cannot guarantee the best setting for your ingredients.

# COOKING TIPS

- Try cooking food ingredients of similar sizes together. Large food will require more cooking time than smaller food.
- Smaller ingredients usually require a slightly shorter preparation time than larger ingredients.
- A larger amount of ingredients only requires a slightly longer preparation time, a smaller amount of ingredients only requires a slightly shorter preparation time.
- Shaking smaller ingredients halfway through the preparation time optimises the end result and can help prevent unevenly fried ingredients.
- You can coat fresh potatoes with a little oil for a crispy result.
- Fry your ingredients in the air fryer within a few minutes after you have added the oil.
- Do not prepare extremely greasy ingredients such as sausages in the air fryer.
- Snacks that can be prepared in an oven can also be prepared in the air fryer.
- The optimal amount for preparing crispy fries is 500 grams.
- Use pre-made dough to prepare filled snacks quickly and easily. Pre-made dough also requires a shorter preparation time than home-made dough.
- You can also use the air fryer to reheat ingredients by setting the temperature to 150°C and the timer to about 15 minutes.

# MAKING HOME-MADE FRIES

For the best results, we advise to use pre-baked fries. If you want to make home-made fries, follow the steps below:

1. Peel the potatoes and cut them into fries.
2. Soak the fries in a bowl of water for at least 30 minutes, take them out and dry them with kitchen paper.
3. Pour 1/2 tablespoon of olive oil in a bowl, put the fries on top and mix until they are lightly coated with oil.
4. Remove the fries from the bowl with tongs so that excess oil stays behind in the bowl. Place the fries in the basket.

**Note:** Do not tilt the bowl to place all the fries in the basket, to prevent excess oil from collecting at the bottom of the basket.

5. Air fry the fries.

# CLEANING AND MAINTENANCE

Clean the appliance after every use.

The frying tray, basket and the inside of the appliance has a non-stick coating. Do not use metal kitchen utensils or abrasive cleaning materials to clean them, as this may damage the non-stick coating.

- 1 Remove the mains plug from the wall socket and let the appliance cool down.  
**Note:** Remove the basket to let the air fryer cool down quickly.
- 2 Wipe the outside of the appliance with a moist cloth.
- 3 Clean the grill tray and basket with hot soapy water and a non-abrasive sponge.

**Tip:** If dirt is stuck to the basket, or at the bottom of the grill tray, fill the grill tray with hot water and with some washing up liquid. Put the basket in the grill tray and let it soak for approx. 10 minutes.

- 4 Clean the inside of the appliance with moist cloth.
- 5 Clean the heating element with a cleaning brush to remove any food residues.
- 6 Do not submerge the air fryer in water!

## STORAGE

1. Unplug the appliance and let it cool down.
2. Make sure all parts are clean and dry.
3. Store in a cool and dry place.

# TROUBLESHOOTING

Problem	Cause	Solution
<b>The air fryer does not work.</b>	The appliance is not plugged into the mains.	Put the mains plug in an earthed wall socket.
	You have not set the timer.	Turn the timer knob to the required Preparation time to switch on the appliance.
<b>The ingredients fried with the air fryer are not done.</b>	The amount of the ingredients in the pot is too much.	Put smaller batches of ingredients in the pot. Smaller batches are fried more evenly.
	The set temperature is too low.	Turn the temperature control knob to the required temperature setting
	The preparation time is too short.	Turn the timer knob to the required preparation time
<b>The ingredients are fried unevenly in the air fryer.</b>	Certain types of ingredients need to be shaken halfway through the cooking time.	Ingredients that lie on top of or across each other (e.g. fries) need to be shaken halfway through the cooking time.
<b>Fried snacks are not crispy when they come out of the air fryer.</b>	You used a type of snack meant to be prepared in a traditional deep fryer.	Use oven snacks or lightly brush some oil onto the snacks for a crispier result.
<b>I cannot slide the pot into the appliance properly.</b>	There is too much food in the tray.	Do not fill the tray beyond the Max amount indicated on the product.
	The pot is not placed in the pan correctly.	Push the pot down into the pan until you hear a click.

# TROUBLESHOOTING

Problem	Cause	Solution
<b>White smoke comes out of the appliance.</b>	You are preparing greasy ingredients.	Pay attention that the temperature is well-controlled to be under 180°C when you fry greasy ingredients in the air fryer.
	The pan still contains greasy residues from previous use.	White smoke is caused by grease heating up in the pan. Make sure you clean the pan properly after each use.
<b>Fresh potato fries are fried unevenly in the air fryer.</b>	You did not soak the potato sticks properly before you fried them.	Soak the potato sticks in a bowl of water for at least 30 minutes; take them out and dry them with kitchen paper.
	You did not use the right potato type.	Use fresh potatoes and make sure they stay firm during frying.
<b>Fresh potato fries are not crispy when they come out of the air fryer.</b>	The crispiness of the fries depends on the amount of oil and water in the fries.	Make sure you dry the potato sticks properly before you coat them with oil.
		Cut the potato into thinner sticks for a crispier result.  Add slightly more oil for a crispier result.

**Note:** When using the Air fryer for the first time, a slight smoke or odour may be emitted. This is normal and will soon subside. Ensure that there is sufficient ventilation around the fryer

# TECHNICAL DETAILS

<b>Product Code</b>	210821
<b>Rated Voltage</b>	220-240V~ 50-60Hz
<b>Rated Power</b>	2400W
<b>Capacity</b>	3.5L Basket & 8L Oven

**CE** Sabichi Homewares Ltd  
5 Wadsworth Road, Perivale, Middlesex UB6 7JD  
20 Harcourt Street, Dublin D02 H364

## WASTE ELECTRICAL RECYCLING

This symbol indicates the product is classed as Electrical or Electronic Equipment and should not be disposed of with other household waste.



The Waste Electrical and Electronic (WEEE) Directive has been introduced across the EU:

- To recycle waste electrical products using the best available recovery and recycling techniques.
- To minimise the impact to on the environment
- To treat any hazardous substances
- To avoid increasing landfill

WEEE product should be disposed of by handing it over at a designated collection point. For more information about where to drop off your waste product for recycling please contact you local authority.

# WARRANTY (UK & IRELAND ONLY)

This product is guaranteed for 2 years from the date of original purchase. If the product fails within this period due to faulty materials or workmanship, it will be repaired, replaced or refunded at our discretion. Proof of purchase will be required.

## **This warranty applies only to:**

- Product installed and used in accordance with the instructions contained in this manual.
- Product used for domestic purposes only.
- Product purchased in the UK and Ireland.

## **This warranty does not cover:**

- Cosmetic damage.
- Normal wear and tear of consumable parts.
- Incorrect voltage supply or power surges.
- Customer misuse, modifications or adjustments.
- Products with unreadable or removed serial numbers.

Haden disclaims any liability for incidental or consequential loss or damages.

## **In the event of a problem:**

- Please refer to the troubleshooting tips section within your user guide for help and guidance.
- If you are still unable to resolve the problem, please contact our technical support team for assistance.

## **When contacting Haden please provide:**

- Product model number. Model & serial numbers can be found on the product rating label.
- Date of purchase.
- Complete description of the problem.

This information will help our team assist you more quickly.

**Help Line:** 01909 544 570  
**Opening Hours:** Monday - Friday 9.30am – 5pm  
**Email:** info@haden.com



