

CHARLES
BENTLEY

EST. 1860



excellent
**EVERY
TIME**

ottimo[🔥]
USER GUIDE

**Ottimo 415
Charcoal BBQ**

BBQCHARC07

 **ottimo**



OTTIMO
MILANO
ITALY

excellent
**EVERY
TIME**

share

BBQ
lovers

FLAVOUR

**SEAR
SMOKE
BROIL**

grilled to
PERFECTION

CONTENTS



GETTING
STARTED
PAGES 4 - 5



MAINTENANCE
INSTRUCTIONS
PAGE 6



WARRANTY
PAGE 6

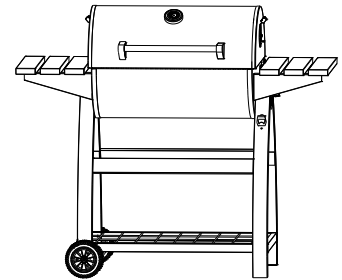

WHAT'S IN
THE BOX
PAGES 7 - 10



ASSEMBLY
GUIDE
PAGES 11 - 18

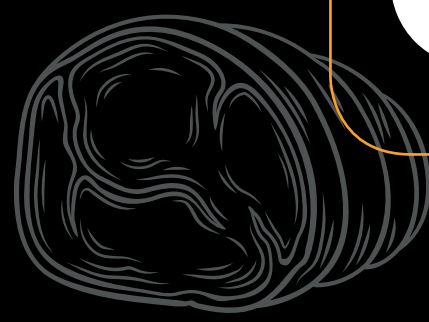

GENERAL SAFETY



Important: Failure to follow these safety instructions may result in serious injury, property damage, or voiding of your warranty. Please read carefully before using your barbecue.

Outdoor Use Only

This barbecue is designed for **outdoor use only**. **NEVER use indoors**, in garages, tents, caravans, or enclosed spaces, due to risk of carbon monoxide poisoning.

Stable Positioning

Always place the BBQ on a **flat, stable, and non-combustible surface**, away from overhanging branches, fences, or structures. Keep at least 1.5 metres from any combustible materials.

Wind Protection

Set up your BBQ in a sheltered location, out of direct wind, to maintain flame control.

Lighting the BBQ

- Only use approved BBQ firelighters or ignition cubes.
- **DO NOT** use petrol, paraffin, methylated spirits, or other flammable liquids to light or re-light the barbecue.
- Follow the instructions provided on your charcoal or briquette fuel packaging.

Fuel Quantity

Use a maximum of 1kg of charcoal briquettes per charcoal pan.

Preheating

Do not cook until the charcoal is fully lit and has developed a light grey ash coating (approximately 15–20 minutes).

During Use

- **DO NOT** move the BBQ while it is hot or in operation.
- Always use heat-resistant oven mitts when handling hot parts or adjusting vents.
- Never leave the BBQ unattended when in use.
- Keep a bucket of sand or a fire extinguisher nearby in case of emergency.
- Keep children and pets at least 1.5 metres away from the BBQ at all times.

Lid Usage

DO NOT place the lid on the BBQ until the flames have died down and the coals are burning evenly.



WARNINGS

- **NEVER** use this BBQ indoors or in enclosed spaces – burning charcoal produces carbon monoxide, which is fatal.
- **DO NOT** use petrol or spirits for lighting or relighting.
- Wait until charcoal is fully lit and covered in ash before cooking.
- **DO NOT** move the BBQ while in use.
- Keep children and pets at a safe distance.
- Place only on a level, stable surface.

GETTING STARTED

PREPARING YOUR GRILL BEFORE FIRST USE

Before cooking with your ottimo BBQ for the first, the following steps must be followed carefully to cure the finish and season the interior steel, improving the durability of your BBQ. Failure to do so may damage the finish and/or impart metallic flavours to your food.

- Brush all interior surfaces, including grills and grates, with vegetable cooking oil.
- Build a small fire on the charcoal pan, making sure not to lay coals directly against the walls.
- Preheat the barbecue for at least 30 minutes, maintaining the charcoal until it is fully incandescent (covered with grey ash).

LIGHTING

Regular briquettes, instant light briquettes, or lumpwood may be used as fuel for your ottimo BBQ.

- When igniting regular briquettes or lumpwood charcoal, **DO NOT** use firelighters that contain petroleum or chemical additives, as these can taint your food.
- **DO NOT** use a chimney starter for instant light briquettes.
- Only use firelighters specifically designed for barbecue use and free from petroleum or chemical additives.
- **WARNING:** Burning charcoal produces carbon monoxide. Always use your barbecue outdoors in a well-ventilated area.
- **WARNING:** NEVER use spirit, petrol, or other flammable liquids to light or relight your barbecue.

BUILDING YOUR FIRE

1. Arrange the charcoal briquettes or lumpwood into a pyramid shape on the charcoal grate.
2. **Solid Fire Starters:** Place the fire starter at the base of the pyramid. Light the fire starters in several locations to ensure an even burn.
3. **Liquid or Gel Fire Starters:** Coat the briquettes or lumpwood with the liquid or gel according to the manufacturer's instructions. Only apply fire starters when the charcoal is cold.
4. **NEVER** add charcoal lighter fluid or similar substances to hot or warm coals – this can be extremely dangerous.
5. Once the charcoal is fully ignited and covered with a grey ash layer, spread it evenly using a long-handled BBQ tool.

You are now ready to cook!

Always use caution when handling hot coals to prevent injury.

AFTER USE

- Allow charcoal to burn out naturally and cool completely before disposal.
- **DO NOT USE WATER** to extinguish hot coals – this may cause damage to the BBQ and release steam or ash.
- Only remove ashes when they are completely cold.
- Dispose of ashes in a non-combustible container.

MAINTENANCE INSTRUCTIONS

CLEANING

- The frequency of cleaning depends on how often the grill is used.
- After cooking and once the unit has cooled, clean out all remaining ashes – ashes retain moisture, which can cause premature rusting and decay if not removed.
- Always ensure the coals and ashes are completely extinguished and cool before cleaning inside the unit.
- Dispose of ashes only when completely cool, in a metal container, away from combustible materials.
- Avoid applying water to hot grill surfaces to prevent damage or warping.
- Thoroughly rinse the interior with water and allow it to air dry before using again.
- Wipe the interior surfaces with a soft cloth or paper towels after cleaning.
- **DO NOT** use abrasive cleaners or metal scrapers that may damage the paint or finish.

SURFACE CARE

- Inspect regularly for signs of rust, corrosion, or damage, and do not use the grill if any structural parts are compromised.
- Rust may appear on the inside of your grill. Maintaining a light coat of vegetable oil on the interior surfaces will help protect it.
- Exterior surfaces may require occasional touch-ups with commercially available high-temperature black paint.
- **DO NOT** paint the interior of the grill.

STORAGE

- Ensure the BBQ is completely cool and dry before storing.
- Store in a dry, sheltered location, ideally under a protective BBQ cover to extend product life.

WARRANTY

For full details and to register for your extended warranty please visit charlesbentley.com/warranty

Please retain your receipt/proof of purchase for all warranty claims.



WHAT'S IN THE BOX





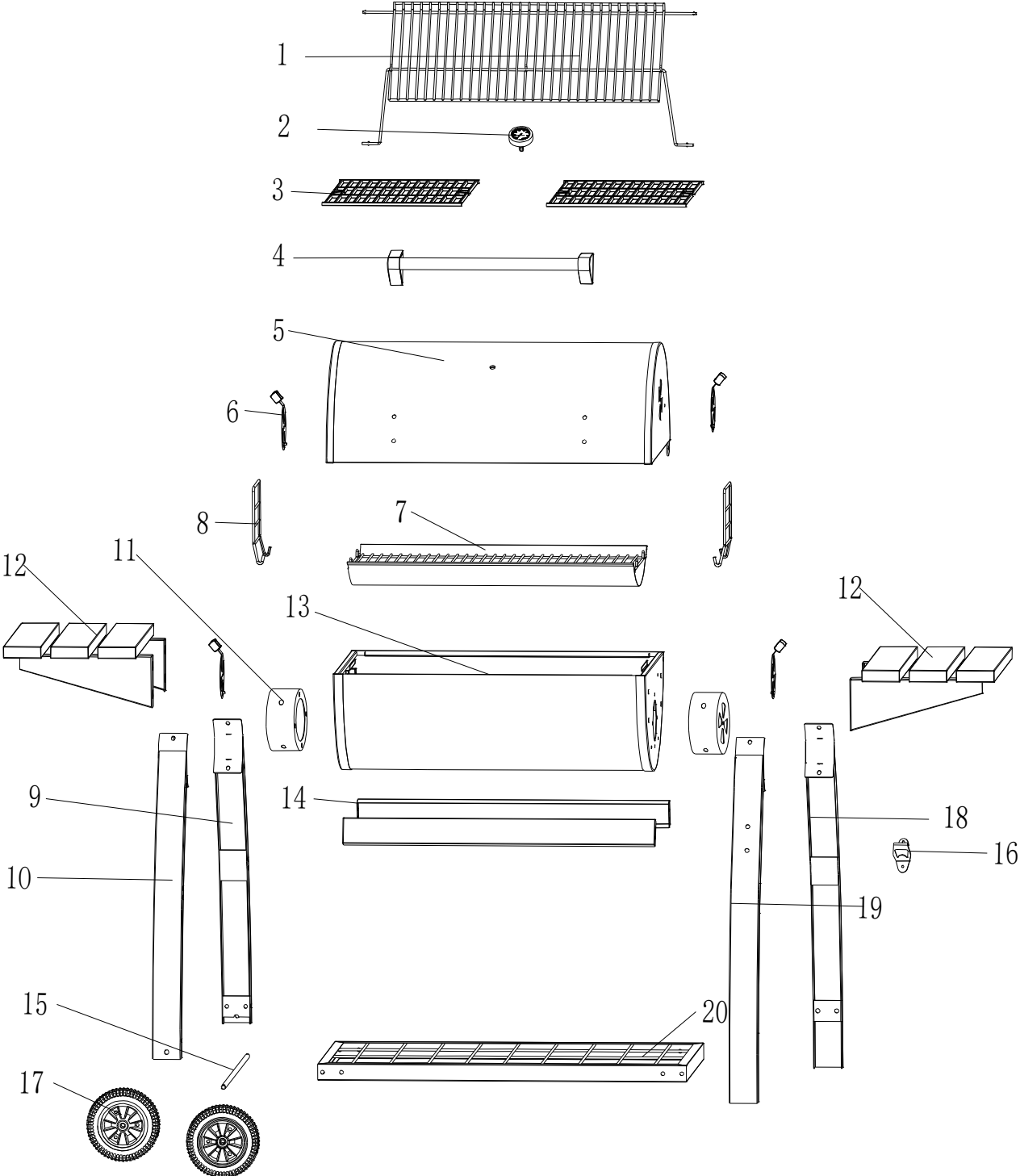





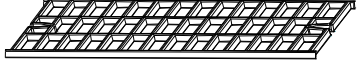
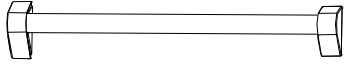
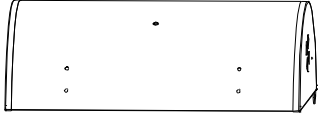
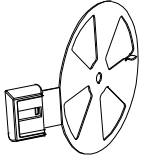
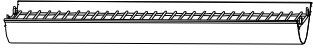

PARTS DIAGRAM

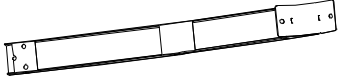

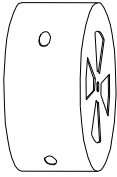
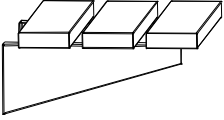
PARTS LIST

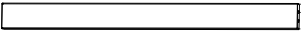
WHAT'S IN THE BOX

1 x1  Warming Rack	2 x1  Thermometer	3 x2  Cooking Grid
4 x1  Handle	5 x1  Lid	6 x4  Air Vent
7 x1  Charcoal Tray	8 x2  Charcoal Tray Lifting Handles	9 x1  Back Leg (Left)
10 x1  Front Leg (Left)	11 x2  Leg CConnecting Part	12 x2  Side Table
13 x1  Firebox	14 x2  Side Support Bar	15 x1  Axel

PARTS LIST

16 **x1**



Bottle Opener

17 **x2**

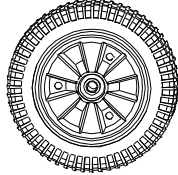

Wheel

18 **x1**



Back Leg (Right)

19 **x1**



Front Leg (Right)

20 **x1**



Bottom Shelf

FIXINGS LIST

A **x50**

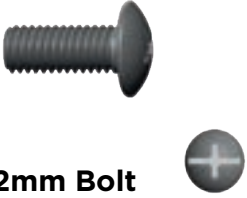

M6 x 12mm Bolt

B **x4**



Nut

C **x2**



Small Cotter Pin

D **x2**



Shoulder Screw

ASSEMBLY GUIDE



STEP 1

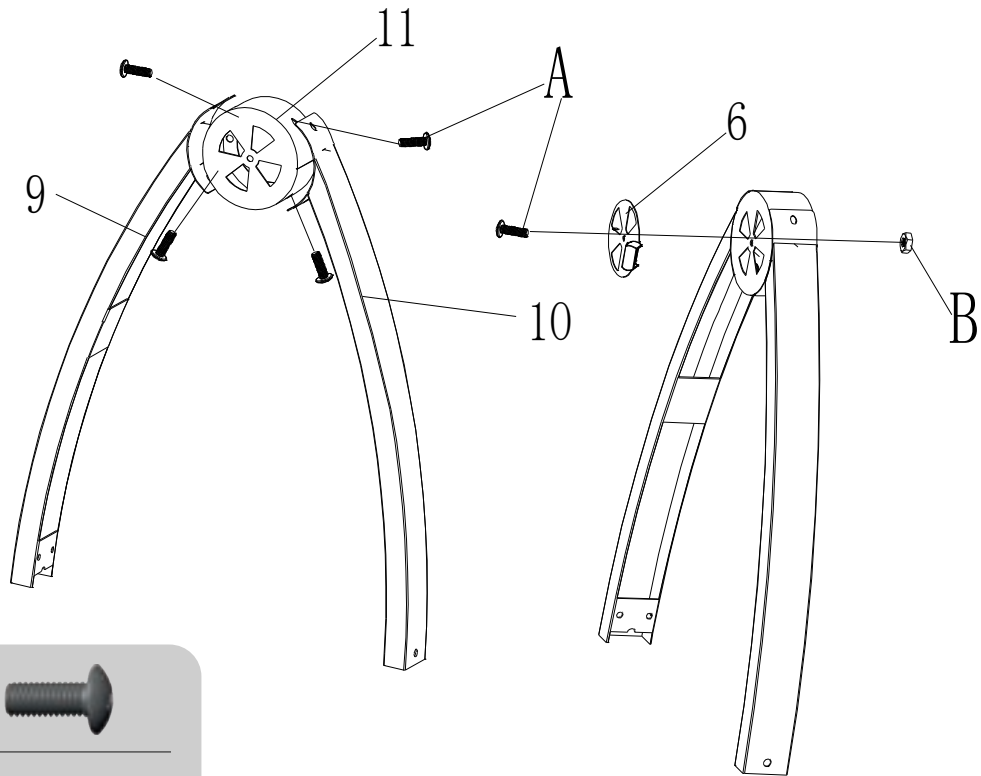

A x5 

B x1 

STEP 2

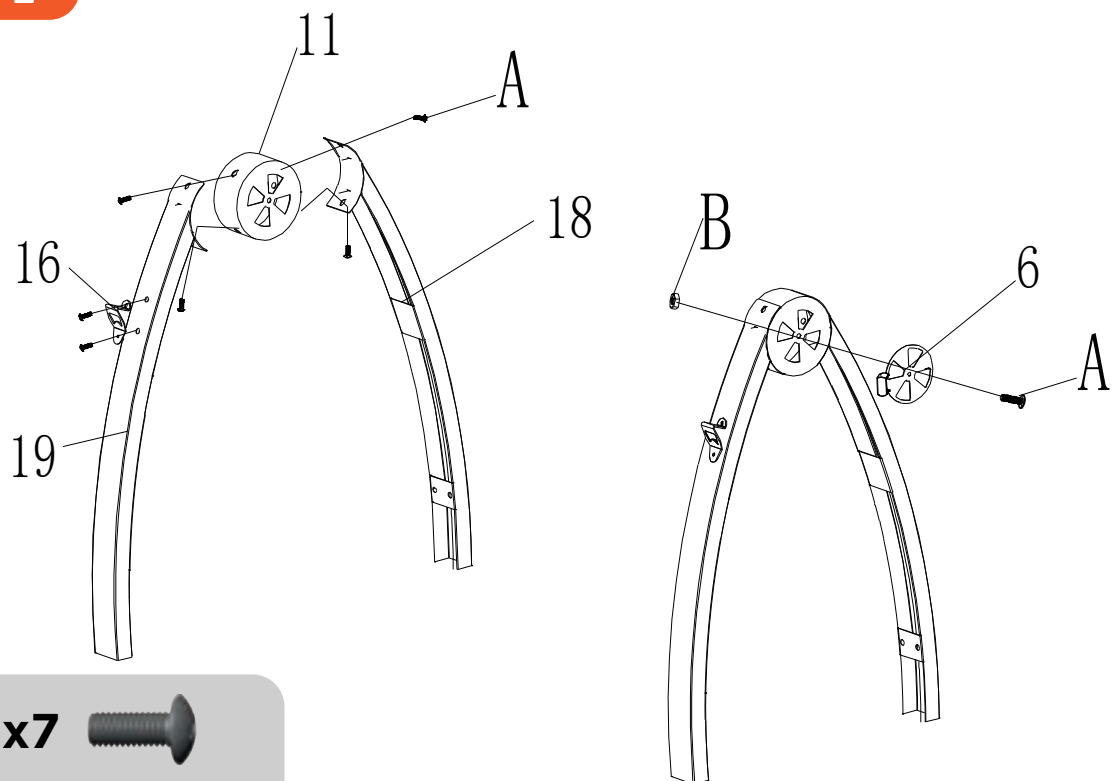

A x7 

B x1 

STEP 3

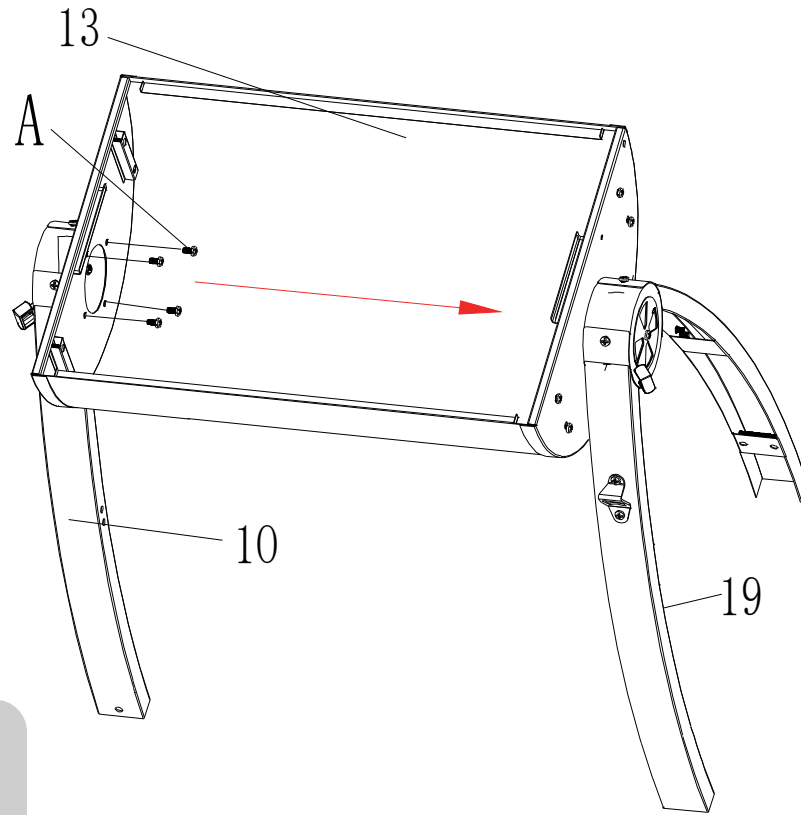

A x8



STEP 4

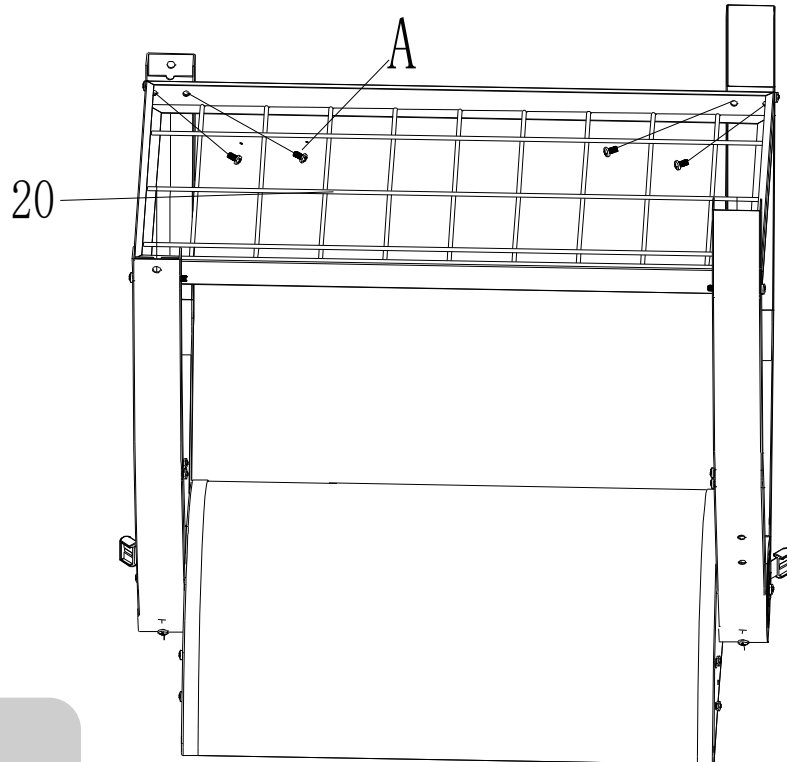

A x8



STEP 5

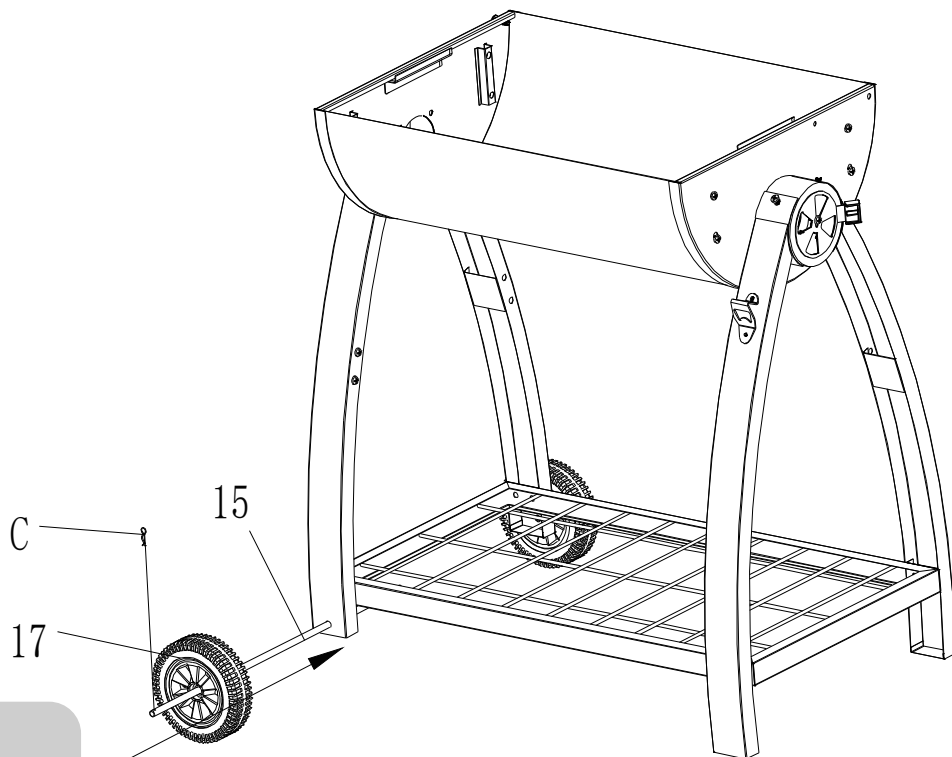

C x2



STEP 6

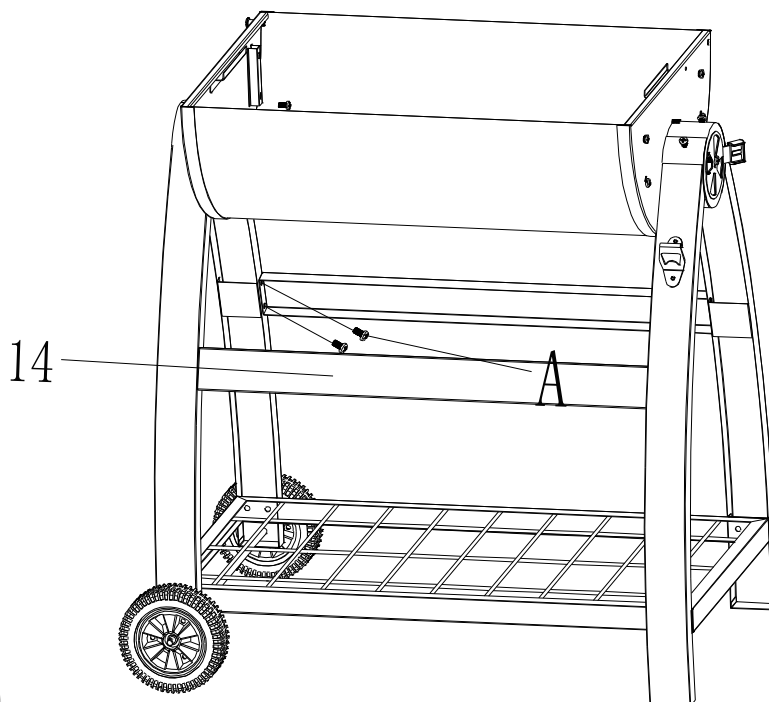

A x8



STEP 7

The screw for fixing the thermometer is pre-installed on the thermometer.

When fitting DO NOT overtighten the thermometer wing nut.

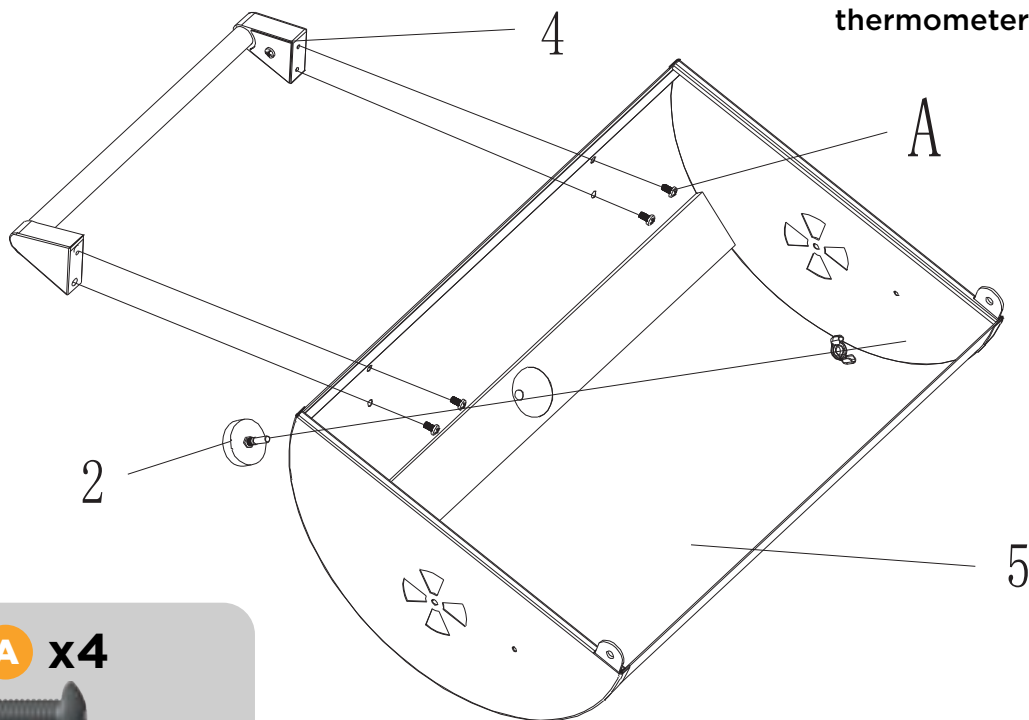

A x4



STEP 8

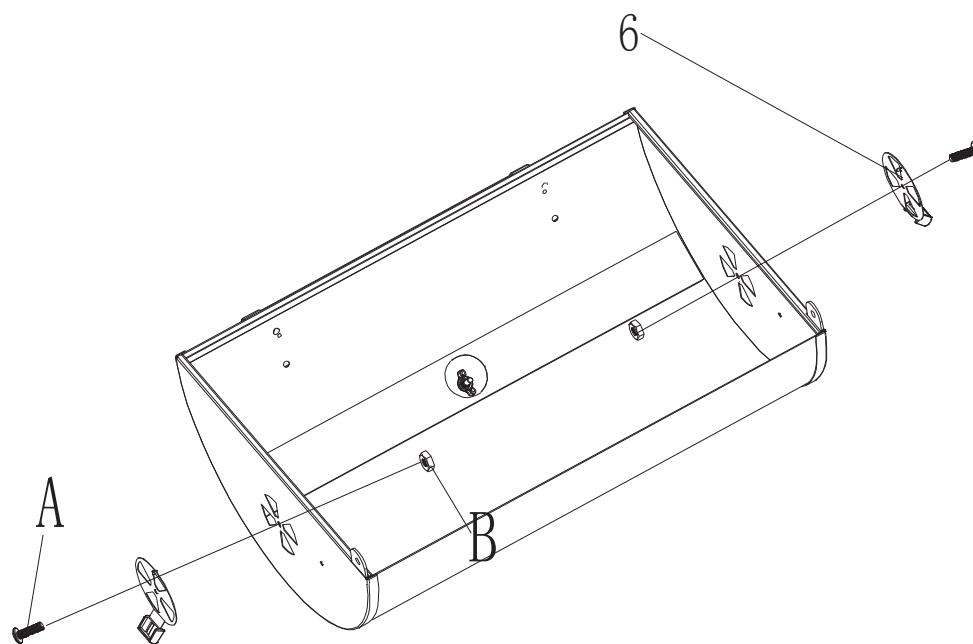

A x2



B x2



STEP 9

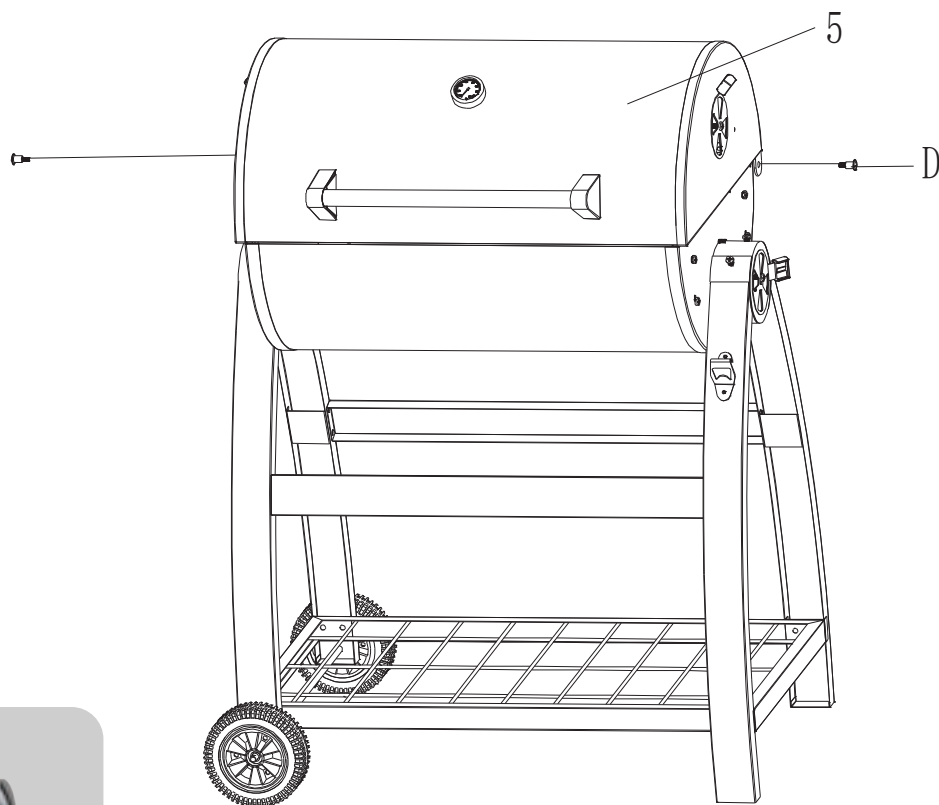

D x2



STEP 10

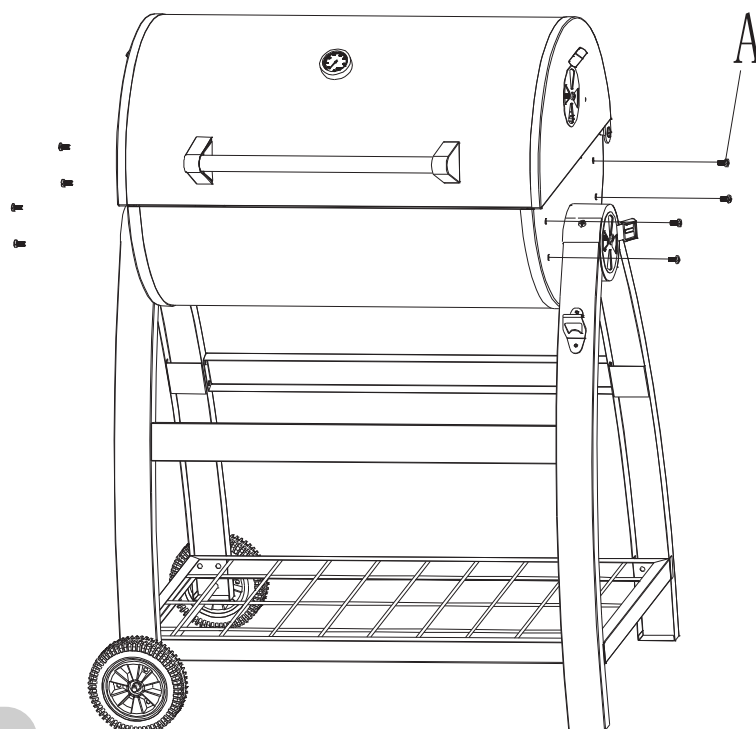

A x8



DO NOT tighten A at this stage. Only tighten after the side tables are added in Step 11.

STEP 11

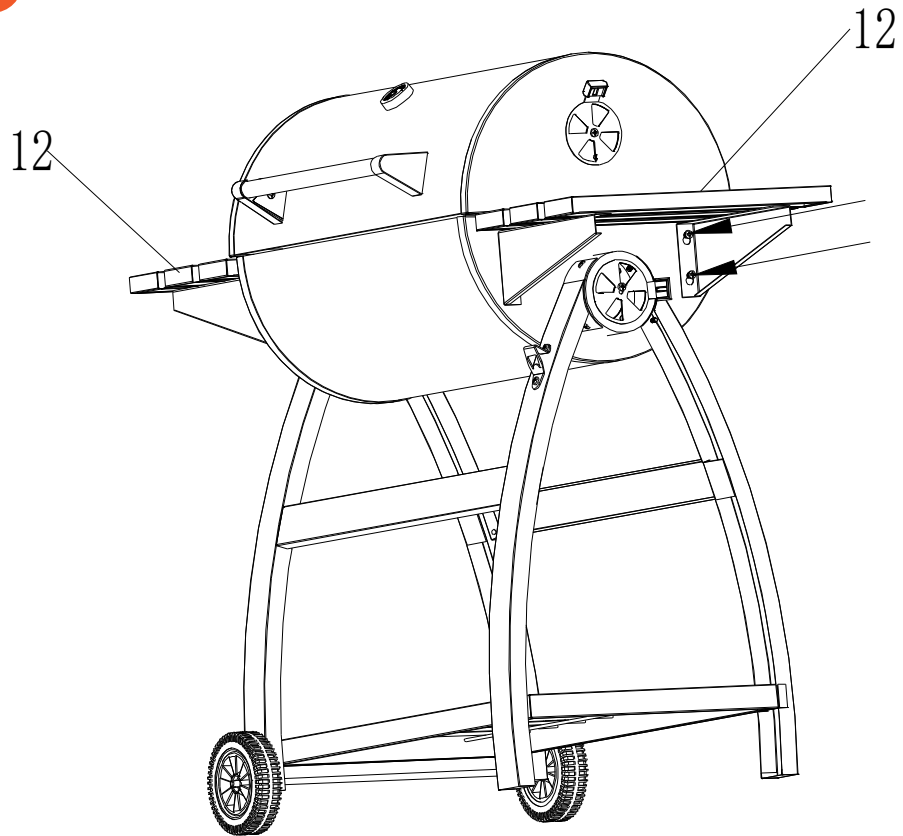

STEP 12

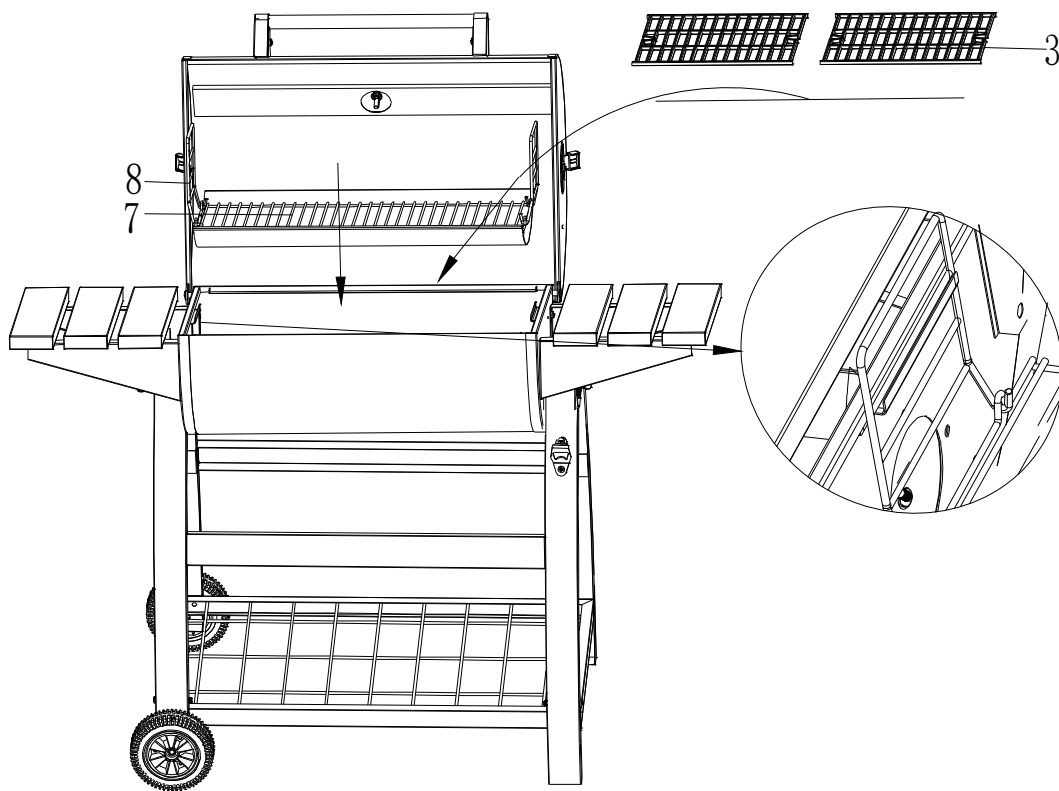

STEP 13

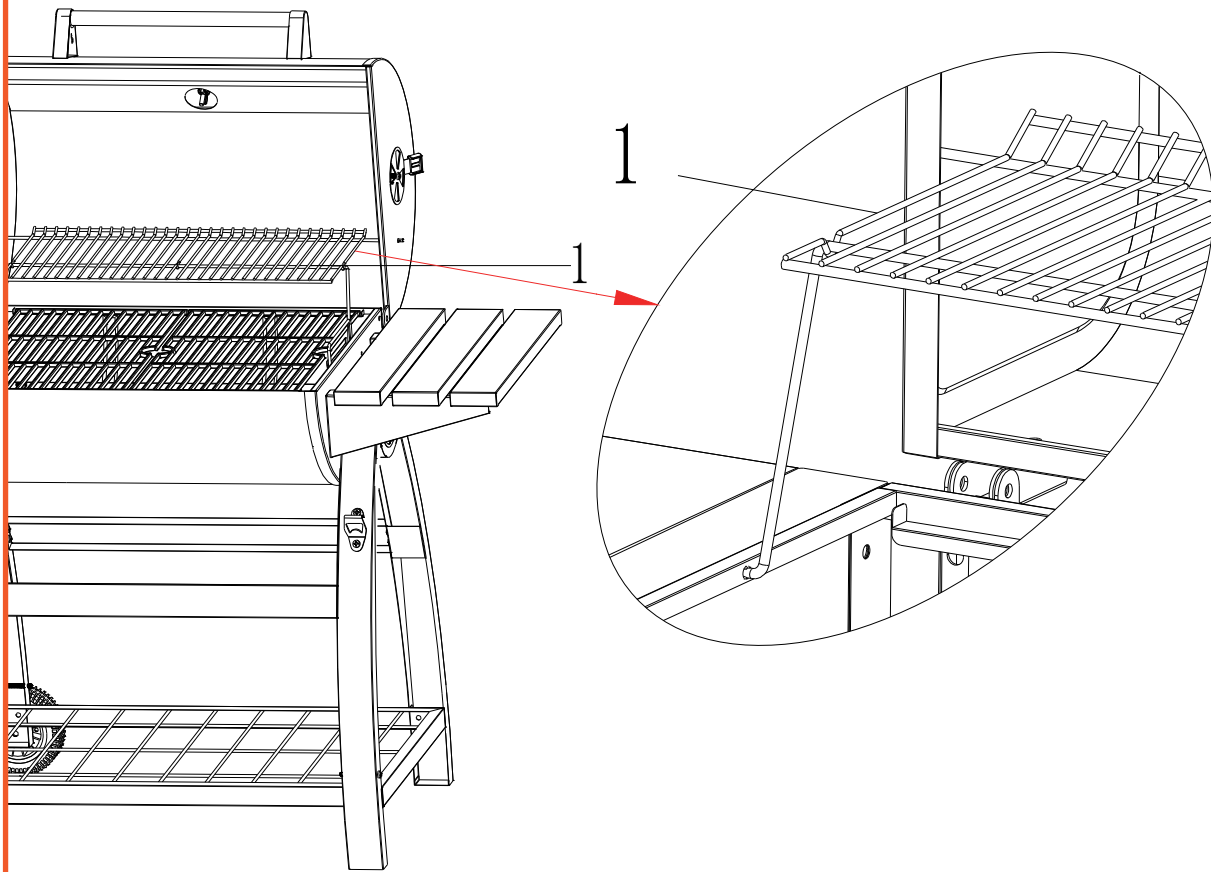

excellent
**EVERY
TIME**



CHARLES
BENTLEY

EST. 1860



Treat your home to something special

Bring comfort, style and relaxation to your home. From elegant outdoor dining to beautiful lounge sets and casual everyday furniture - we help you create your dream indoor & outdoor space.

For inspirational, elegant, and stylish home and garden furniture ideas **visit [CharlesBentley.com](https://www.charlesbentley.com) today.**



ottimo

CharlesBentley.com
Charles Bentley & Son Limited, Loughborough, Leicestershire, LE11 5TP, UK
For EU Enquiries Contact: Authorised Rep Compliance Ltd., Ground Floor,
71 Lower Baggot Street, Dublin, D02 P593, Ireland. www.authorisedrepcompliance.com

excellent
EVERY
TIME