

**NEXT**

Thank you for shopping with us

# NEXT

## CLIFTON FLOOR LAMP

T01204

Assembly Instruction

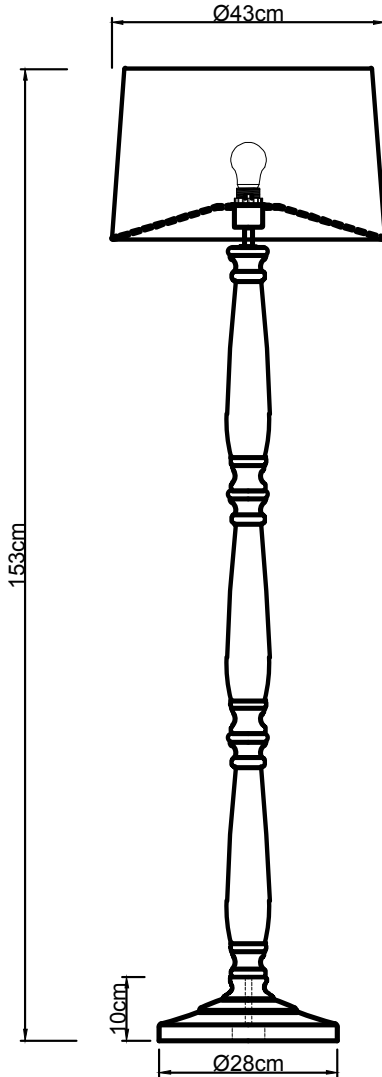

**Actual Product Size**  
 $\text{Ø}430*\text{H}1530\text{mm}$

## Need Help?

With: Assembly instruction  
Missing or damaged parts

**CALL:0333 777 8999**

**IMPORTANT - RETAIN FOR FUTURE REFERENCE**

# NEXT CLIFTON FLOOR LAMP

## T01204

### Assembly Instruction

## BEFORE YOU START

### Warnings

We suggest you retain these instructions for future reference

This light is suitable for indoor use only

### Do's

We suggest you spend a short time reading through this leaflet before you start

When you are ready to start, make sure that you have the right tools and plenty of space

Unwrap all packaging materials and place the components on top of the carton box or on a clean floor to protect it from damage

We recommend that the packaging is used to protect the surfaces during assembly

Carefully check that you have all the parts before beginning assembly

Ensure the product is fully assembled as illustrated and all fixings fully tightened before use. Check fixings regularly to ensure they remain tight

Always switch off the supply before changing light bulbs or cleaning

Allow bulbs to cool down before handling

### Don'ts

Do not position this product in an area, subject to humid or moist conditions.

Do not allow moisture to come into contact with electric parts.

### Time to assemble

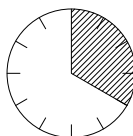

20mins

### Tools required

Scissor for unpacking

### Missing parts

If you are missing any fixtures and fittings for your product please contact our customer service team on 0333 777 8999.

### Cleaning Care

We recommend cleaning with a soft dry cloth. Do not use abrasive materials as these will rub away the protective coating.

### Maintenance

To ensure your safety, if the cable becomes damaged it must be replaced only by a qualified person.

### Safety information

For your safety, please remember the following:

- Always switch off the power supply before changing lightbulbs or cleaning
- Allow bulbs to cool down before handling.

### You can write to us at

Home Customer Services  
Next Retail Ltd,  
Desford Road,  
Leicester,  
LE19 4AT  
or  
Next Retail (Ireland) Ltd,  
13-18 City Quay,  
Dublin 2,  
D02 ED70

To view our full range please visit  
[www.next.co.uk](http://www.next.co.uk)

# NEXT

## CLIFTON FLOOR LAMP

T01204

Assembly Instructions

### GETTING TO KNOW YOUR PRODUCT

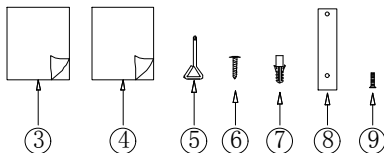
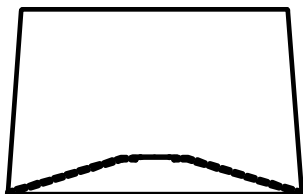
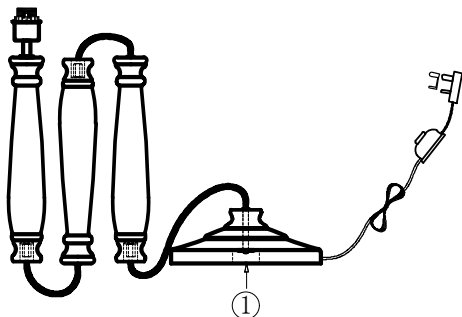

Ref	Description	Specification	Qty	Remark
1	Lamp body		1	Packed in carton
2	Lamp shade	Φ390*Φ430*H270mm	1	Packed in carton
3	Re-package instruction	A4 X 1	1	Packed in fixing pack
4	Assembly instruction	A4 X 2	1	Packed in fixing pack
5	Screw driver		1	Packed in fixing pack
6	Fixing screw	L38mm	1	Packed in fixing pack
7	Rawl plug	L38mm	1	Packed in fixing pack
8	Bracket	L220*W25mm	1	Packed in fixing pack
9	Screw	M5*L20mm	1	Packed in fixing pack



### Assembly Instructions

Unpack the contents of the carton. Lay the contents out on a flat surface giving yourself room to work.

#### Step 1

Screw all the stems together and then screw the stem into the base. Check that they are securely tightened, (See Figure 1) then pull surplus cable through the base of the floor lamp. Remove the shade ring from the lamp holder.

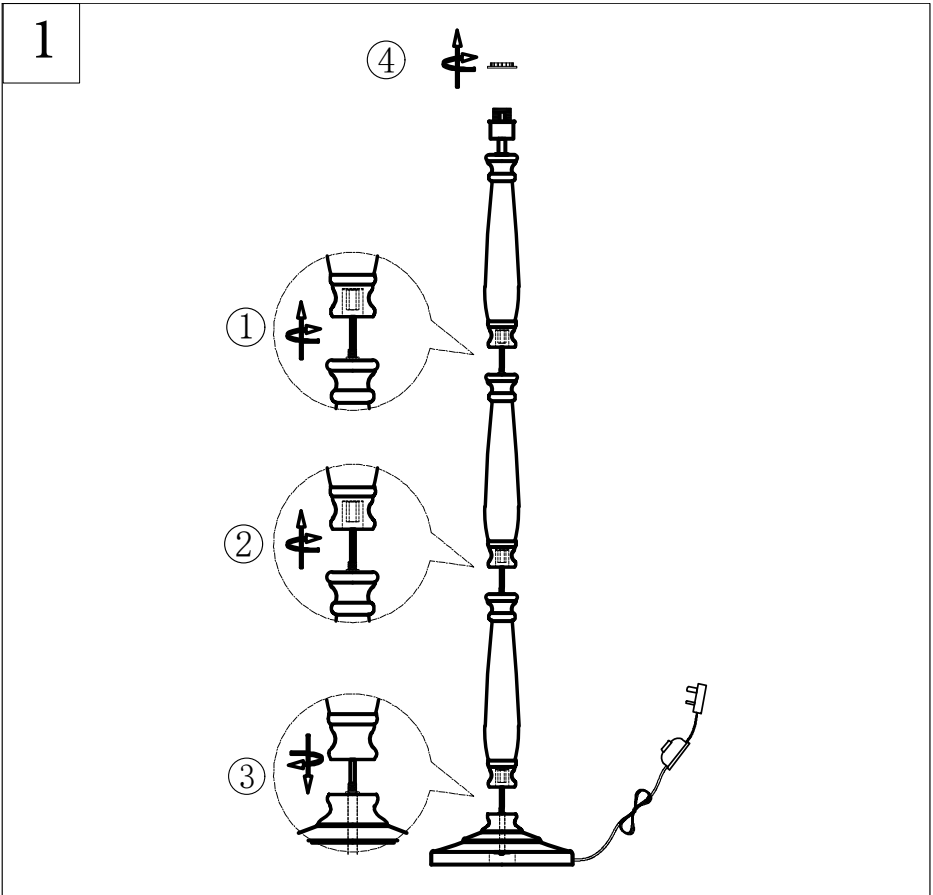

# NEXT CLIFTON FLOOR LAMP

T01204

Assembly Instruction

## Selecting the correct light bulb

Maximum Wattage - 10 Watts

Voltage - 220 - 240Volts

Light bulb type - 10W E27 LED bulb

Do not exceed the maximum wattage as it may cause your light fitting to overheat. Use a soft cloth to handle bulb. (See Figure 2.)

## Attaching shade

Fit the shade onto lamp holder and secure into position with the shade ring (See Figure 2.)

Ensure the shade is securely fixed.

2

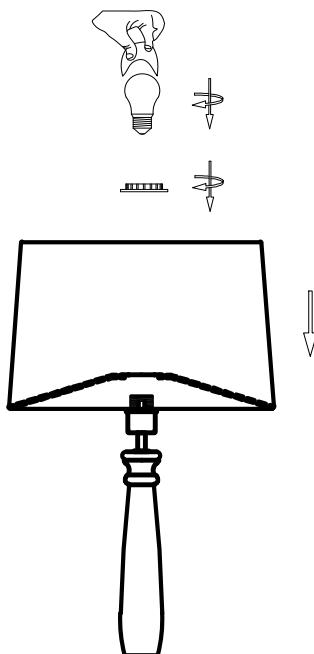

PLEASE NOTE: ENSURE THAT THE AREA DRILLED MUST NOT BE IN CONTACT WITH ANY ELECTRICAL WIRING, WATER OR GAS PIPES. DRILLING WILL LEAVE A PERMANENT MARK ON THE FLOOR.

3) Attach the enclosed bracket to the bottom of the base in the prethreaded hole using the screw ( part no.9) provided. ( See Figure 3)

4) Taking care not to damage any wiring or piping under the floor,drill the floor to the height of the rawl plug. Screw the bracket to the floor using the fixing screw (part no.6) supplied in the accessory pack. Ensure the floor lamp is secured in place. (See Figure 4)

