

BEFORE YOU GET STARTED...

We're confident you'll love your gorgeous new Next furniture. However, it's worth making absolutely certain before you put it all together.

So, let's quickly run through these three steps:

1. COLOUR

Make sure you're happy with the colour
No need to unpack everything, just check the first component.

2. PROTECTIVE PACKAGING

If you're happy, then it's time to get opening! Start by laying everything out on the protective packaging – this will prevent anything getting scratched.

3. PARTS PAGE

Finally, double check you have all the pieces by referencing the parts page of the instructions.

TIPS FOR RETURNS

Not completely happy with the product? No problem. We just need everything back in the original packaging, so follow the steps below and this will ensure a super-smooth returns process and no delay to your refund.

DO



- Check everything is there (the 'parts page' is a handy checklist).
- Pop all the loose fittings and fixtures into the packaging provided or tie them up in a plastic bag.
- Wrap all the big components back up in the original protective packaging.
- Close up the box and seal it securely (don't be afraid to use plenty of tape).

DON'T



- Leave anything assembled - all components should be dismantled and separately packed.
- Put loose fixtures and fittings straight into the box.
- Throw it back in the box carelessly – as it may get damaged.

next
HOME

Then just give us a call on 0333 777 8999 and we'll sort out a pick up time for you.

NEXT

JAUG SGL BRONX CABINET U23709 Assembly instructions

Actual product size
H60.5 x W44 x D13cm

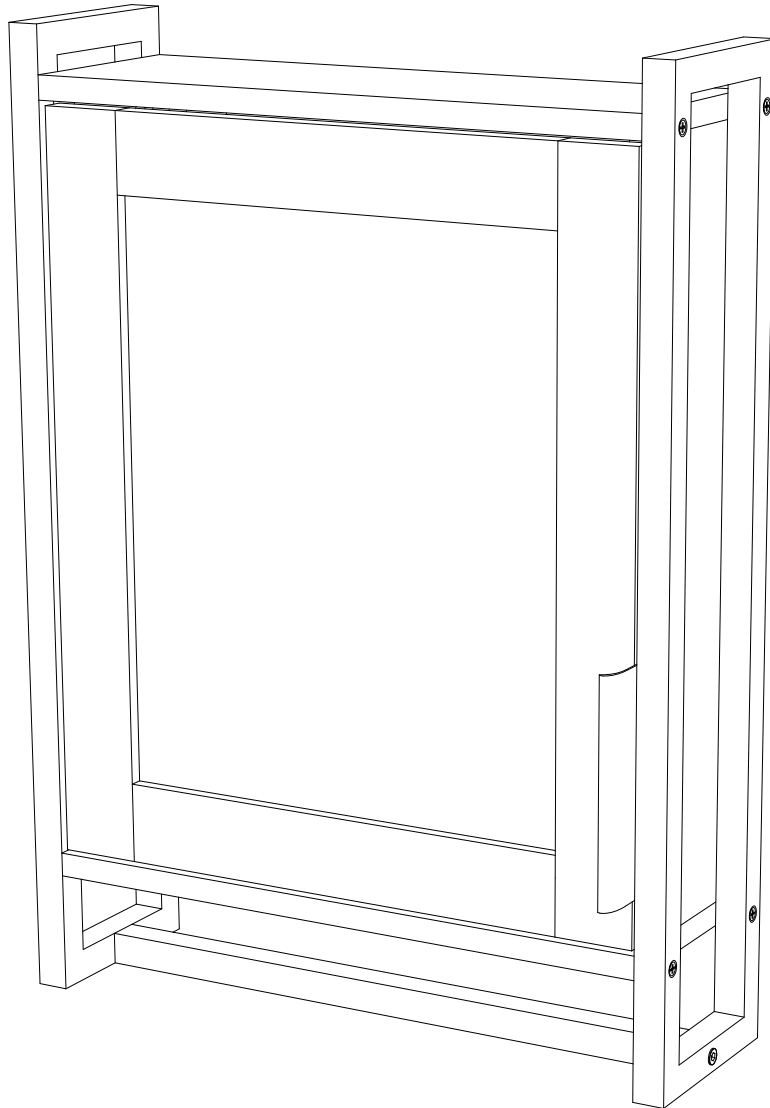

Need Help ?

With: Assembly instruction
Missing or damaged parts

IMPORTANT - RETAIN FOR FUTURE REFERENCE

CALL: 0333 777 8999

TITUS TIGHTENING INSTRUCTIONS

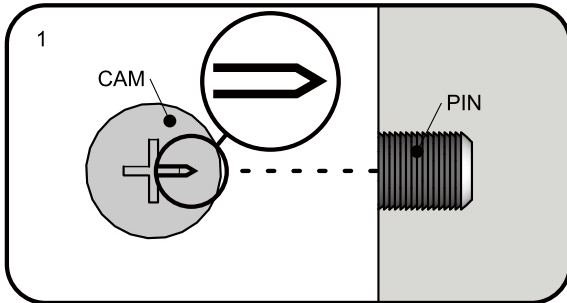

Line up the arrow on the CAM with the PIN.

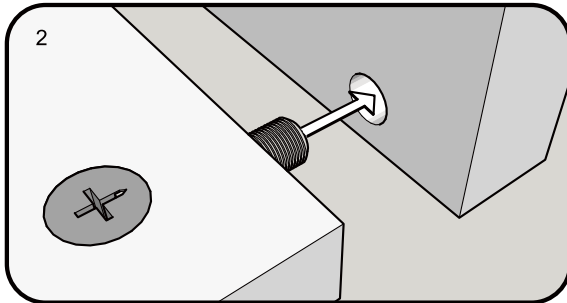

Push the pins into the holes in the panel to be joined.

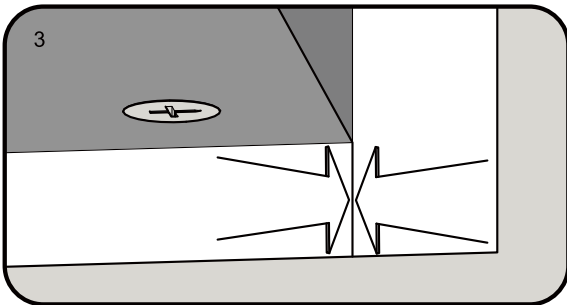

Make sure there is no gap between the panels.

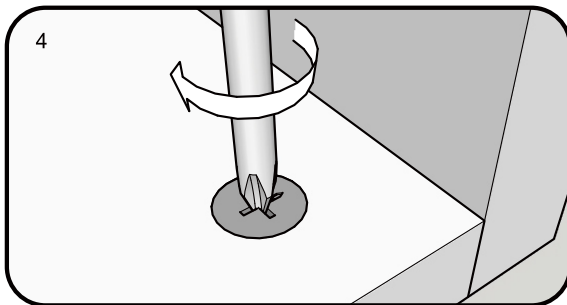

Use a cross-point screwdriver (PH2 or PZ2 is ideal) to tighten the cams and lock the panels together.

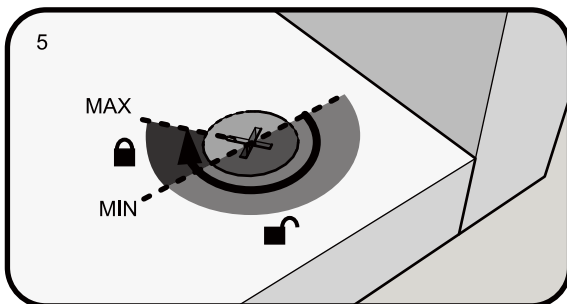

The panels are locked when each cam is turned to between 1/2 and 2/3 of a full turn (Maximum rotation)

BEFORE YOU START

Number of people required to assemble

Two people are required to assemble this item



Time to assemble : 30 minutes



Tools required

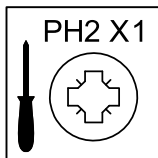

not supplied

- 1 Ensure the bathroom has ample ventilation to prevent moisture build-up.
Ensure there is no standing water on the furniture and wipe away any water.
- 2 Avoid placing the furniture next to the bathtub or shower without a proper shower screen.
Ensure the product is fixed to wall with safety brackets supplied.

Do's

We suggest you spend a short time reading through this leaflet before you start.

When you are ready to start, make sure that you have the right tools and plenty of space.

Unwrap all packaging materials and place the components on a clean surface to protect it from damage, We recommend that the packaging is used to protect the surfaces during assembly.

Carefully check that you have all the parts before beginning assembly.

Due to the size of this product we recommend that it is assembled in the room intended for use.

Ensure the product is fully assembled as illustrated and all fixings fully tightened before use.

Wipe occasionally with a soft cloth slightly dampened with water. Then buff with a dry clean soft cloth.

Don'ts

Do not drag or pull your furniture.

Do not rub or scrub the surface when cleaning.

Do not use silicone based furniture polish. Silicone in furniture polishes can break down the finish.

Never allow any kind of liquid to remain on your furniture.
Absorption can cause wood to warp or finishes to de-laminate.

Do not place hot items (e.g. hot drinks) directly on to the wood surface. Please make sure you use a placemat or coaster.

GETTING TO KNOW YOUR PRODUCT

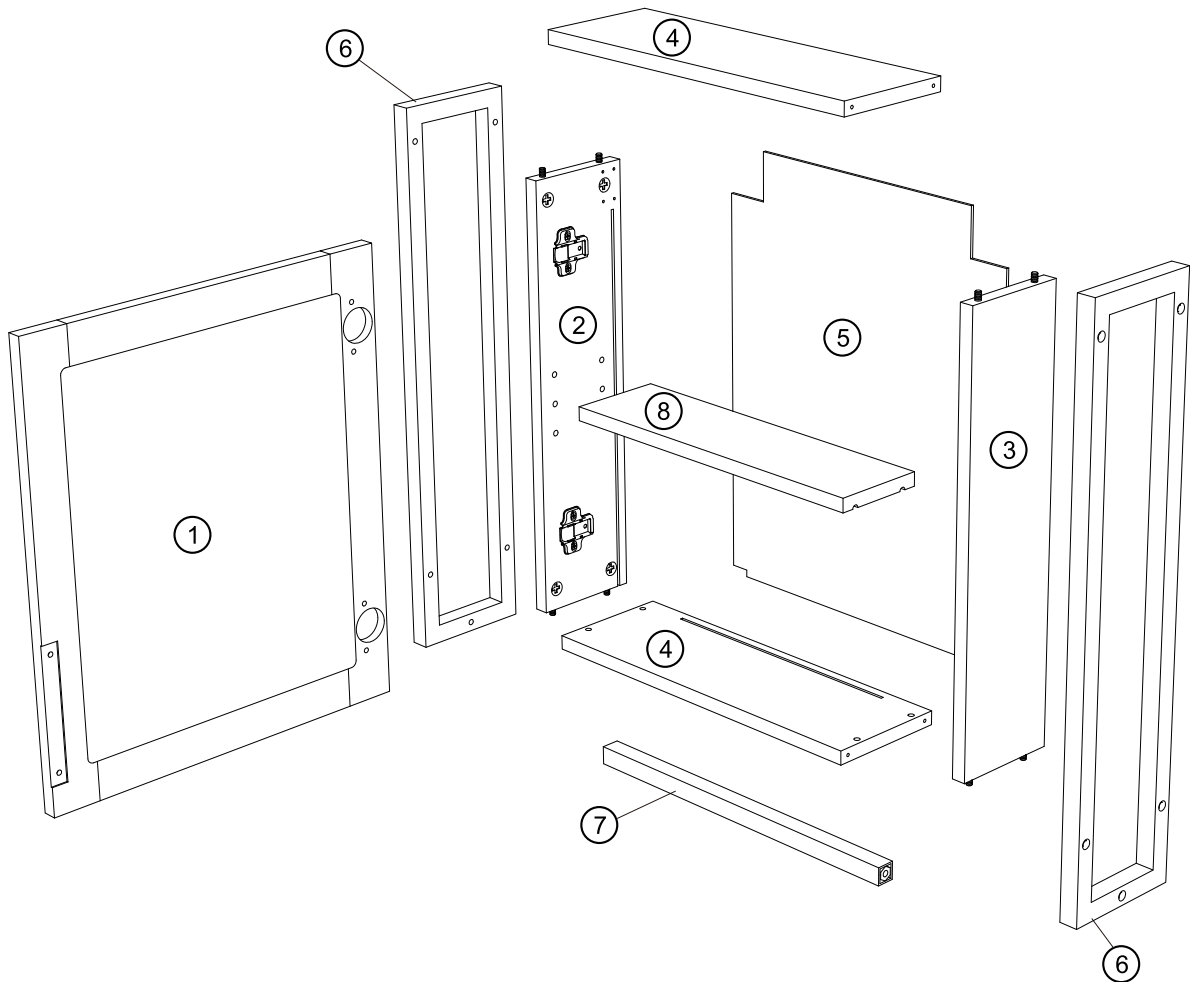

Components supplied. Please use this guide if you require replacement parts.

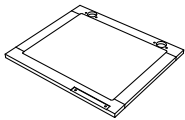
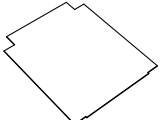
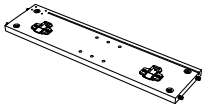
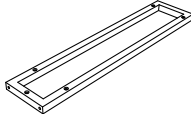
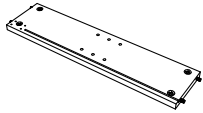
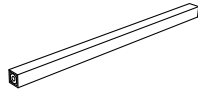
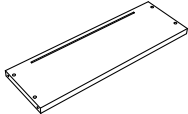
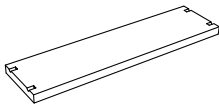





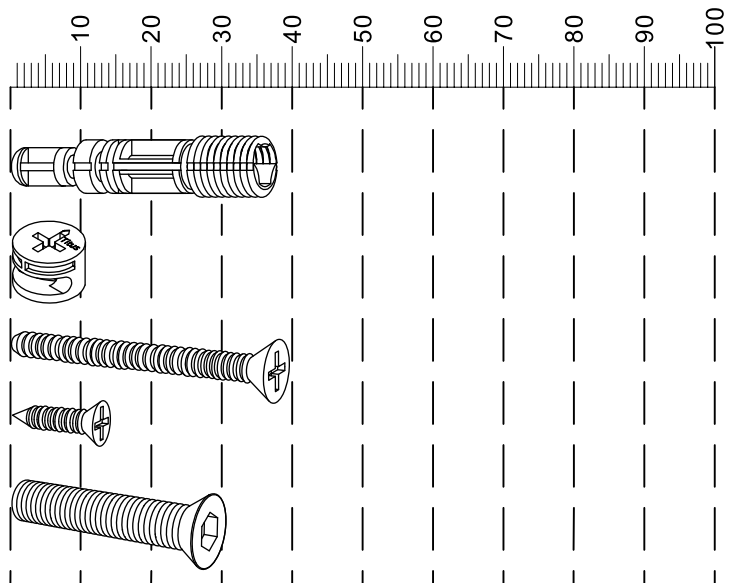

Ref	Dimensions	Visual	Qty	Ctn	Ref	Dimensions	Visual	Qty	Ctn
1	46.4x39.4x1.5cm		1		5	48x38x0.3cm		1	
2	47x11.5x1.5cm		1		6	60.5x13x2cm		2	
3	47x11.5x1.5cm		1		7	40x1.8x1.8cm		1	
4	40x13x1.5cm		2		8	36.5x9.7x1.5cm		1	

Fixtures and fittings supplied (actual size)

Ref	Dimensions	Qty	Spare Qty
A	Ø8 x 38mm	8 pre assembled	1
B	Ø15 x 10mm	8 pre assembled	1
C	Ø4 x 40mm	8	1
D	Ø4 x 14mm	14	2
E	Ø6 x 30mm	2	1





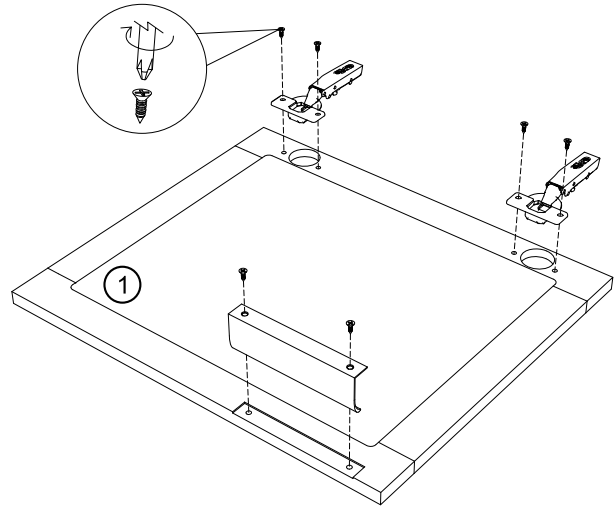

Fixtures and fittings supplied (not to scale)

Ref	Dimensions	Qty	Spare Qty	Visual	Ref	Dimensions	Qty	Spare Qty	Visual
F	120 x 40 x 18mm	1			J	42 x 30 x 46mm	2		
G	N/A	2			K	30 x 25 x 3mm	2		
H	Ø5 x 16mm	4	1		L	4mm	2		
I	43 x 33 x 49mm	2			M	Ø20mm	6	1	

1

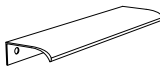

D	Ø4 x 14mm	6	  not supplied
F	120 x 40 x 18mm	1	
G	N/A	2	

2

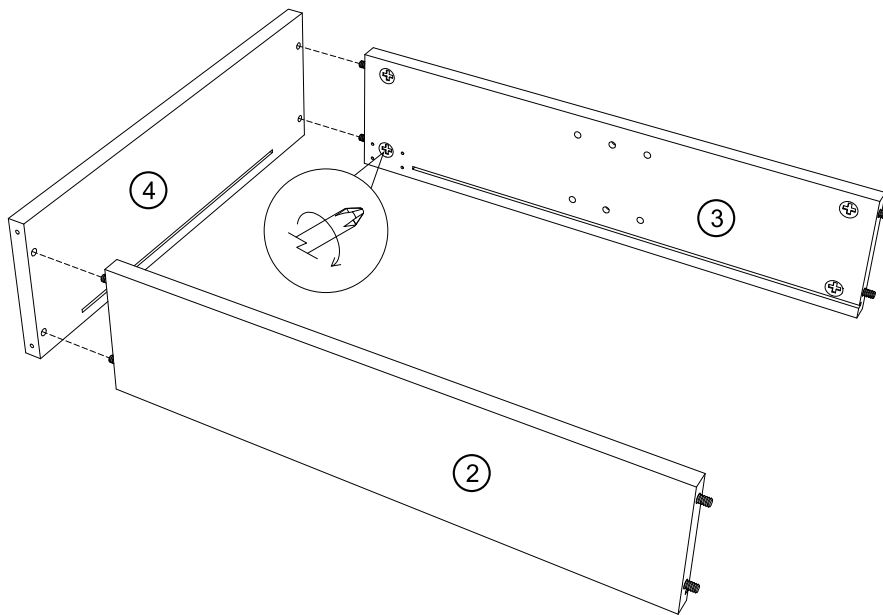

DON'T STOP UNTIL THE 2 O'CLOCK LOCK
TURN THE CAM IN A CLOCKWISE DIRECTION UNTIL THE
ARROW POINTS IN THE POSITIONS SHOWN IN THE
DIAGRAMS BELOW



START

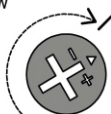

CORRECT
LOCK

PUSH THE TWO PANELS TOGETHER ALLOWING THE
DOWEL TO ALIGN WITH THE HOLE

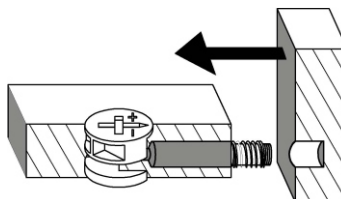

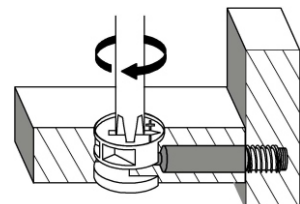

TURN THE CAM IN A CLOCKWISE DIRECTION

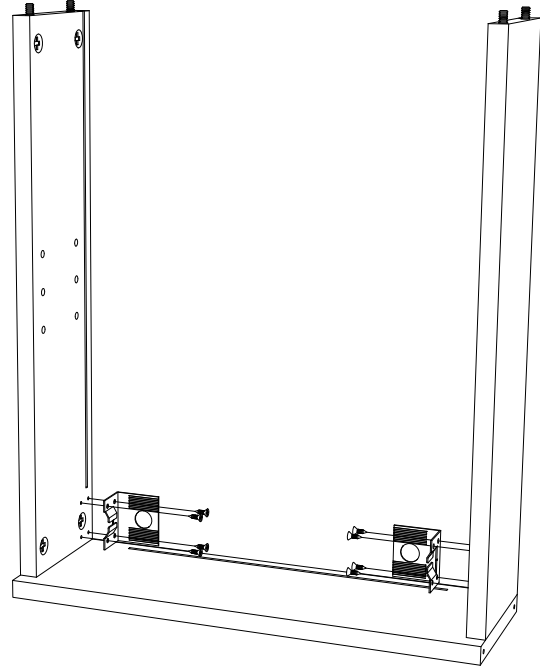
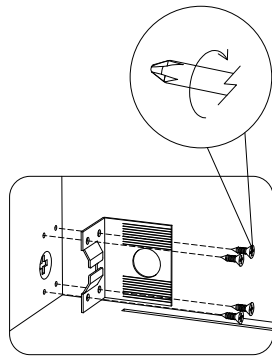

3

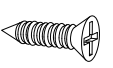

D	Ø4 x 14mm	8	  not supplied
J	42 x 30 x 46mm	2	

4

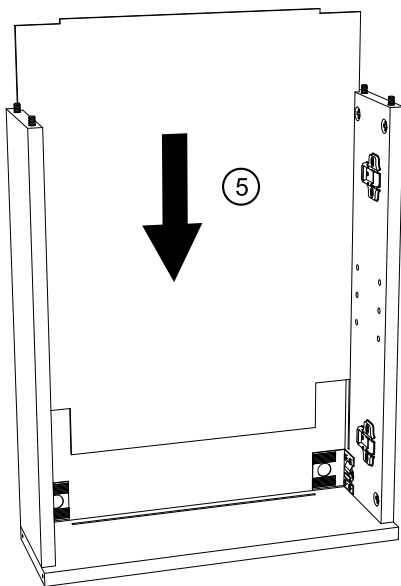

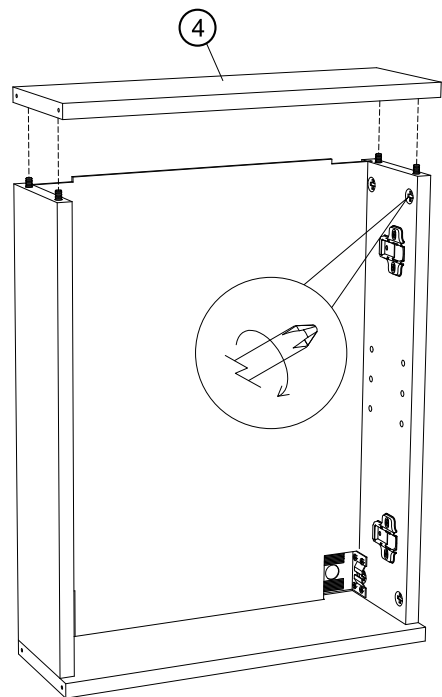

5



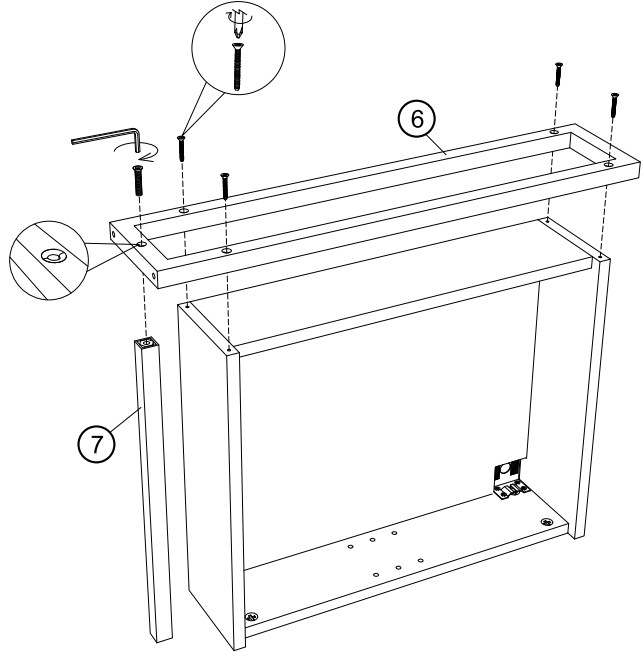

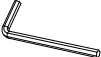

6

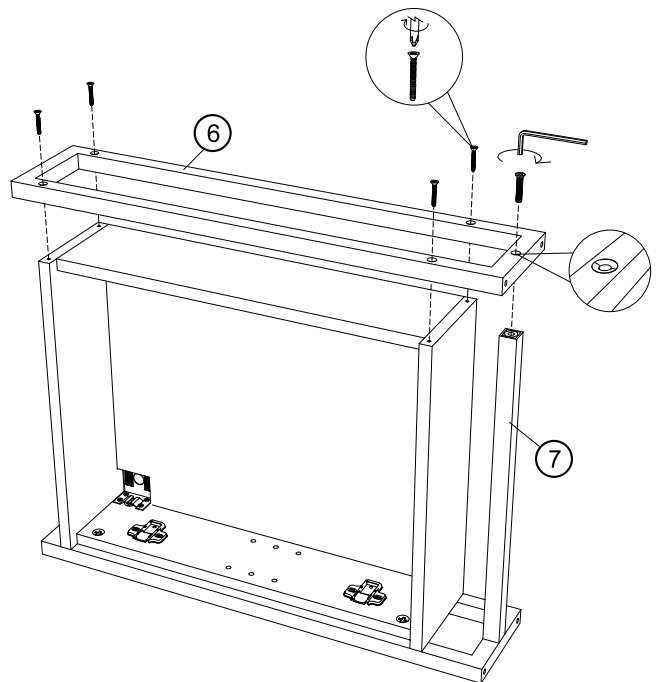

C	Ø4 x 40mm	4	  not supplied
E	Ø6 x 30mm	1	
L	4mm	2	

7



C	Ø4 x 40mm	4	  not supplied
E	Ø6 x 30mm	1	
L	4mm	2	

8

Install hinge

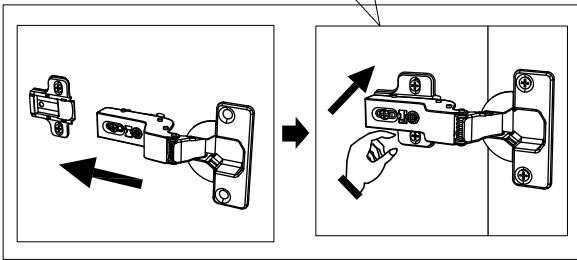
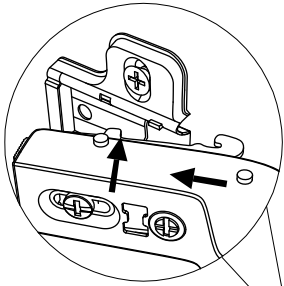

Remove hinge

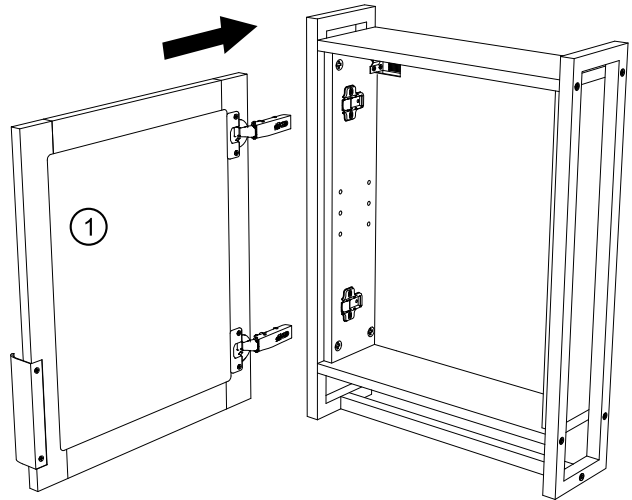
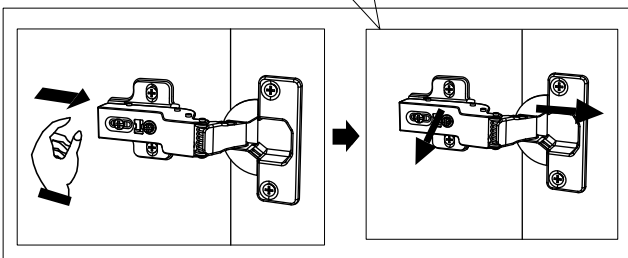
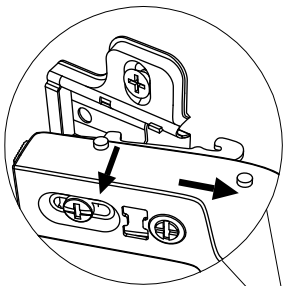

Adjust Hinge Position

LATERAL

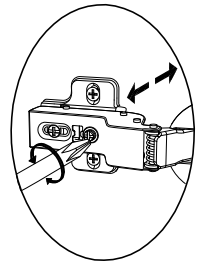

VERTICAL

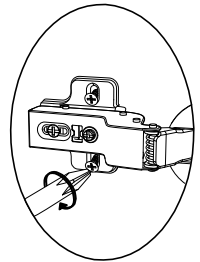
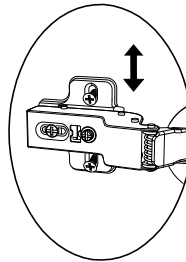
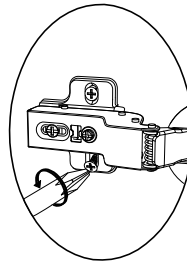

FRONT- TO-BACK

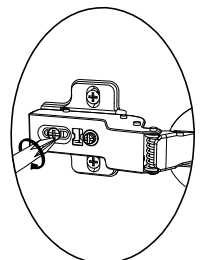
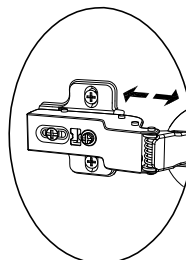
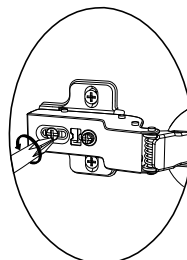

NEXT

JAUG SGL BRONX CABINET U23709 Assembly instructions

9

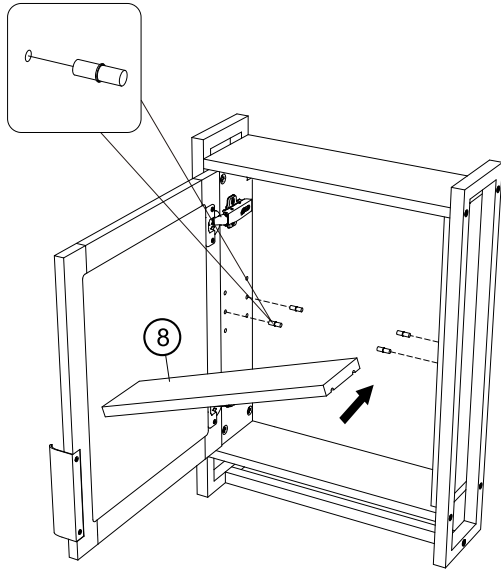

H	Ø5 x 16mm	4	
---	-----------	---	---

10

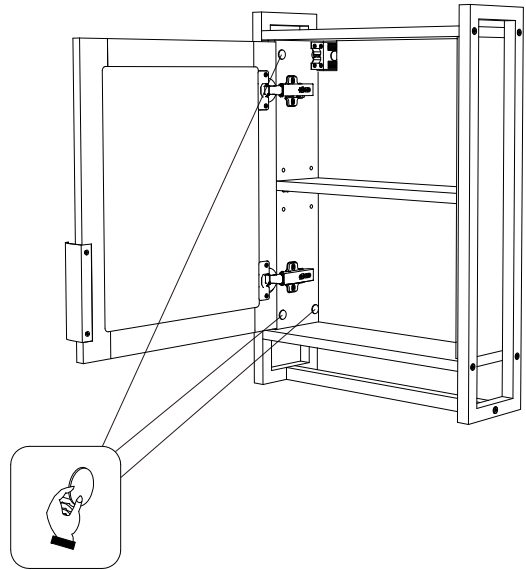

M	Ø20mm	6	
---	-------	---	---

11

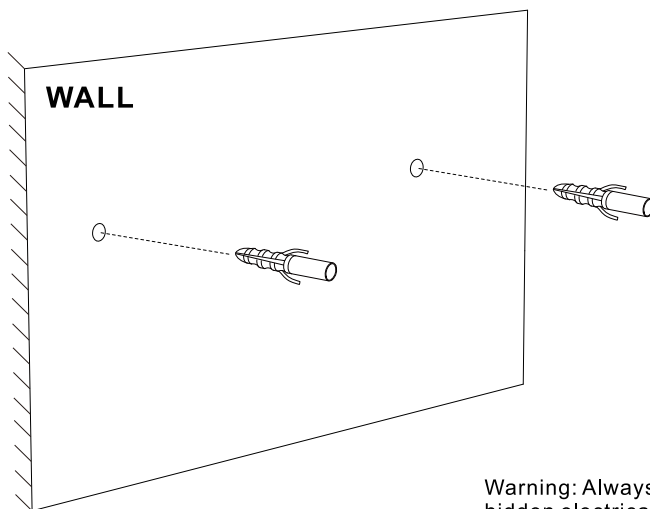

Warning: Always ensure wall area to be drilled is free from hidden electrical wires, water and gas pipes.

12

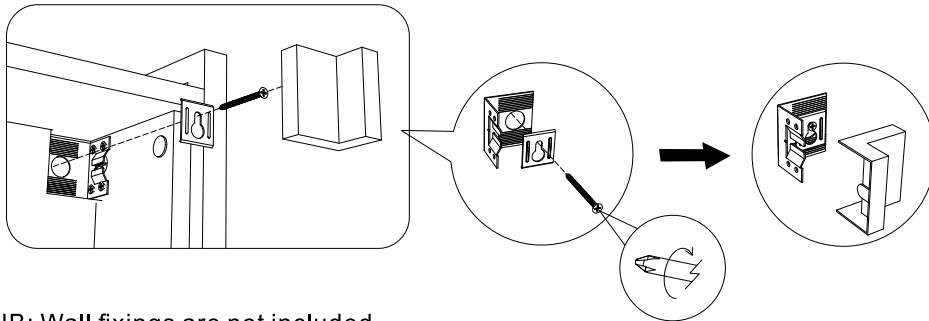
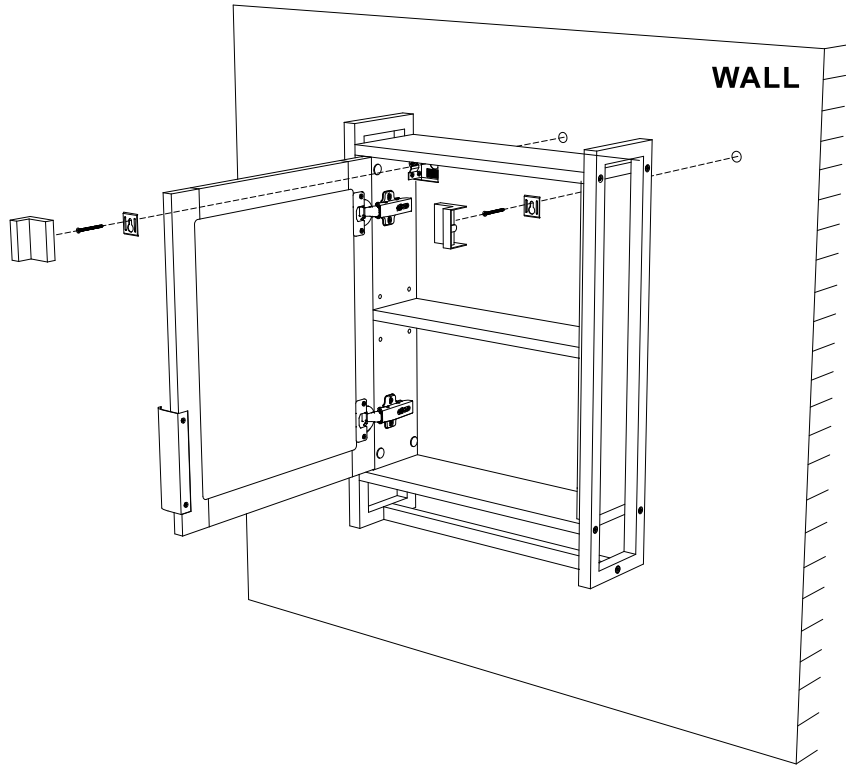

NB: Wall fixings are not included.
Please source suitable fixings for your wall type.
If in doubt please consult a qualified trades person.

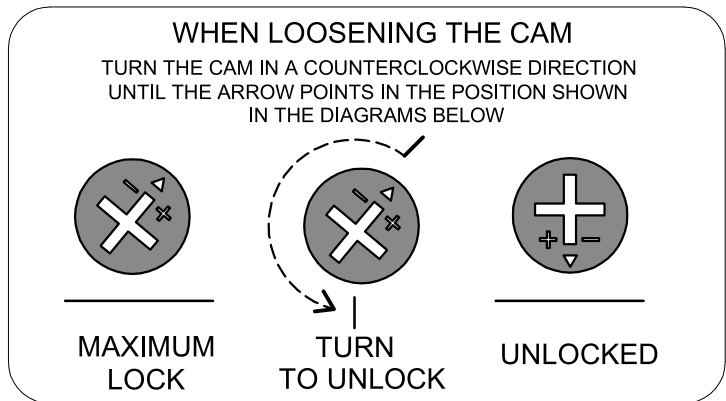

I	43 x 33 x 49mm	2	
K	30 x 25 x 3mm	2	

NEXT

JAUG SGL BRONX CABINET U23709 Assembly instructions

Actual product size
H60.5 x W44 x D13cm

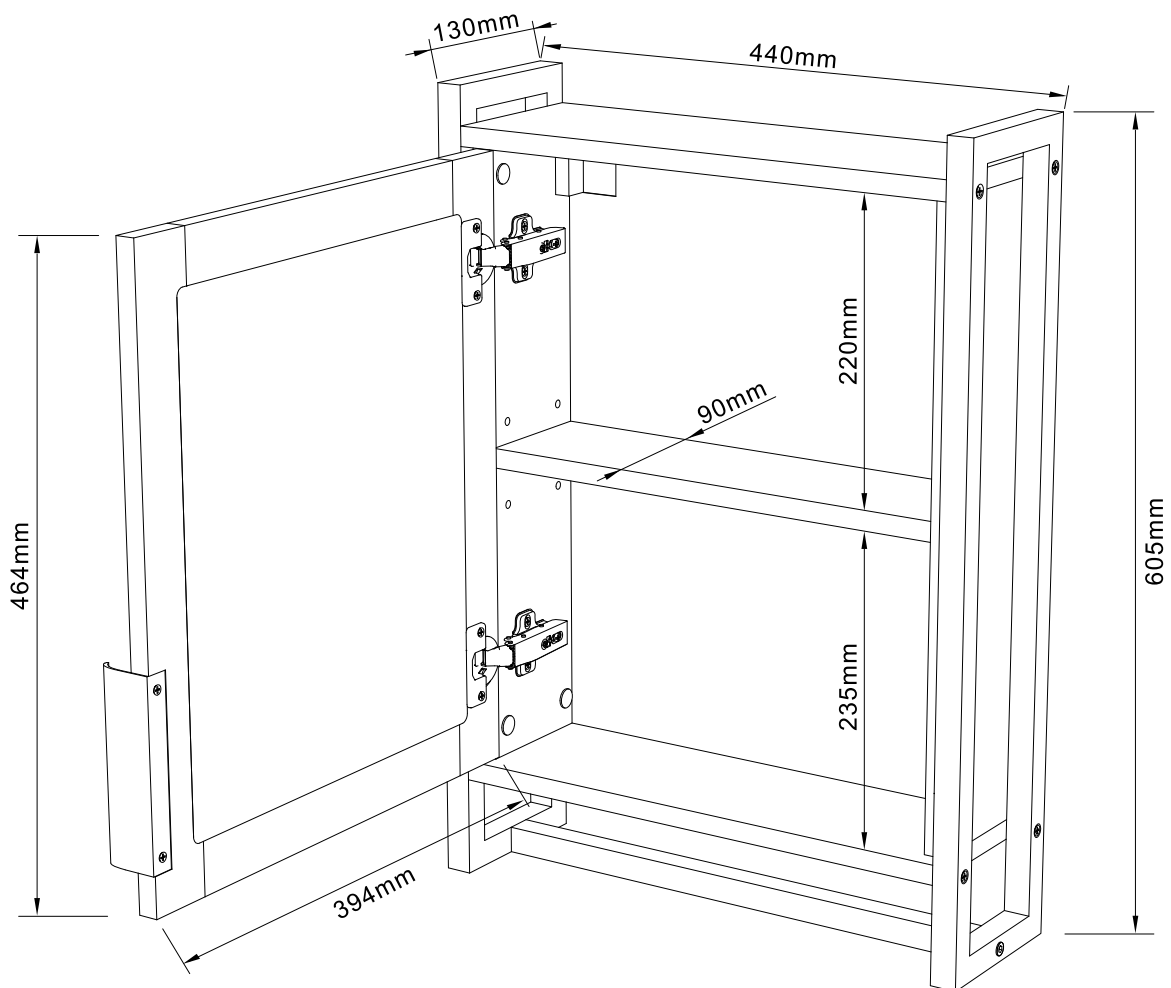

NEXT

JAUG SGL BRONX CABINET
U23709

Warnings

We suggest you retain these instructions for future reference.

Keep fittings out of children's reach and keep children well away from construction area.

This product should only be used on firm level ground.

Please periodically check all fittings and re-tighten as necessary.

Please do not sit or stand on your furniture.

Avoid exposing the furniture to excessive heat or direct sunlight as this can cause deterioration of the colour.

Unwrap all packaging materials and place the components on top of the carton box or on a clean floor to protect it from damage

The product **MUST** be fixed to the wall to avoid toppling risk.

Missing parts

If you are missing any fixtures and fittings for your product. Please contact our customer service team on 0333 777 8999 and they will be happy to arrange for a replacement to be sent to you free of charge.

Home service technicians

If you have a fault with your product, please contact our customer service team on 0333 777 8999. If you have had the product for 28 days or less you may be offered a replacement, refund or for a fully trained home service technician to visit your home to assess the fault and repair the product where possible. If you have had the product for more than 28 days we will send an independent home service technician to review and repair the product where possible and recommend further action.

You can write to us at

Home Customer Services
Next Retail Ltd.
Desford Road,
Leicester,
LE19 4AT

To view our full furniture range please visit www.next.co.uk