

# NOTICE DE MONTAGE

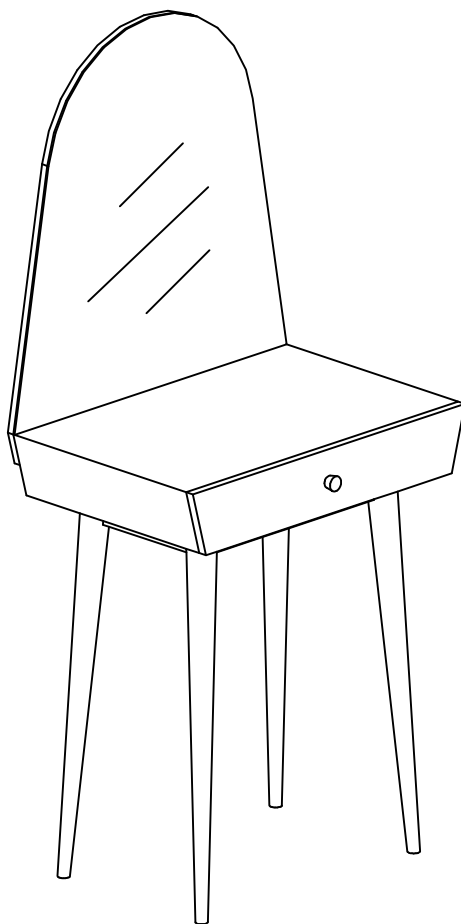

Stock Ref.: 941.1550

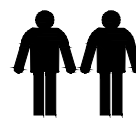

20MIN



- Vor Montage den Inhalt Ihres Päckchens kontrollieren.
- Die Verpackung nicht zerstören, sie wird Ihnen nützlich sein, um die Teile bei der Montage vor Stößen und Kratzern zu schützen.
- Das Möbel dann in der Reihenfolge der Nummerierung zusammenbauen.
- Im Problemfall Ihren Kundendienst anrufen.
- Lüften Sie Ihre Möbel nach dem Aufbau bitte mit geöffneten Möbeltüren und -schubladen in einem gut durchlüfteten Raum. Bitte belüften Sie Ihre Wohnräume regelmäßig.



- Verificare il contenuto della confezione prima del montaggio.
- Non eliminare l'imballo che potrà essere utilizzato per proteggere il prodotto dai danni durante il montaggio.
- Montare l'articolo seguendo l'ordine di numerazione.
- In caso di necessità contattare il nostro servizio post-vendita
- Al ricevimento, areare i vostri mobili, aprendo porte e cassetti, in una stanza ben ventilata. Ricambiare l'aria della stanza regolarmente.







- Check the content of your parcel before assembling.
- Do not throw away the packing which could be very useful to protect the panels from knocks and scratches when assembling.
- Assemble the article following the order of the numbers indicated.
- Should any problems arise, please contact our After Sales Service.
- Upon receipt, place the furniture in a well-ventilated room and leave doors and drawers open to allow the air to circulate. Change the air in your rooms on a regular basis.

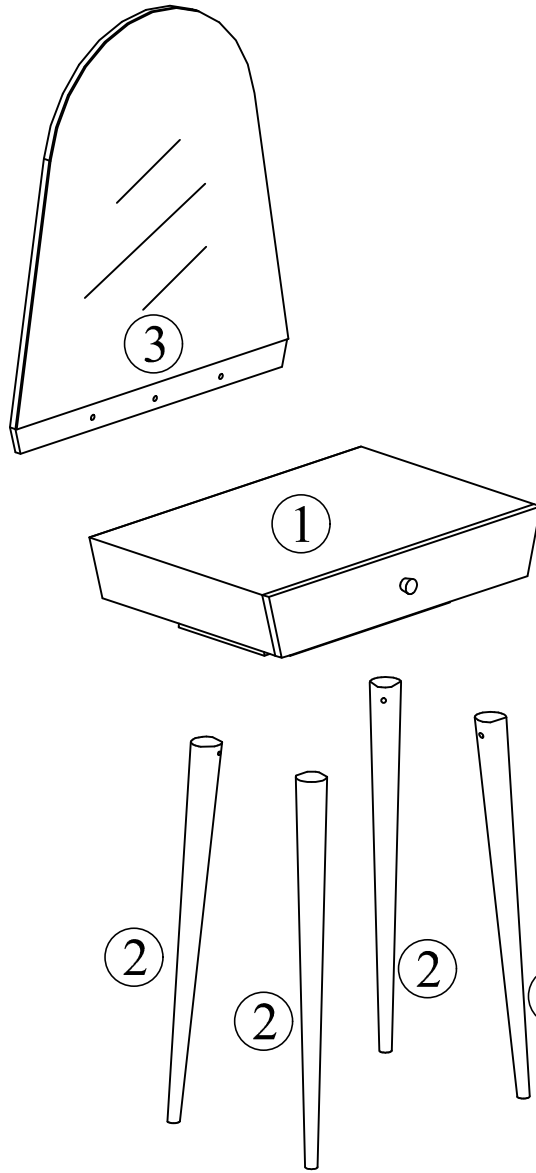





- Contrôlezle contenu de votre colis avant de procéder au montage.
- Ne détériorez pas l'emballage, il vous sera très utile pour protéger les éléments des coups et rayures pendant le montage.
- Assemblez ensuite le meuble en suivant l'ordre défini par la numérotation.
- En cas de problème contactez notre service Après-Vente.
- A réception, aérer vos meubles, portes et tiroirs ouverts, dans une pièce bien ventilée. Renouveler régulièrement l'air de vos pièces.

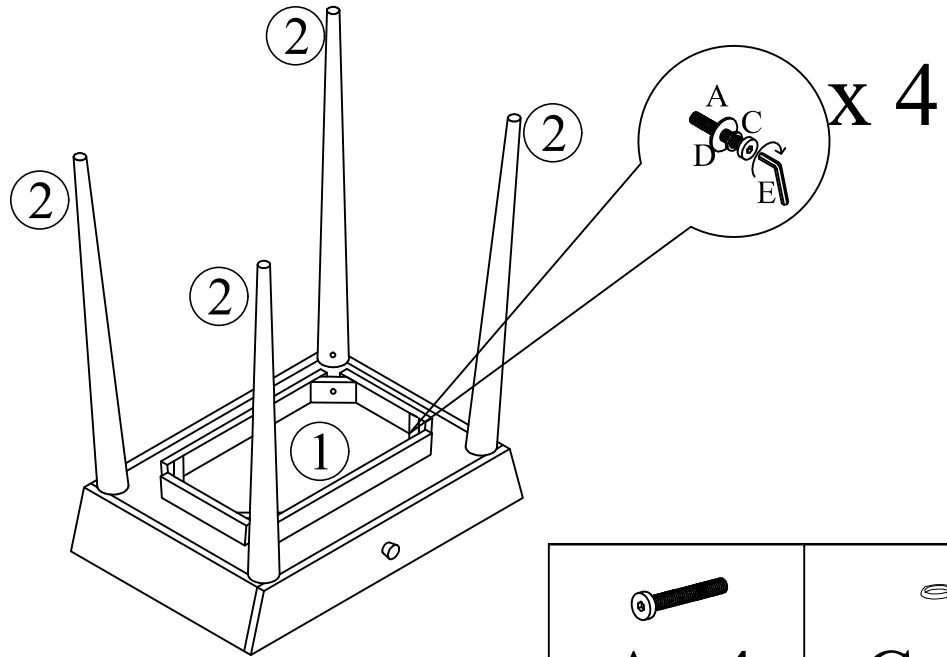

	A x 4	Ø 6x50mm		C x6		E x1
	B x 3	Ø 6x30mm		D x6		





1

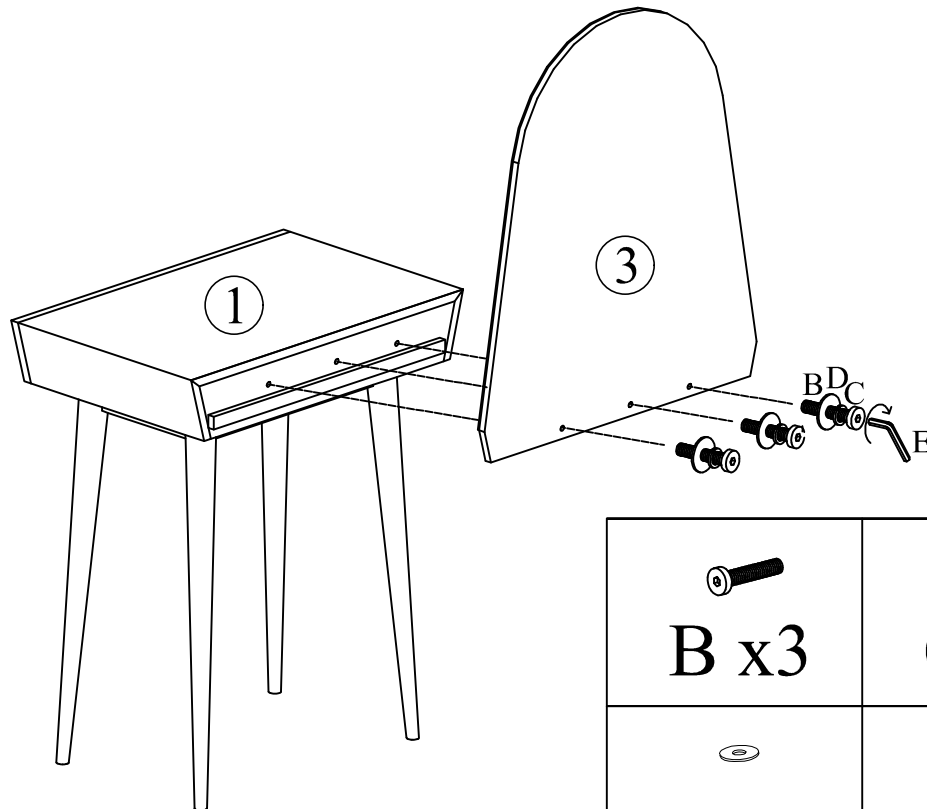

	
A x4	C x4
	
D x4	E x1

2



	
B x3	C x3
	
D x3	E x1