

MOYEN - MEDIUM
MITTEL - MEDIO

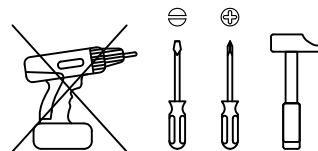

2



FR / Pour toute demande de SAV, contactez-nous via l'espace dédié « demande de SAV » accessible dans votre suivi de commandes sur notre site www.laredoute.fr, ou nous contacter au 0 969 323 515.
UK / If you need information about your product, email helpline@laredoute.co.uk or call: 033 0303 0199.

CH / Wenn Sie Fragen zu Ihrem Produkt, email: info@laredoute.ch oder anrufen: FR/IT: 0848 848 505, DE: 0848 848 505.

BE / Si vous avez des questions sur votre produit, email: serviceclient@laredoute.be ou appeler: 056 85 15 15 - Als u vragen over uw product, email: klantendienst@laredoute.be of bel: 056 85 15 00.

ES / Si tiene alguna pregunta acerca de su producto, email: contacto@laredoute.es o llamar: 902 33 00 33.

PT / Se você tiver dúvidas sobre o seu produto, email: contacto@laredoute.pt ou chamar: 707201010.

SE / Om du har frågor om din produkt, email: service@laredoute.se eller ring: 033 - 48 20 00.

NW / Hvis du trenger informasjon om produktet, email: service@laredoute.no eller telefon: 66-89-15-00.

IT / Se hai delle domande sul tuo articolo, ecco la mail via nuestro website.

PL / Jeśli mają Państwo pytania dotyczące produktu, prosimy pisać na numer telefonu: 32 225 28 28.

RU / Если Вам необходима дополнительная информация о товаре, свяжитесь с нами по телефонам 8 800 555 75 35 / 8 (495) 795 30 30, email: info@laredoute.ru.

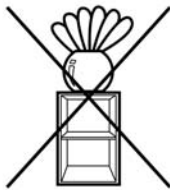
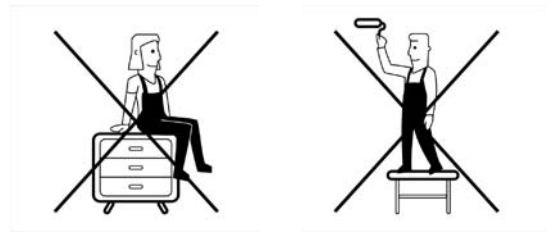
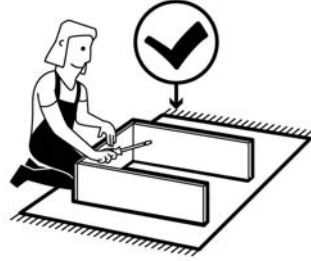

ATTENTION / WARNING / ACHTUNG / WAARSCHUWING / ADVERTENCIA / AVVERTENZA / IMPORTANTE

Français

ATTENTION

Risque de blessures graves ou mortelles en cas de basculement du meuble.

TOUJOURS fixer ce meuble au mur à l'aide des fixations antibasculement. Pour encore réduire les risques de blessures graves ou mortelles dus au basculement du meuble :

- Placer les objets les plus lourds dans le tiroir du bas.
- Ne jamais laisser les enfants grimper ou s'accrocher aux tiroirs.

English

WARNING

Serious or fatal crushing injuries can occur from furniture tip-over. ALWAYS secure this furniture to the wall using tip-over restraints. To further reduce the risk of serious injury and death from tip-overs:

- Place heaviest items in the lower drawer.
- Do not set TVs or other heavy objects on top of this product.
- Never let children climb or hang on drawers.

Deutsch

ACHTUNG

Umfallende Möbelstücke können lebensgefährlich sein. Um diesem Risiko zu entgehen, muss das Möbel UNBEDINGT mit dem beigegepackten Kippschutz an der Wand befestigt werden. Um das Risiko schwerer oder gar tödlicher Verletzungen durch umkippende Möbelstück weiter zu mindern, bitte Folgendes beachten:

- schwere Gegenstände immer in Bodennähe aufbewahren.
- Fernsehgeräte oder andere schwere Geräte niemals auf das Produkt stellen.
- Kindern niemals erlauben, auf Schubladen, Türen und Regale zu klettern oder sich daranzuhängen.

Nederlands

WAARSCHUWING

Opbergmeubels die omvallen kunnen ernstig of levensbedreigend letsel veroorzaken.

Om dat te voorkomen dient het meubel ALTIJD met het meegeleverde kantelbeslag aan de muur te worden bevestigd. Om het risico op kantelende voorwerpen en daarmee ernstig letsel of dodelijke ongevallen nog verder te vermijden, is het verstandig hiermee rekening te houden:

- Plaats zware voorwerpen altijd helemaal onderin.
- Zet nooit een tv of andere zware voorwerpen op het meubel.
- Sta niet toe dat kinderen op lades, deuren of planken klimmen of eraan gaan hangen.

Español

ADVERTENCIA

Si el mueble vuelca, puede provocar lesiones muy graves e incluso mortales. Fija SIEMPRE este mueble a la pared utilizando los accesorios antivuelco. Para reducir aún más el riesgo de lesiones graves o incluso mortales causadas por el vuelco del mueble:

- Guarda los objetos más pesados en el cajón inferior.
- No pongas un TV u otros objetos pesados encima de este producto.
- Evita que los niños suban encima del mueble o se cuelguen de los cajones, las puertas o los estantes.

Italiano

AVVERTENZA

Se il mobile si ribalta può causare lesioni da schiacciamento gravi o mortali.

Fissa SEMPRE questo mobile alla parete usando i componenti di sicurezza.

Per ridurre ulteriormente il rischio di lesioni gravi o mortali causate dal ribaltamento:

- Metti gli oggetti più pesanti nel cassetto inferiore.
- Non collocare la TV o altri oggetti pesanti sopra questo prodotto.
- Evita che i bambini si appendano o si arrampichino sui cassetti, sulle ante o sui ripiani.

Portugues

IMPORTANTE

A queda de móveis pode provocar ferimentos graves ou fatais.

Fixe SEMPRE este móvel à parede com acessórios de fixação.

Para reduzir o risco de ferimentos graves ou morte pela queda de móveis:

- Coloque os itens mais pesados nas gavetas mais baixas.
- Não coloque televisões ou outros objetos pesados em cima deste artigo.
- Nunca permita que as crianças subam ou se pendurem nas gavetas, portas e prateleiras.

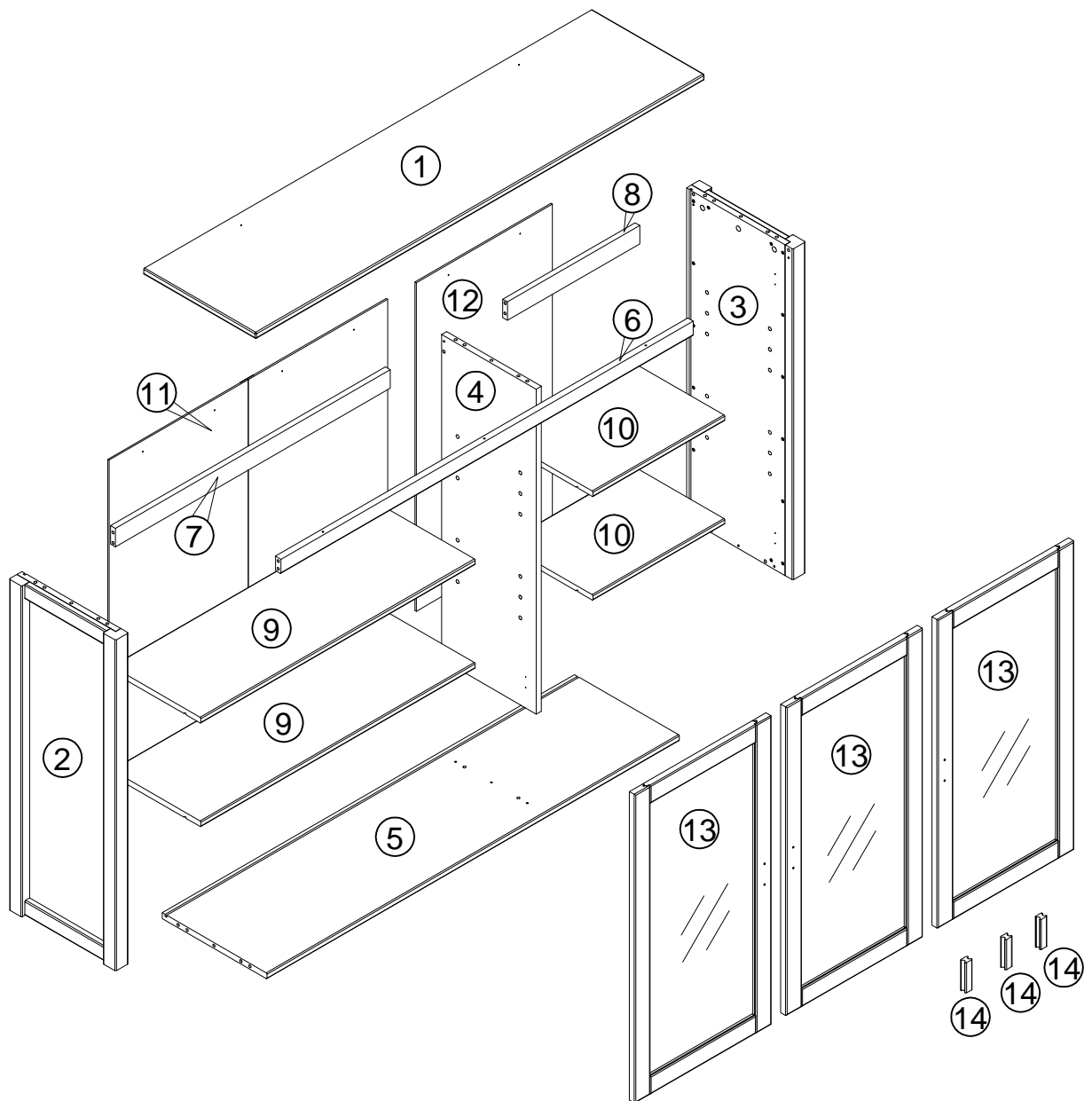



Ⓐ x 24  D15

Ⓑ x 24  D15

Ⓒ x 18  D8 x 30

Ⓓ x 3 

Ⓔ x 6 

Ⓕ x 3 

Ⓖ x 40  M3.5 x 15

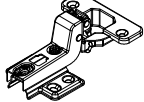
Ⓗ x 6 

Ⓘ x 16 

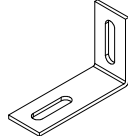
Ⓙ x 2 

Ⓚ x 2  M3.5 x 15

Ⓛ x 6 

Ⓜ x 6  M3 x 20

Ⓝ x 2 

Ⓞ x 3  M3.5 x 35

Ⓟ x 10  M3 x 15

Ⓠ x 9  M3.5 x 15

Ⓡ x 2 

Ⓢ x 4 

1

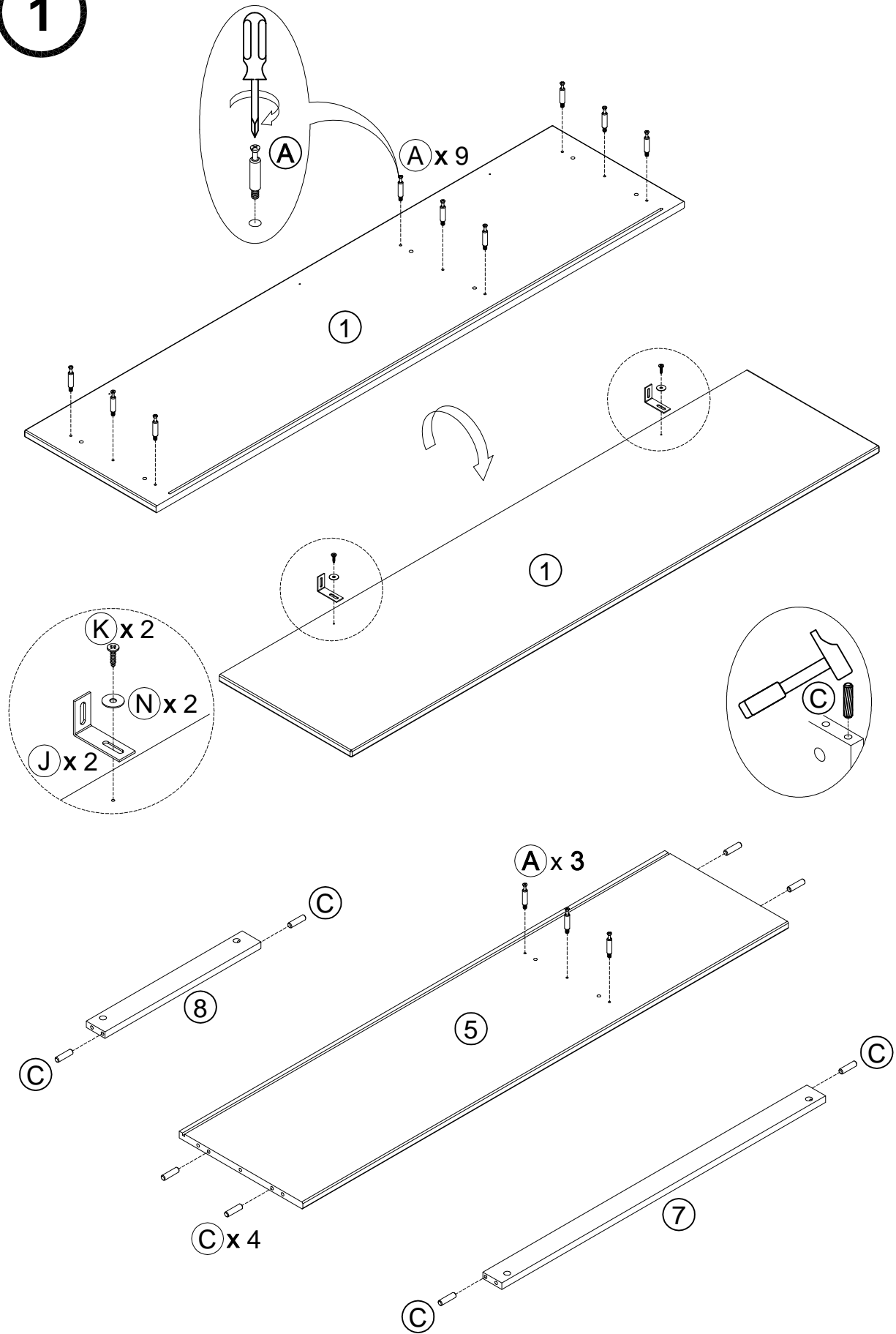

2

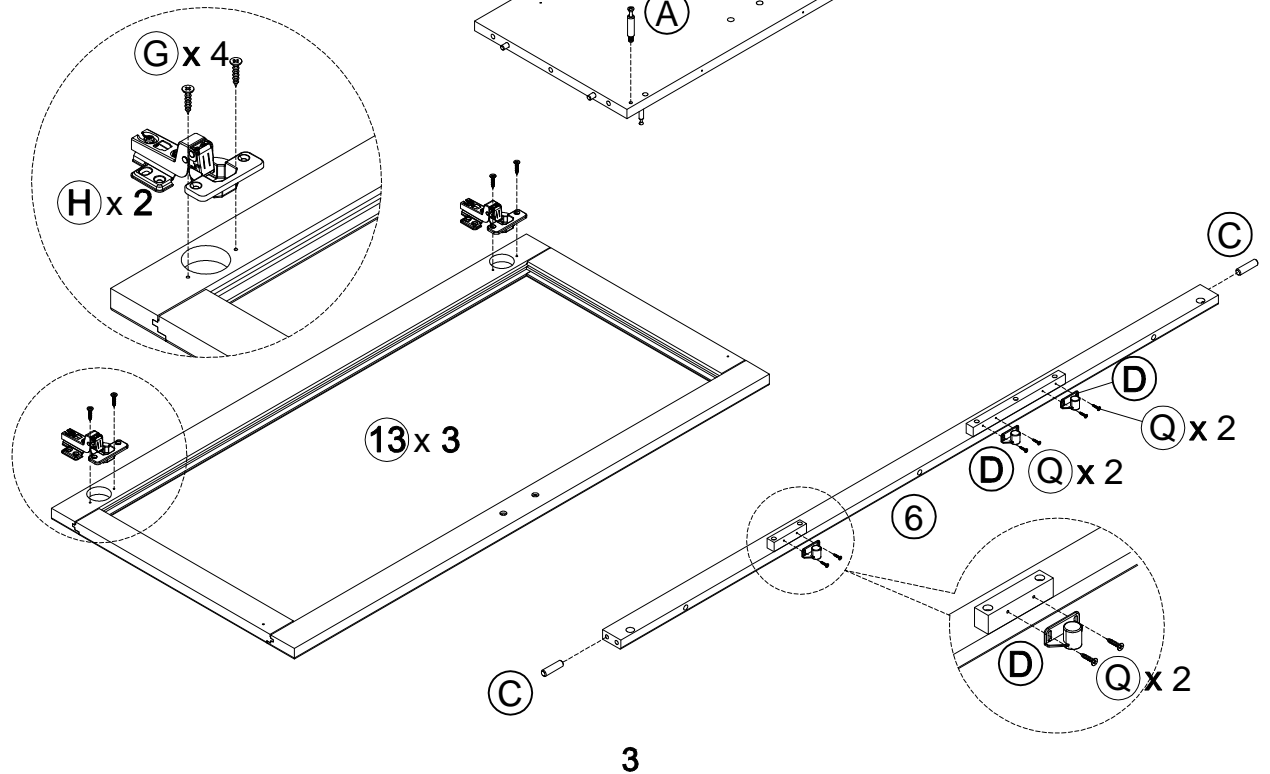
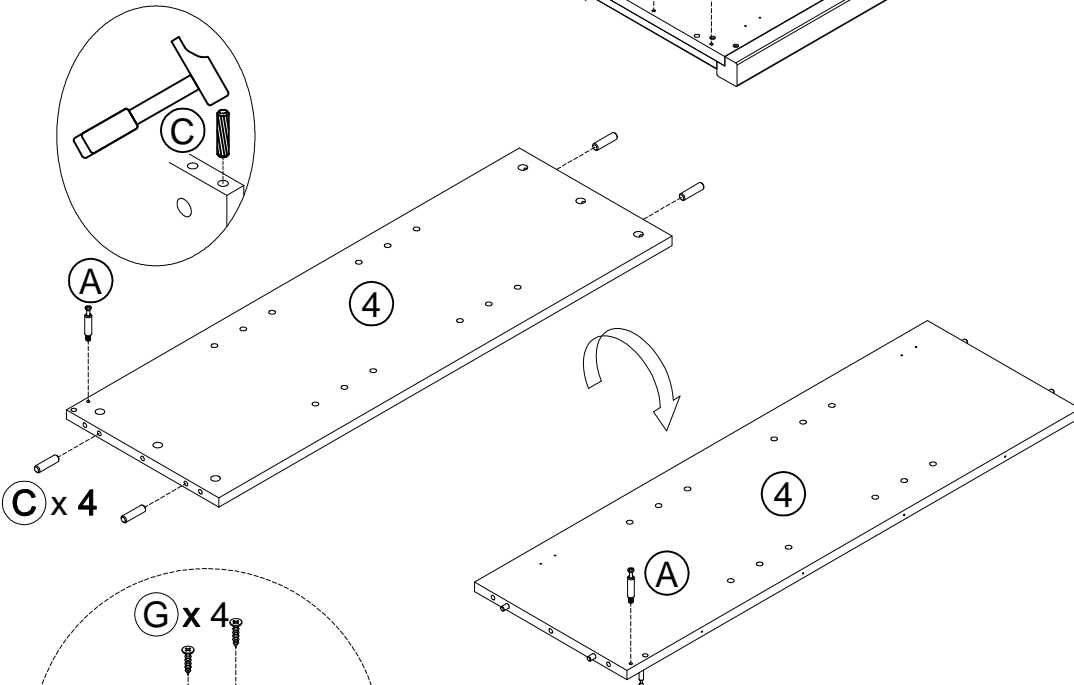
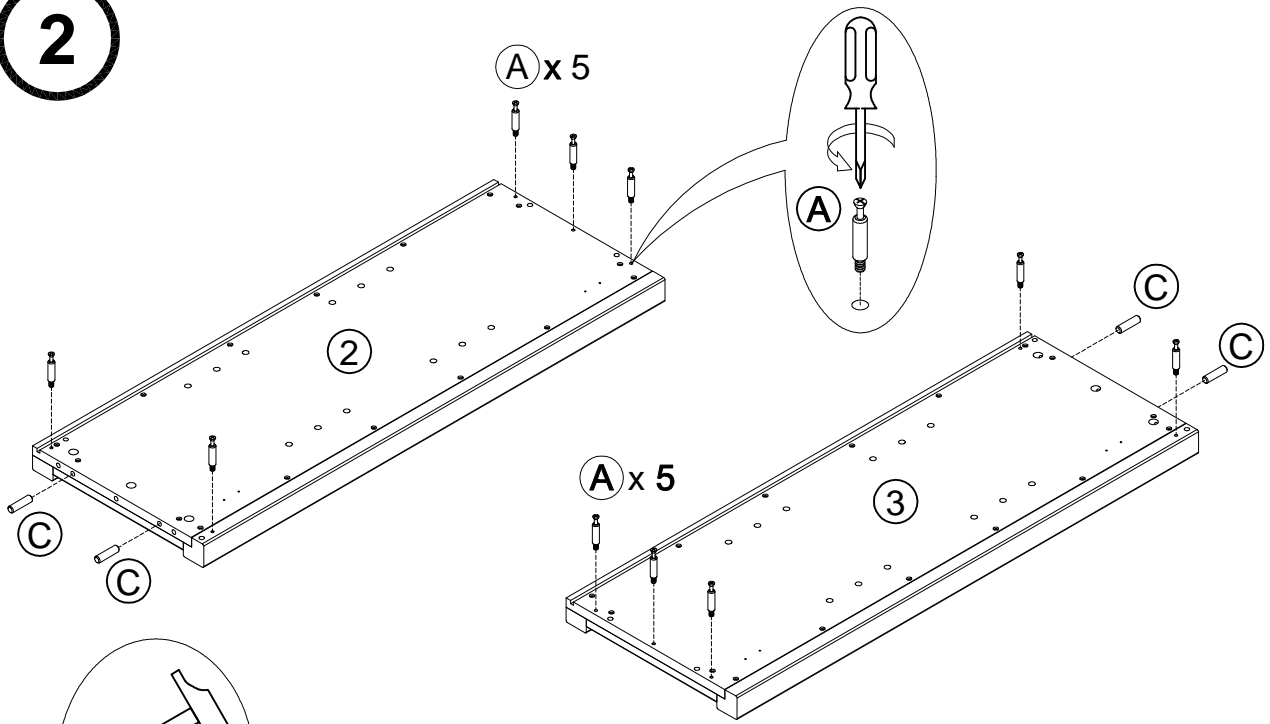

3

3

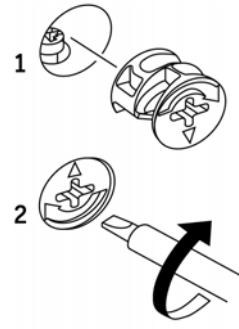
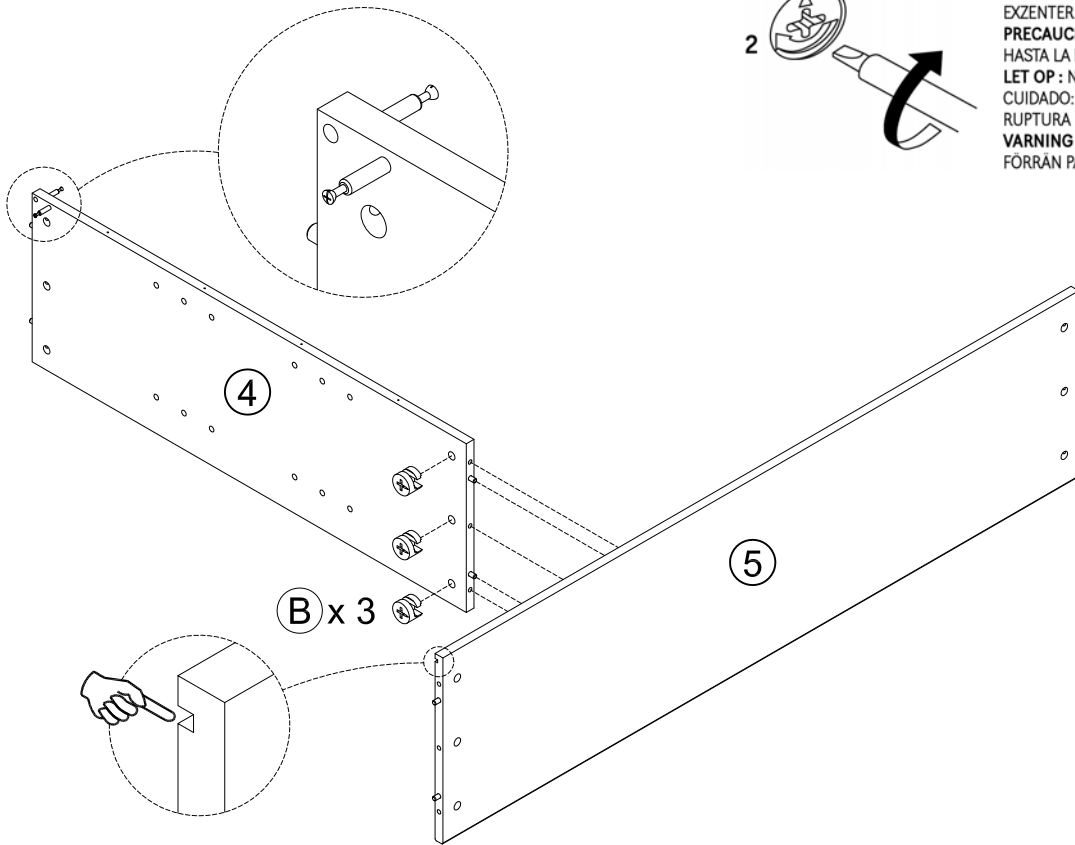

ATTENTION : NE PAS SERRER JUSQU'À RUPTURE DE L'EX-CENTRIQUE
CAUTION : DO NOT TIGHTEN UNTIL BREAK OF THE ASSEMBLY FITTINGS
ACHTUNG : NICHT ZU FEST ANZIEHEN BIS ZUM BRUCH DIE EXZENTER
PRECAUCIÓN : NO APRIETE HASTA LA ROTURA
LET OP : NIET VAST TOT BREAK CUIDADO: NÃO APORTE ATÉ RUPTURA
VARNING : SPÄNN INTE FÖRRAN PAUS SNÄCKORS

4

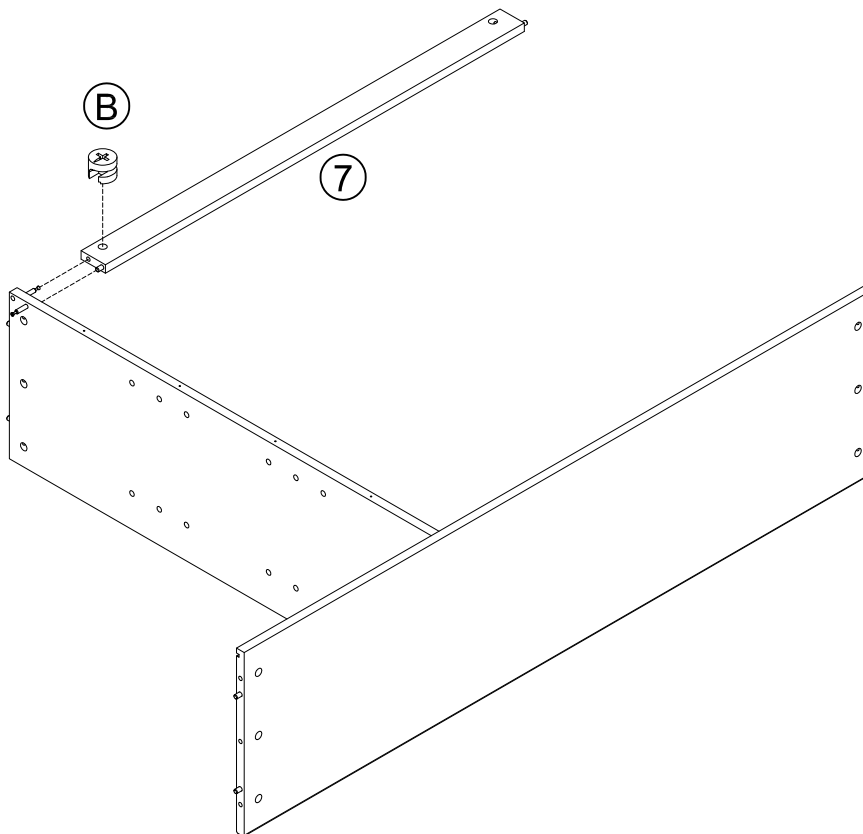

5

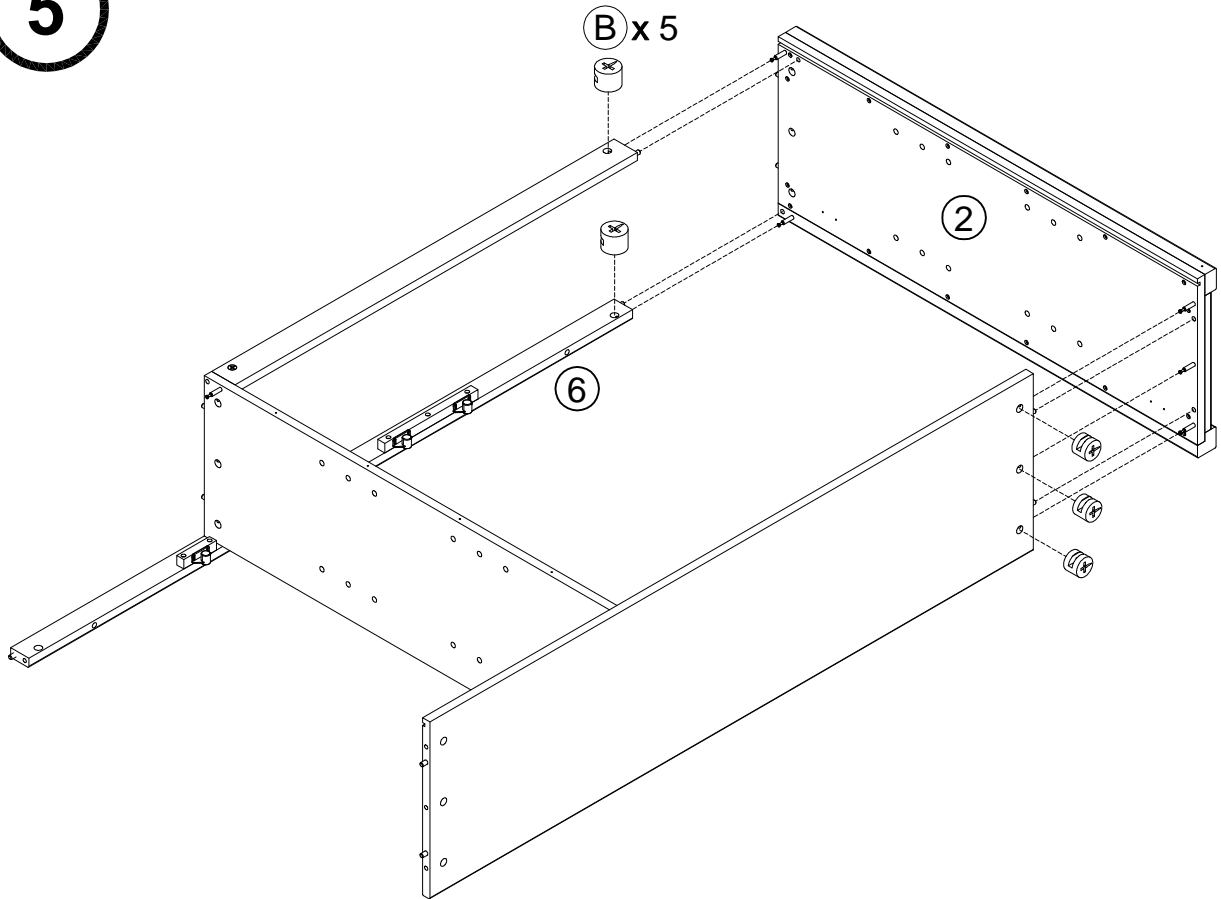

6

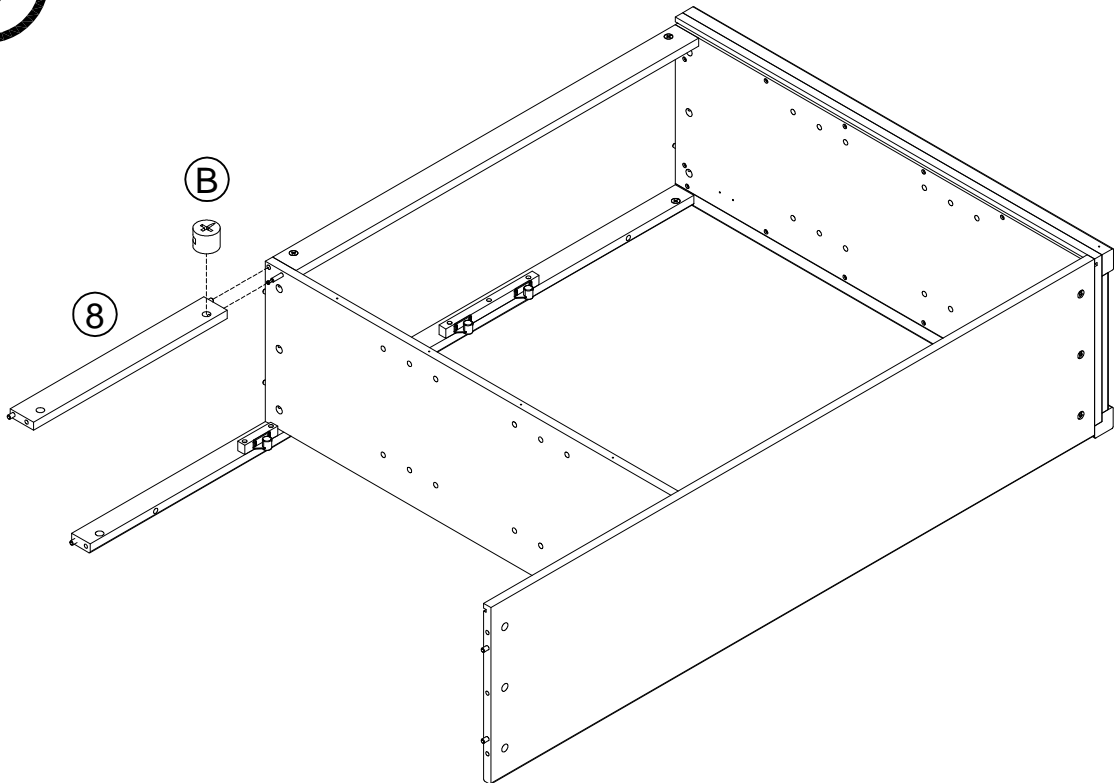

7

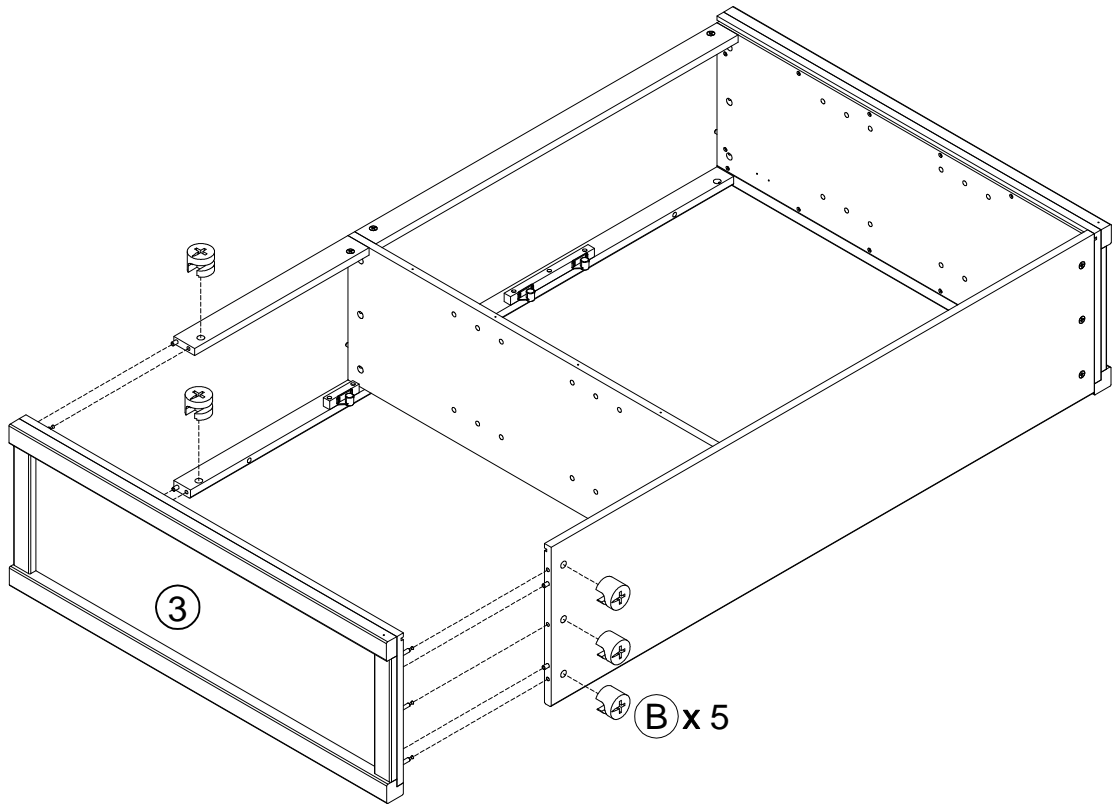

8

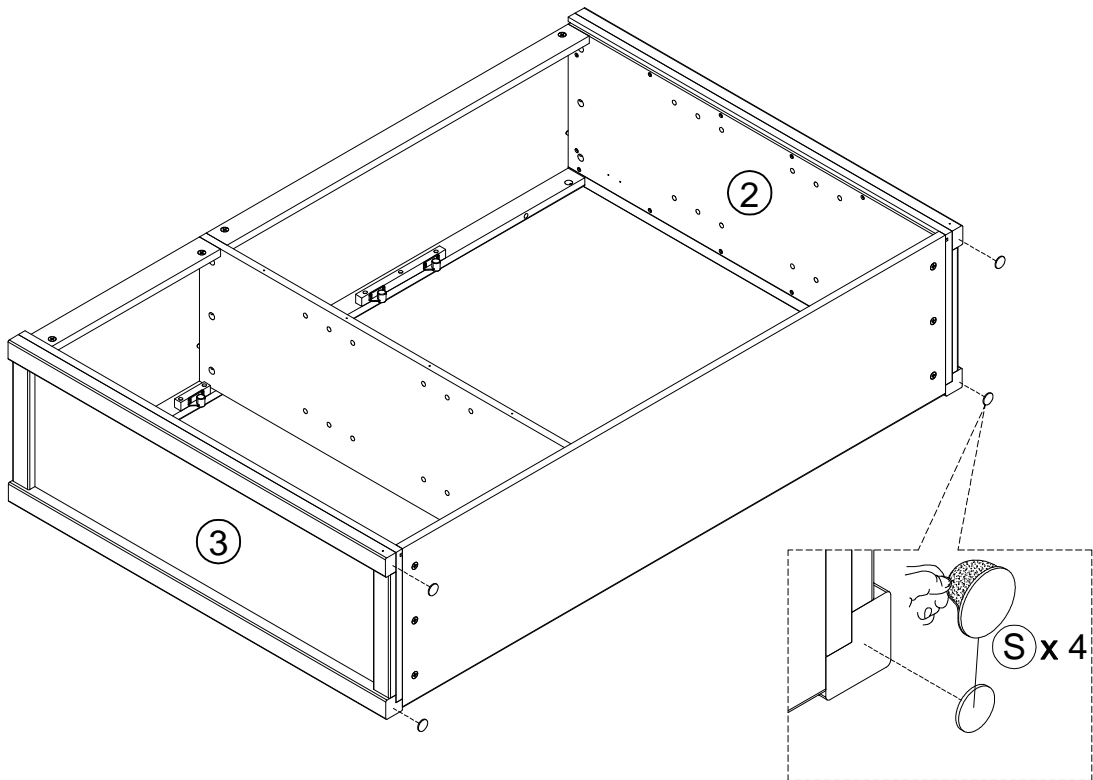

9

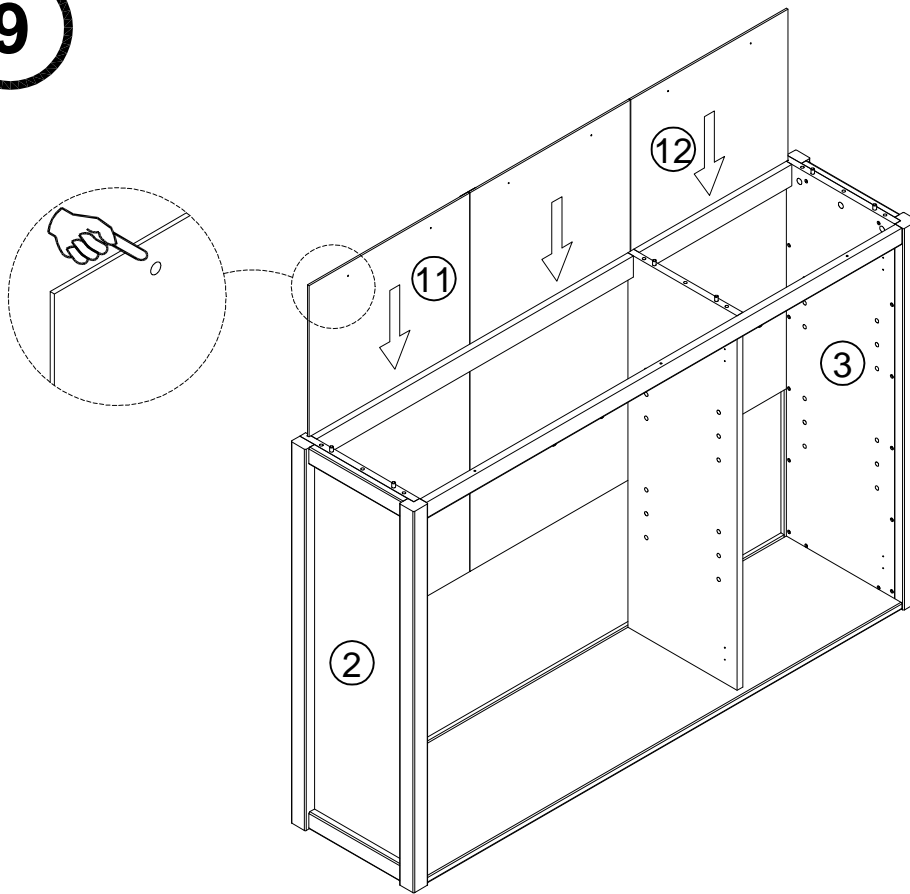

10

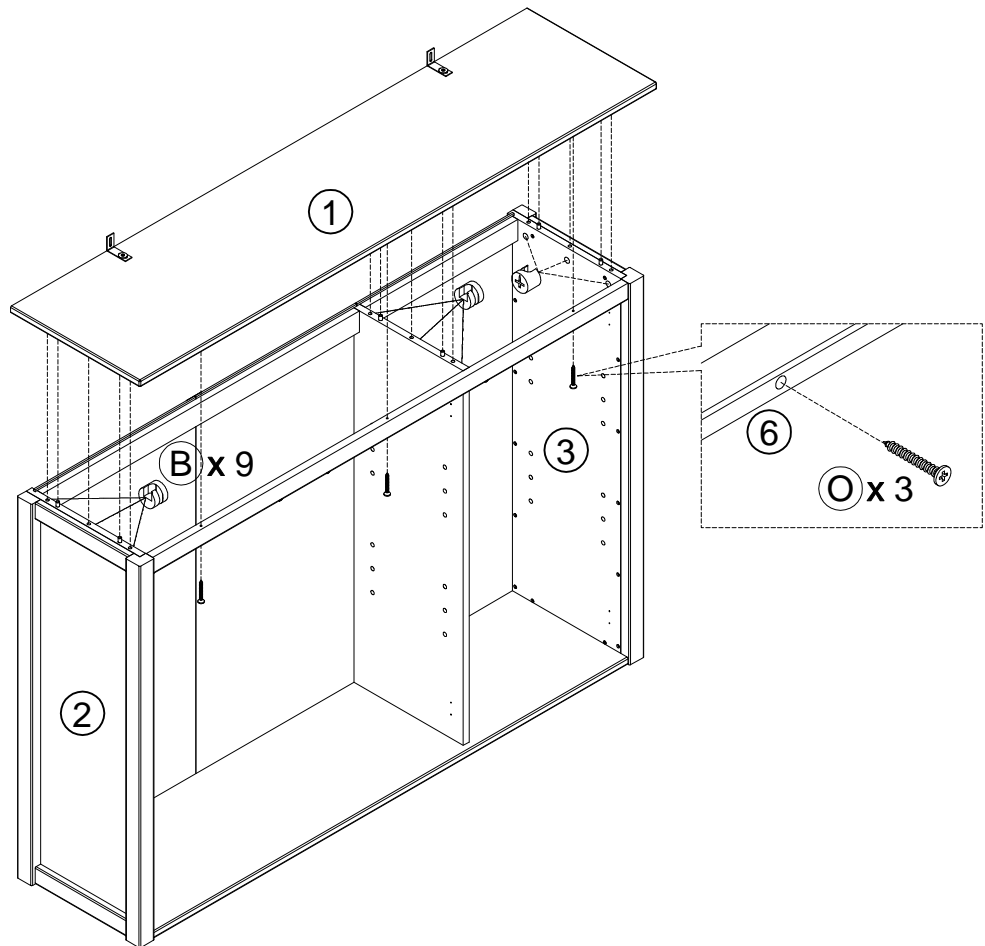

11

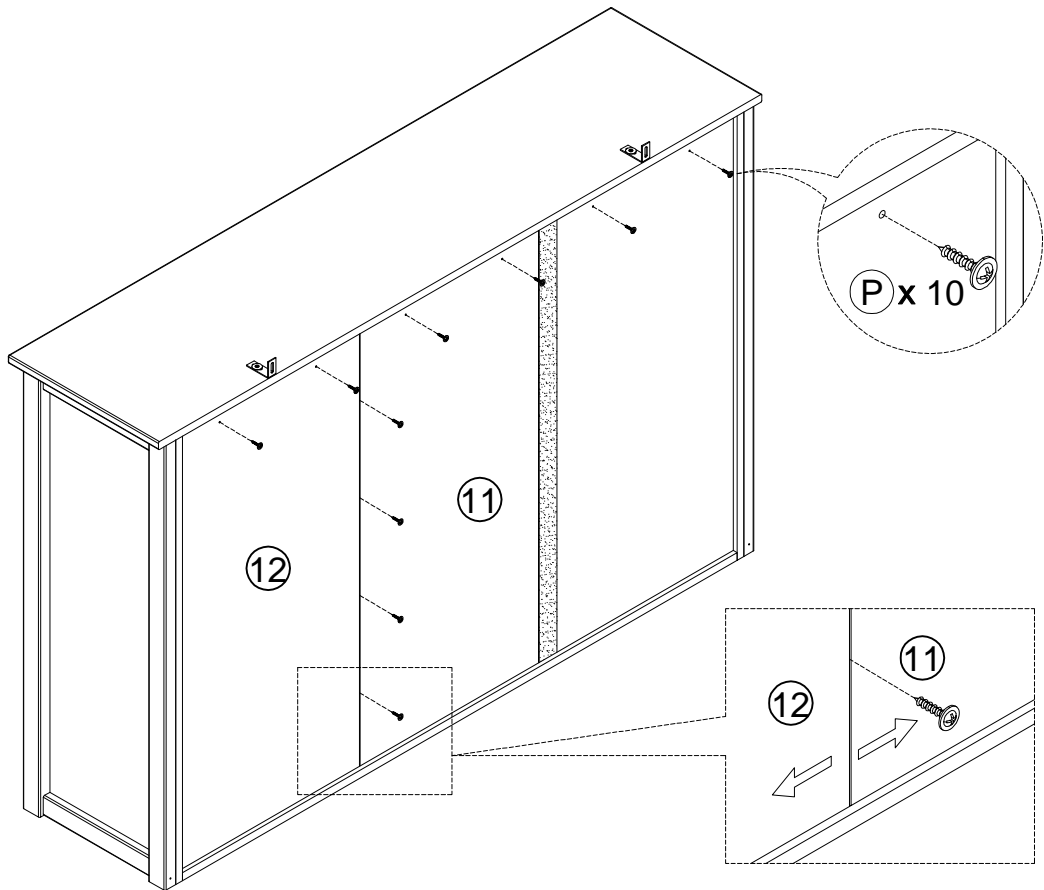

12

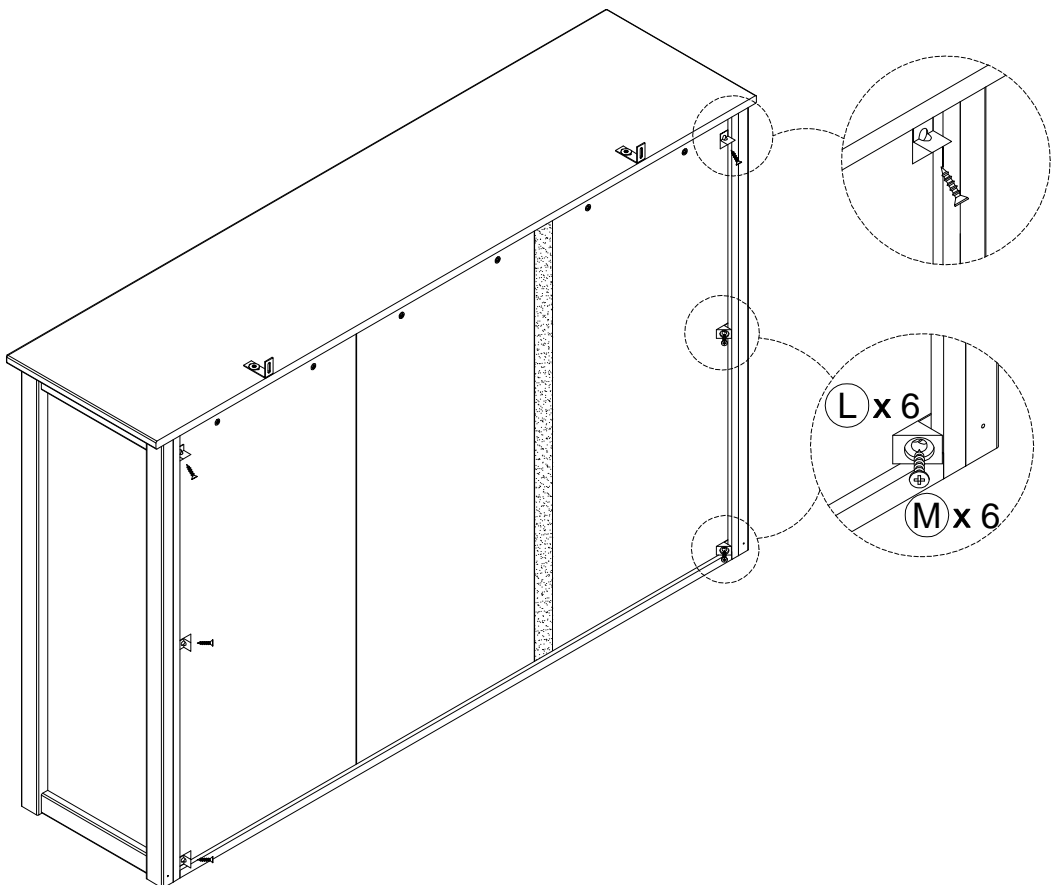

13

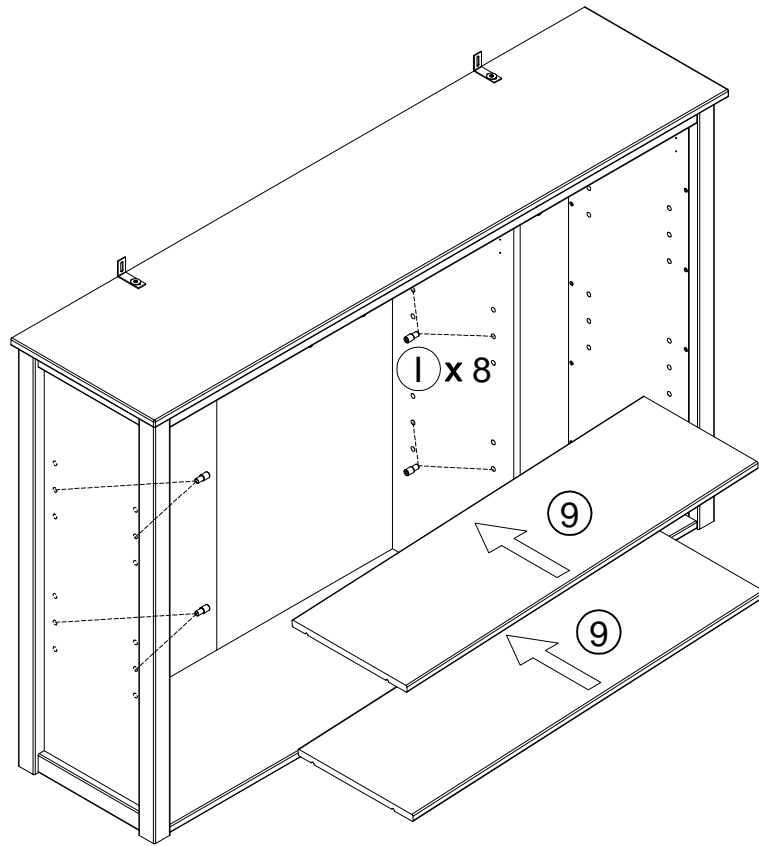

14

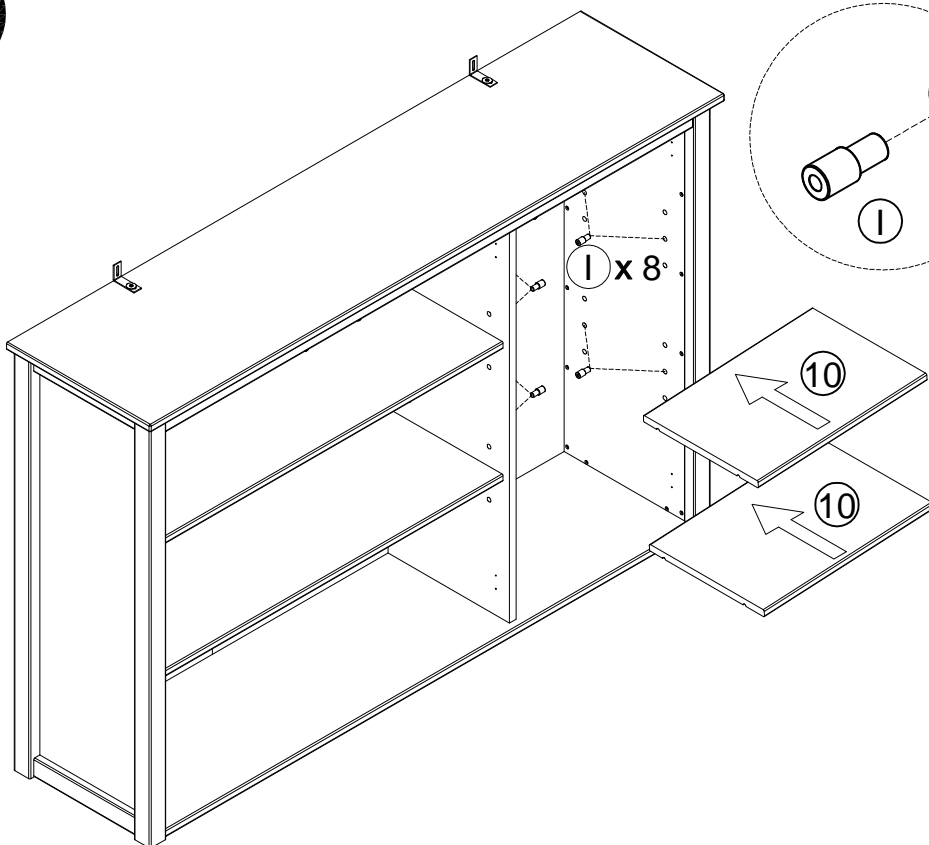

15

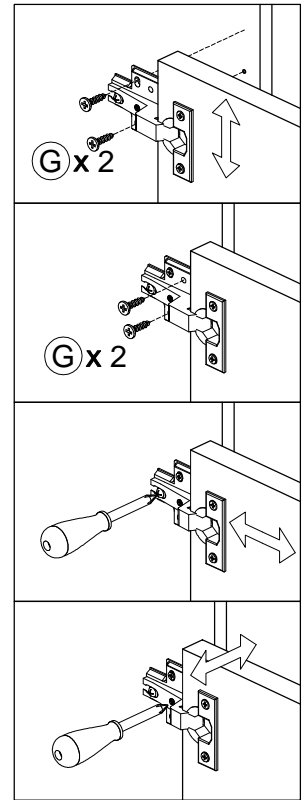
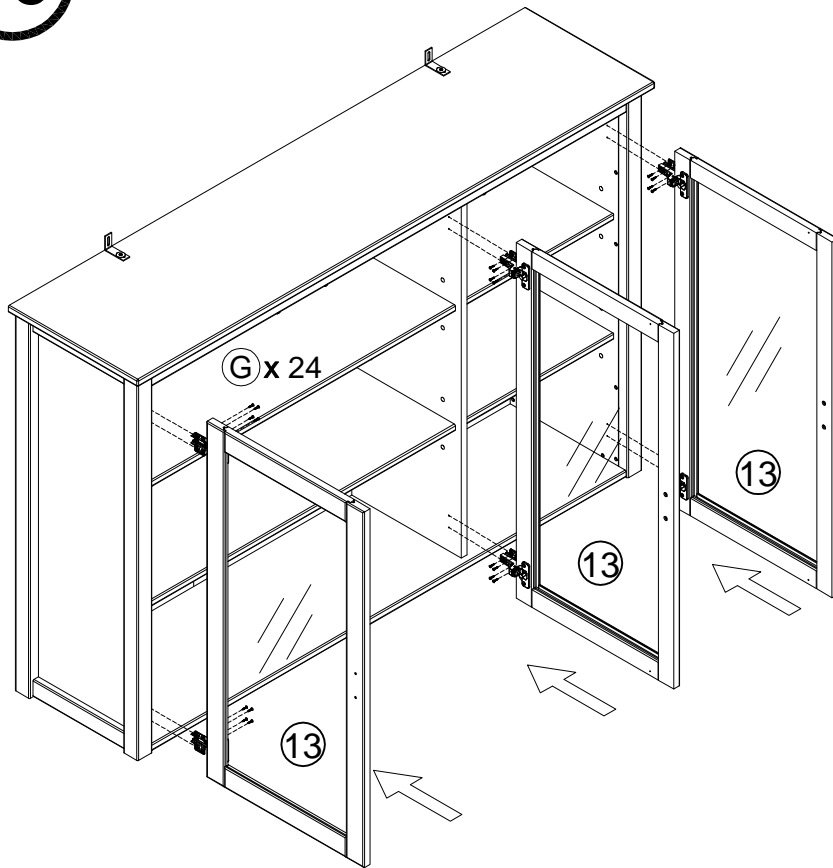

16

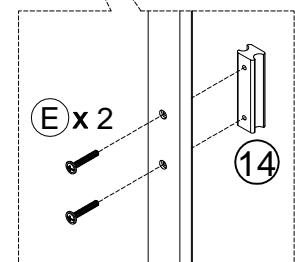
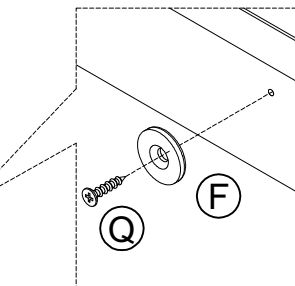
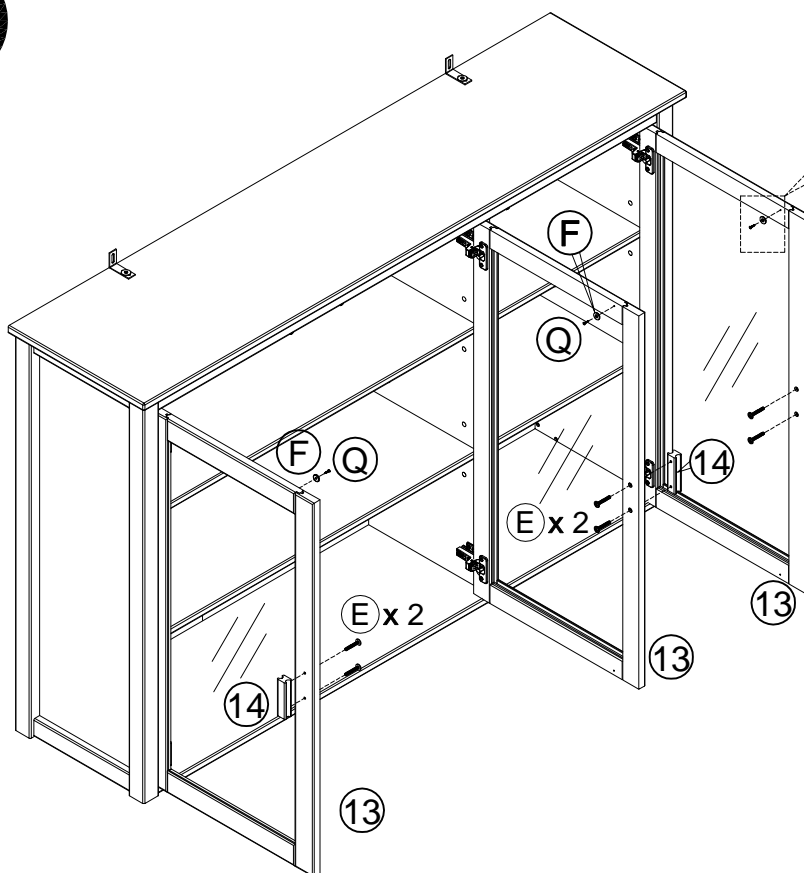

17

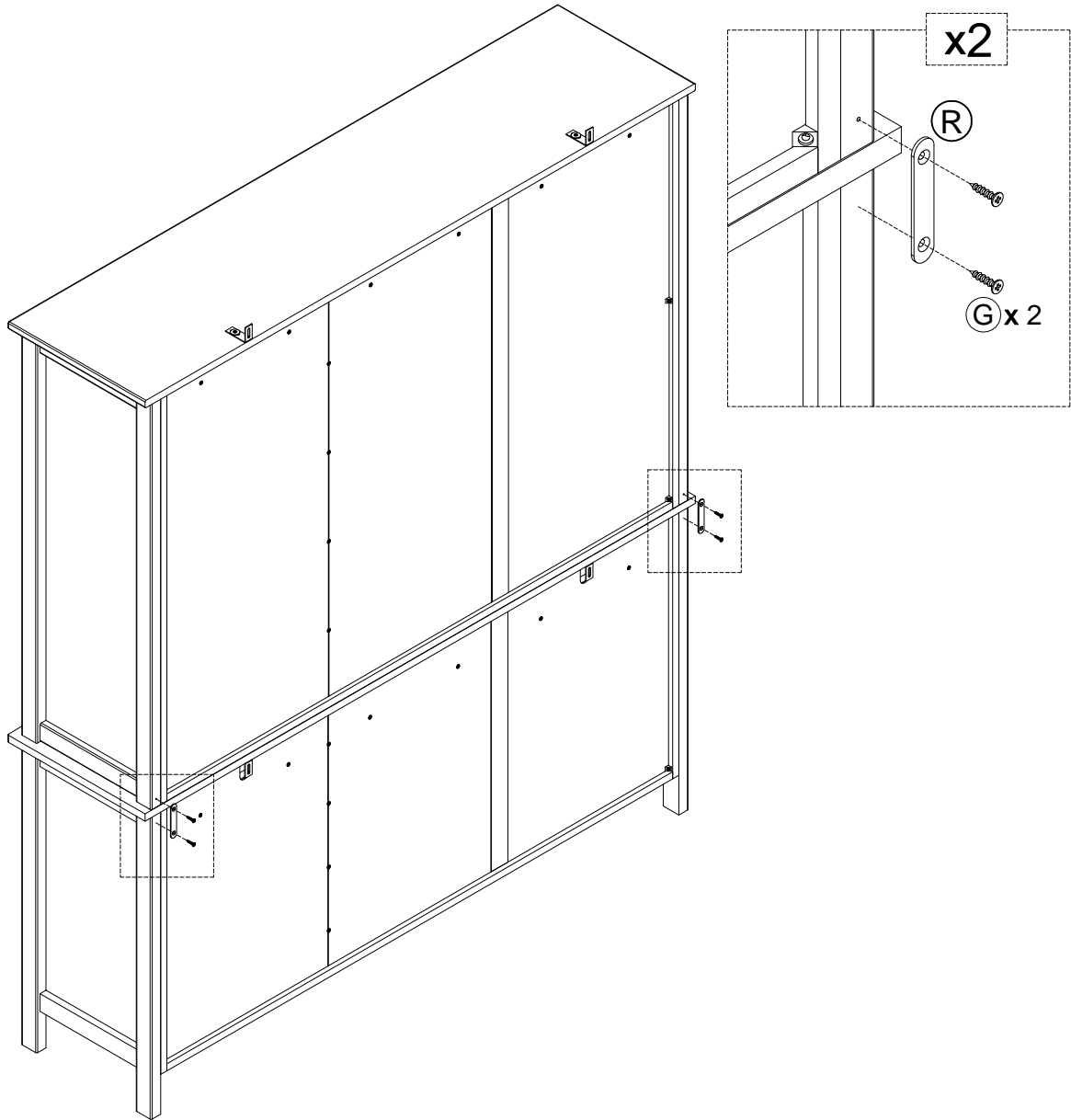

18

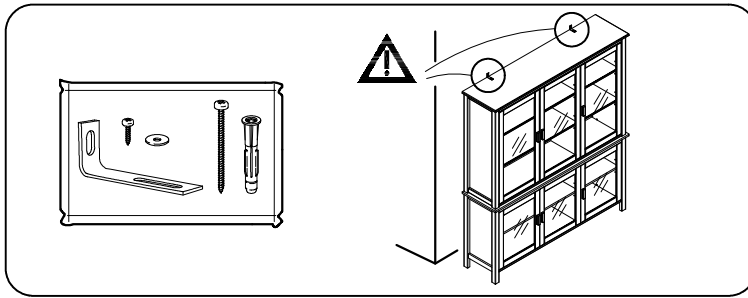

la cheville et la vis pour la fixation murale ne sont pas fournis car ils dépendent de la nature de votre

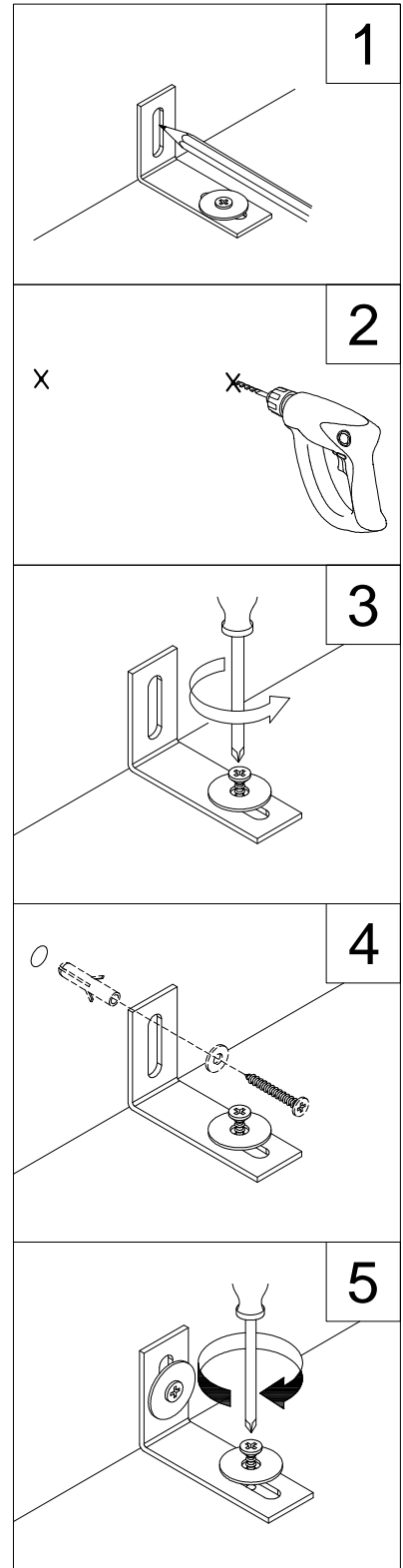
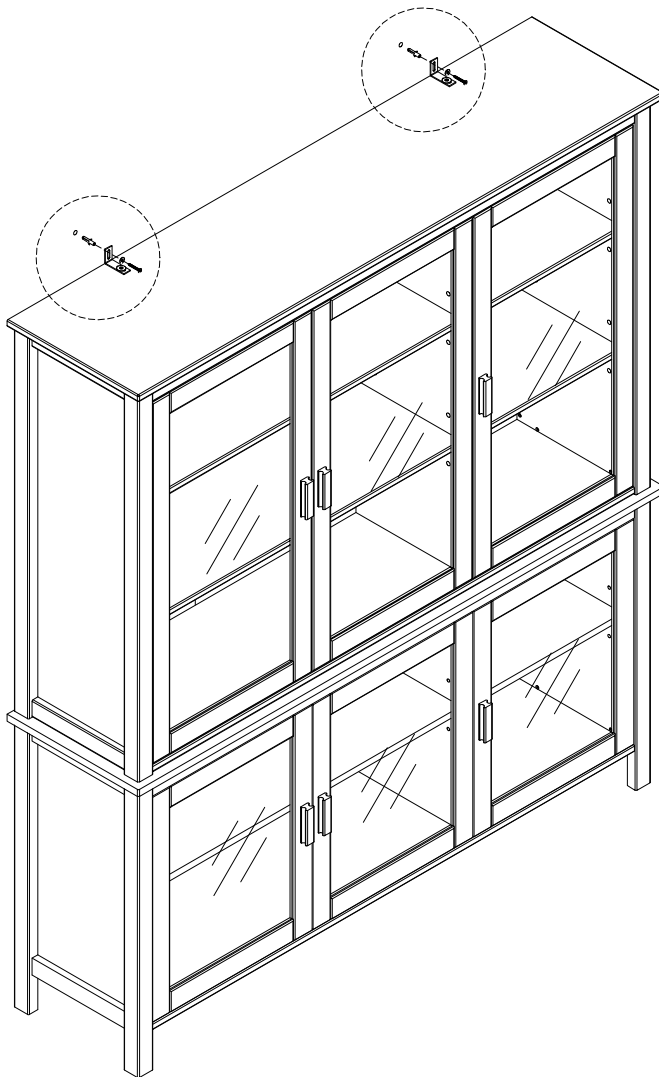

19

