

CHARLES
BENTLEY

EST. 1860



excellent
**EVERY
TIME**

ottimo[🔥]
USER GUIDE

**Ottimo Pro 455
6-Burner Gas BBQ**

BBQGAS05

 **ottimo**



OTTIMO
MILANO
ITALY

excellent
**EVERY
TIME**

share

BBQ
lovers

FLAVOUR

**SEAR
SMOKE
BROIL**

grilled to
PERFECTION

CONTENTS



GETTING
STARTED
PAGES 4 - 6



MAINTENANCE
INSTRUCTIONS
PAGE 7



WARRANTY
PAGE 8

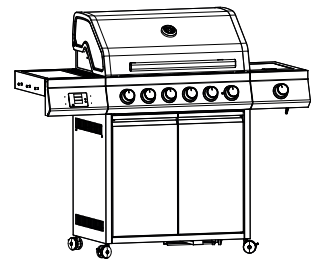

WHAT'S IN
THE BOX
PAGES 9 - 14



ASSEMBLY
GUIDE
PAGES 15 - 29

GENERAL SAFETY



IMPORTANT: Failure to follow these safety instructions may result in serious injury, property damage, or voiding of your warranty. Please read carefully before using your barbecue.

GENERAL USE

- Retain this manual for future reference.
- Use outdoors only in a well-ventilated area.
- Keep the BBQ away from buildings, fences, trees, and overhangs.
- Never use your BBQ in enclosed spaces (e.g. tents, garages, conservatories).
- Keep children and pets away during and after use until fully cooled.
- Never leave the BBQ unattended while in operation.
- Avoid using the BBQ if under the influence of alcohol or medication.

GAS SAFETY

- Use a regulator compliant with UK standards.
- Check hoses and connections for wear or damage before each use.
- Perform a leak test using soapy water (never a flame).
- **DO NOT** attempt to disconnect gas fittings while the appliance is in operation.
- Turn off the gas supply first, then BBQ controls after cooking.
- Store gas cylinders upright in a cool, ventilated area.
- Never modify the regulator, burners, or pressure system.

FIRE SAFETY

- Keep flammable materials (e.g. petrol, aerosols) at least 1 metre away.
- Use heat-resistant gloves when handling hot parts.
- Ensure the BBQ is placed on a stable, level surface.
- Have a fire extinguisher or bucket of sand nearby just in case.
- The risk of fire is increased due to “flare ups”, especially when grilling high-fat meats if the lid is kept closed. Keep the lid open or slightly ajar when cooking fatty foods.
- **DO NOT** move the BBQ while in use or while still hot.
- Further safety information is available at: <https://www.fireservice.co.uk/safety/barbecue/>

CONNECTING UP YOUR GAS CYLINDER

CONNECTING YOUR BBQ TO YOUR GAS CYLINDER

1. The cylinder valve should be in the **OFF** position.
2. Ensure the BBQ is switched **OFF**.
3. Inspect the valve connections, port and regulator.
4. Remove debris and inspect the hose for damage.
5. When connecting the regulator to the valve, use your hand to tighten the nut clockwise until it stops. **Note:** using a spanner or wrench could damage the quick coupling nut.
6. Open the cylinder valve fully by turning the valve counterclockwise.
7. Before lighting your BBQ, use a soap and water solution to check all connections for leaks.
8. If a leak is found, turn the cylinder valve **OFF**, and do not use your BBQ until it is repaired or replaced.

DISCONNECTING YOUR BBQ TO YOUR GAS CYLINDER

1. Turn the gas **OFF** at the regulator/cylinder.
2. Check that all flames from the gas burner in the BBQ are extinguished.
3. Turn the knobs on your BBQ **OFF** and make sure your BBQ is cool.
4. Make sure that the gas supply from the gas cylinder to the BBQ is closed.
5. When the BBQ is not in use, always remove the low pressure regulator from the gas cylinder.

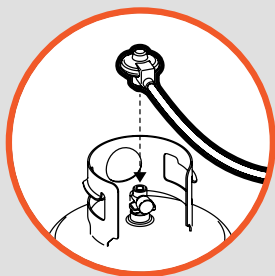

ATTACHING YOUR PATIO GAS REGULATOR

(This is a push-on gas fitting)

1. Ensure that the black switch is in the horizontal position.
2. Depress the button located below the black switch and press the regulator on to the cylinder valve until it locks into place.



Safety Instructions Always keep the gas cylinder in an upright position. The size for 20lbs LP gas cylinder is 12.2 inches in diameter and 17.9 inches tall. When your BBQ is not in use, the gas must be turned off at the supply cylinder. The cylinder must include a collar to protect the cylinder valve.

LIGHTING GUIDE

- Open the lid.
- Connect the regulator to the gas bottle.
- Turn on the gas supply at the cylinder.
- Check for gas leaks using soapy water around the connection between the bottle and regulator.
- Push and turn the burner control knob to the “ignite” or “start” position.
- Press the ignition button (you may hear a clicking sound).
- If the burner doesn't light within a few seconds, turn off the gas and wait 5 minutes before trying again.
- Once lit, adjust the flame and light other burners as needed, following the instructions above.
- A low cooking flame is recommended to ensure even cooking and prevent burning or undercooking food.
- Adjust the heat by turning the knob between the “High” and “Low” positions.
- To turn the barbecue off, turn the cylinder valve or regulator switch to the **OFF** position.

COOKING GUIDE

COOKING FOOD SAFELY ON A GAS BBQ

- Preheat the BBQ and ensure it reaches a high enough temperature before cooking.
- Turn meat regularly to cook it evenly and avoid burning the outside while leaving the inside raw.
- Use a food thermometer to check internal temperatures:
 - Poultry (chicken, turkey): 75°C
 - Pork, sausages, burgers: 75°C
 - Beef steaks: Can be served rare, but the outside must be seared.
- Check meat is cooked:
 - Juices run clear (not pink or red).
 - No pink meat inside.
 - Piping hot throughout.

SERVING & LEFTOVERS

- Serve food immediately after cooking or keep it hot (above 63°C).
- **DO NOT** leave food out for more than 2 hours (1 hour if it's hot outside).
- Cover food to protect from insects and contamination.
- Cool leftovers quickly and refrigerate within 90 minutes.
- Reheat leftovers only once, ensuring they reach 75°C throughout.

AVOIDING CROSS-CONTAMINATION

- **NEVER** reuse marinades that have touched raw meat unless boiled first.
- Use clean plates for cooked food – don't reuse ones that held raw meat.
- Keep pets and children away from food prep and cooking areas.

MAINTENANCE INSTRUCTIONS

CLEANING

Regular cleaning helps maintain the performance, appearance, and safety of your BBQ.

After Each Use

- Allow the BBQ to cool completely.
- Remove and clean grates and drip trays with warm soapy water.
- Wipe down exterior surfaces with a damp cloth and soapy water.
- Clean the lid and interior to prevent grease build up.
- **DO NOT** use harsh chemicals, oven cleaners, or bleach on any part of the BBQ as this will damage the paint/finish.

Deep Cleaning (Monthly or Seasonally)

- Remove burners and clean with a non-abrasive brush.
- Use a BBQ-safe degreaser for stubborn residue.
- Clean the inside of the lid to prevent flaking.
- Clean the control panel carefully to avoid moisture getting into the ignition system.
- Rinse thoroughly and dry all parts before reassembly.

Burn off

- The burn-off technique (running the BBQ at high heat to clean it) is not recommended and if used should only be used occasionally for a short periods. Prolonged high heat may cause the BBQ to overheat and fats/oils with catch fire and damage the BBQ.

STORAGE

Short-Term

- Cover the BBQ with a weatherproof cover when not in use.
- Disconnect the gas cylinder if not you BBQ is not in use for several days.

Long-Term (Winter or Off-Season)

- Clean thoroughly before storing.
- Disconnect and store the gas cylinder outdoors, upright, and away from direct sunlight.
- Paint any exposed metal on the outside with high temperature paint before storing.
- Lightly oil any exposed parts inside to prevent corrosion.
- Store the BBQ ideally in a dry, sheltered location (e.g. a shed or garage).
- Cover with a ventilated BBQ cover to prevent moisture buildup.

WARRANTY

For full details and to register for your extended warranty please visit charlesbentley.com/warranty

Please retain your receipt/proof of purchase for all warranty claims.

Product Code	12362
Gas Category	Cat: I3+(28 -30/37)
Gas	Butane, propane
Operating Pressure	Butane: 28-30mbar /Propane: 37mbar
Total Power	23kW(1764g/h)
Nozzle Size	Main Burner 0.84mm, Side Burner 1.05mm
Pin Code	 2531-26 PIN: 2531DQ-0071
Manufactured in China by May Home Product Limited for Charles Bentley & Son Ltd.	



WHAT'S IN THE BOX





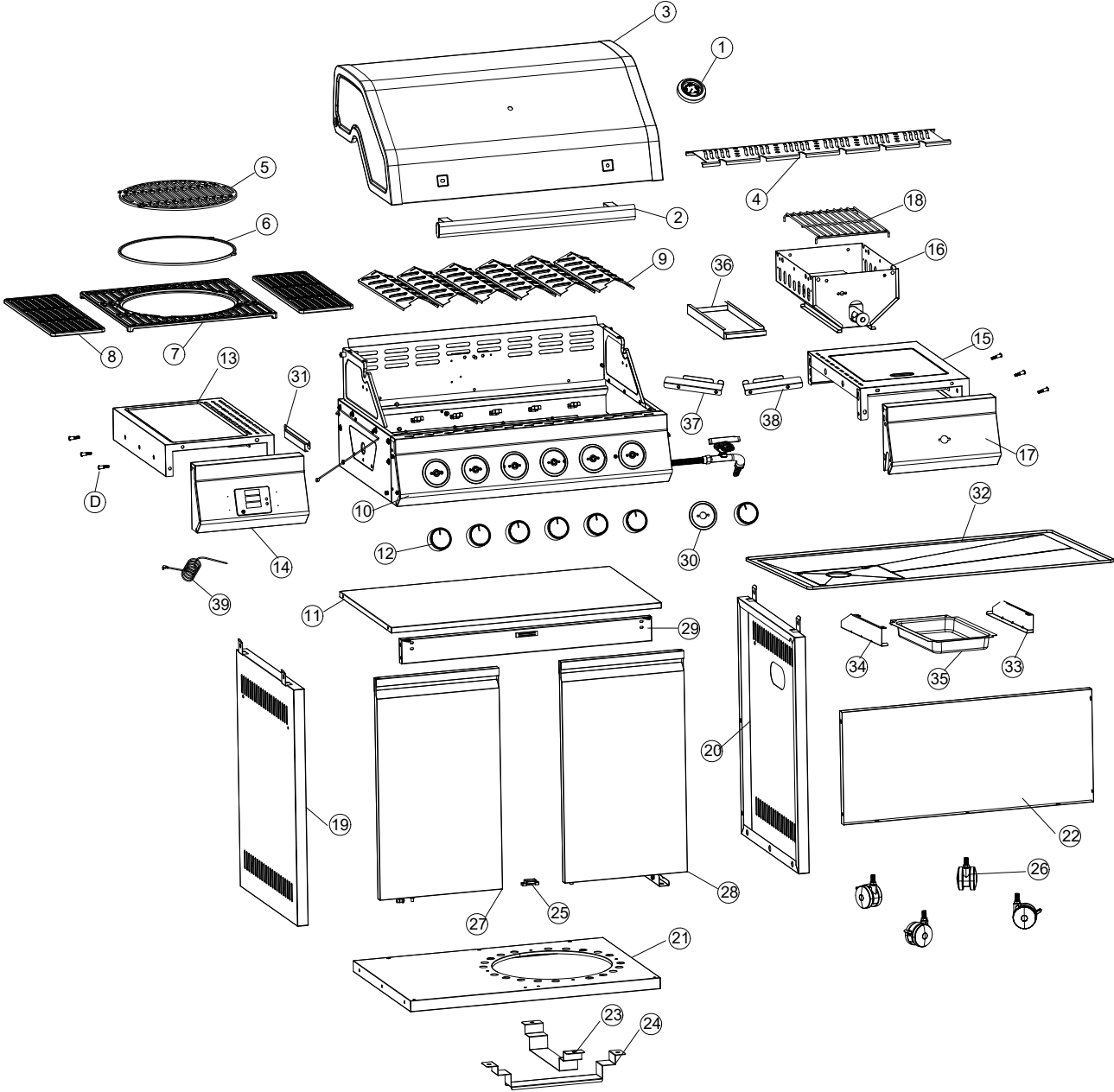

PARTS DIAGRAM



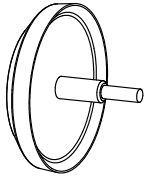

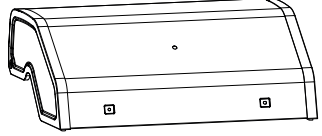
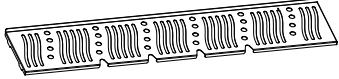
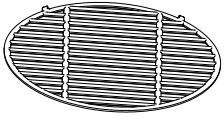
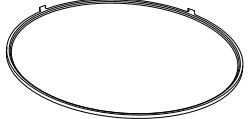
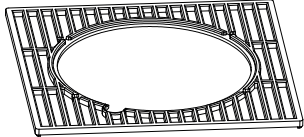
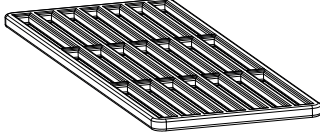
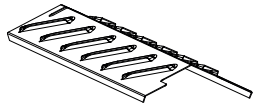
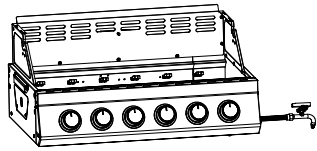

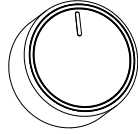
PARTS LIST

WHAT'S IN THE BOX

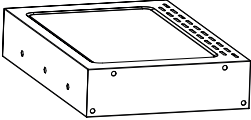
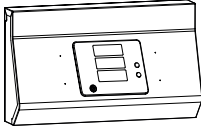
1 x1  Thermometer	2 x1  Lid Handle	3 x1  Lid
4 x1  Warming Rack	5 x1  Round Cooking Grill	6 x1  Round Cooking Plate
7 x1  Cooking Grill	8 x2  Rectangular Cooking Grill	9 x6  Flame Tamer
10 x1  Grill Body	11 x1  Gas Cylinder Insulation Board	12 x7  Knob

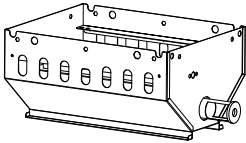
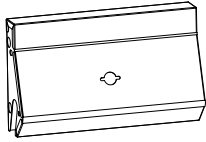
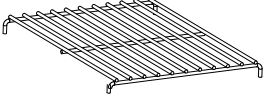
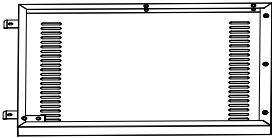
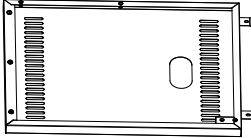
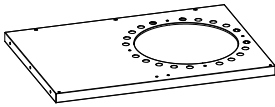
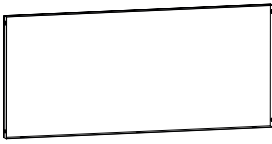
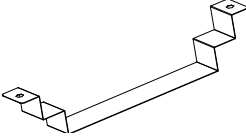
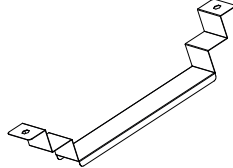
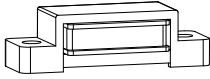
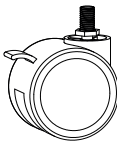
PARTS LIST

<p>13 x1</p>  <p>Sidetable (Left)</p>	<p>14 x1</p>  <p>Side Table Control Panel (Left)</p>	<p>15 x1</p>  <p>Side Table With Burner (Right)</p>
<p>16 x1</p>  <p>Side Burner</p>	<p>17 x1</p>  <p>Side Burner Front Panel (Right)</p>	<p>18 x1</p>  <p>Side Burner Cooking Support</p>
<p>19 x1</p>  <p>Side Wall (Left)</p>	<p>20 x1</p>  <p>Side Wall (Right)</p>	<p>21 x1</p>  <p>Bottom Shelf</p>
<p>22 x1</p>  <p>Back Wall</p>	<p>23 x1</p>  <p>Gas Cylinder Support A</p>	<p>24 x1</p>  <p>Gas Cylinder Support B</p>
<p>25 x1</p>  <p>Door Magnet</p>	<p>26 x4</p>  <p>Lockable Wheel</p>	<p>27 x1</p>  <p>Door (Left)</p>

PARTS LIST

WHAT'S IN THE BOX

28

x1



Door (Right)

29

x1



Front Support Bar

30

x1

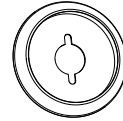

Knob Base

31

x1



Side Table Connector

32

x1

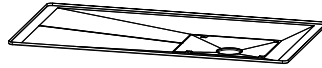

Grease Tray

33

x1

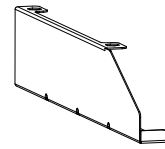

**Grease Tray Support
(Left)**

34

x1

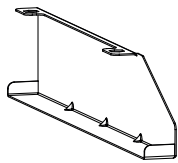

**Grease Tray Support
(Right)**

35

x1

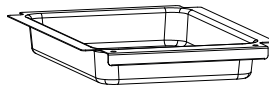

Grease Cup

36

x1



Side Burner Grease Cup

37

x1

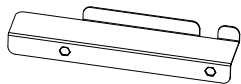

**Warming Rack Support
(Left)**

38

x1



**Warming Rack Support
(Right)**

39

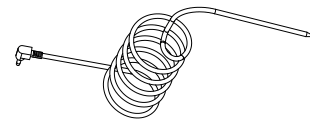

x2



**Food Temperature
Probe**



FIXINGS LIST

A **x20**



M6 x 14mm Bolt

B **x26**





M5 x 12mm Bolt

C **x20**





M4 x 12mm

D **x6**





M6 x 18mm Bolt

E **x4**



M6 x 22mm

F **x2**



M6 x 18mm

TOOLS INCLUDED

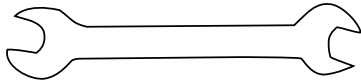

Additional tools may be required.

ASSEMBLY GUIDE



STEP 1

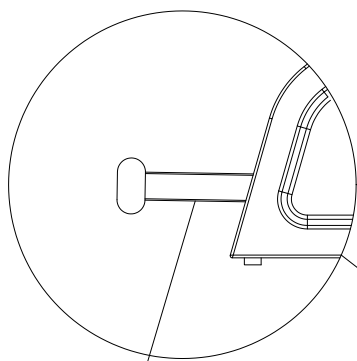

Pay attention to the installation of the handle at an angle.

The screw for fixing the thermometer is pre-installed on the thermometer.

When fitting DO NOT over-tighten the thermometer wing nut.

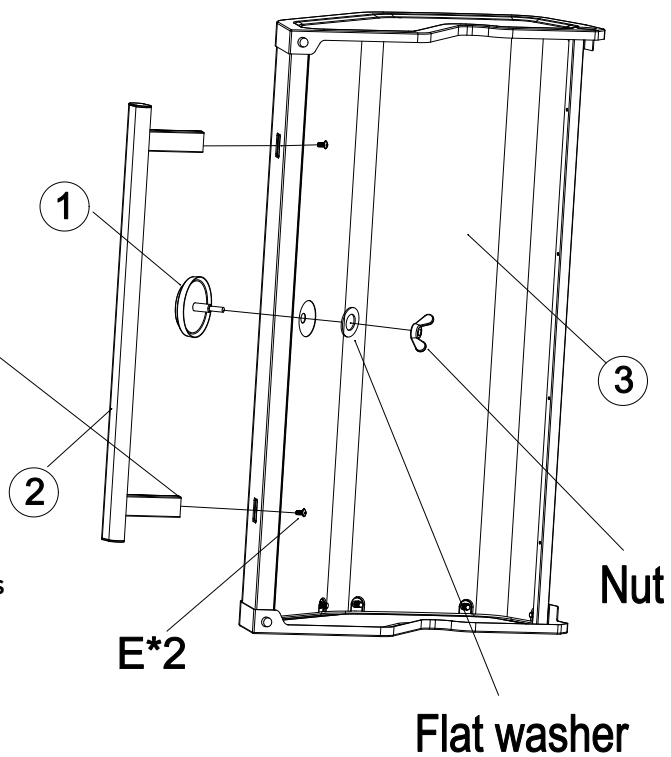

STEP 2

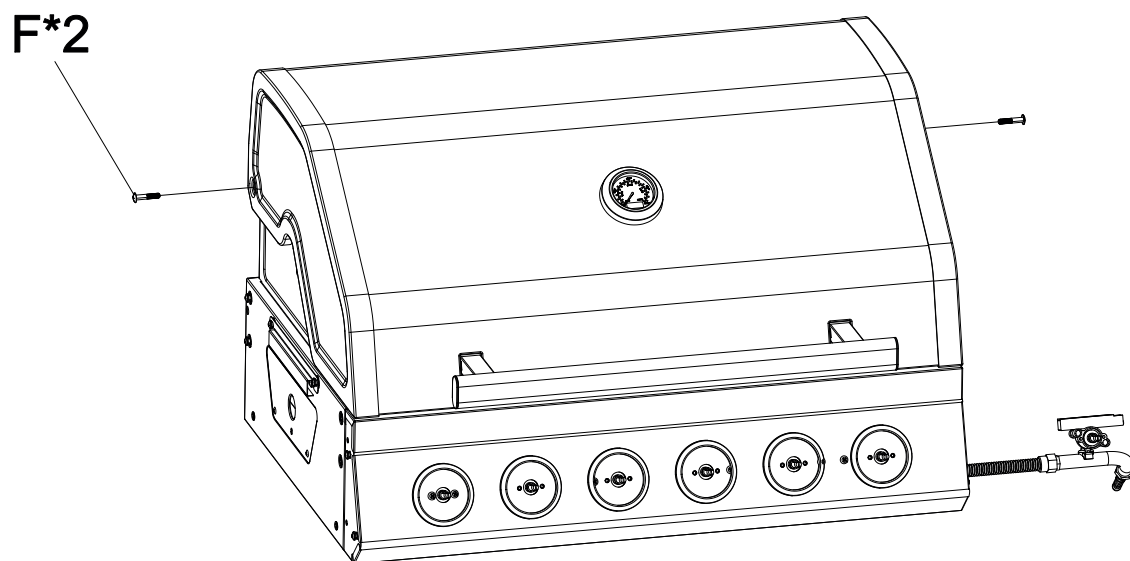

STEP 3

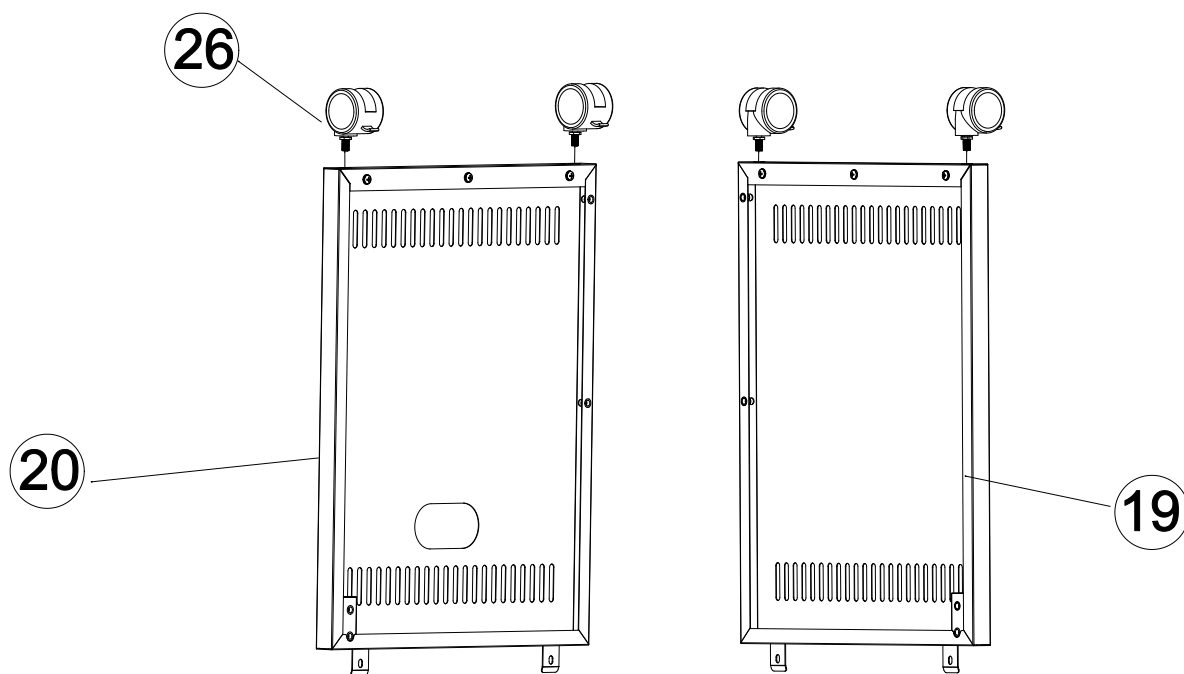

Tighten with a spanner

STEP 4

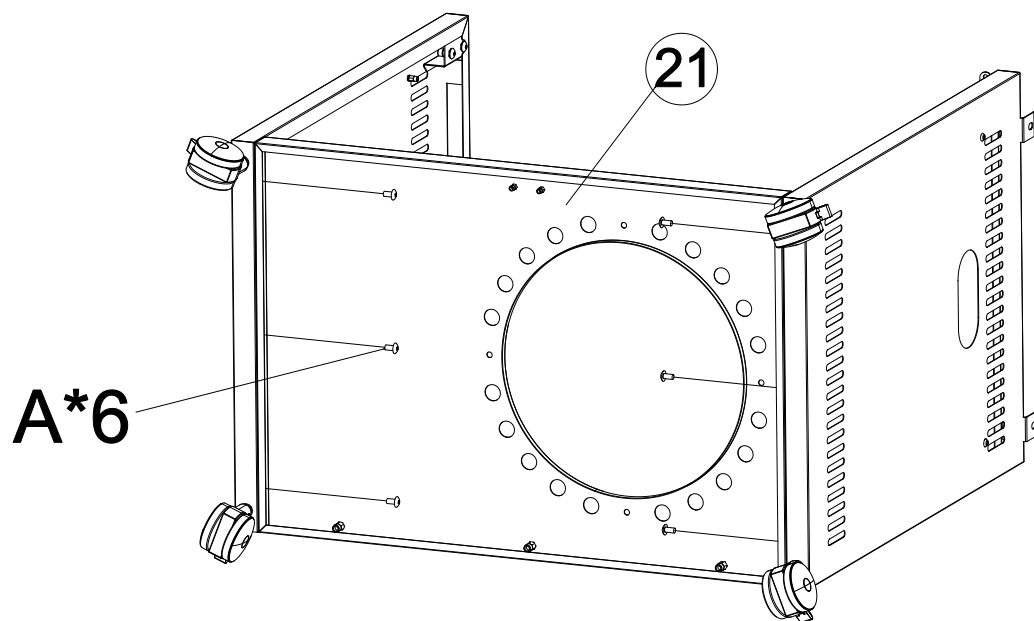

STEP 5

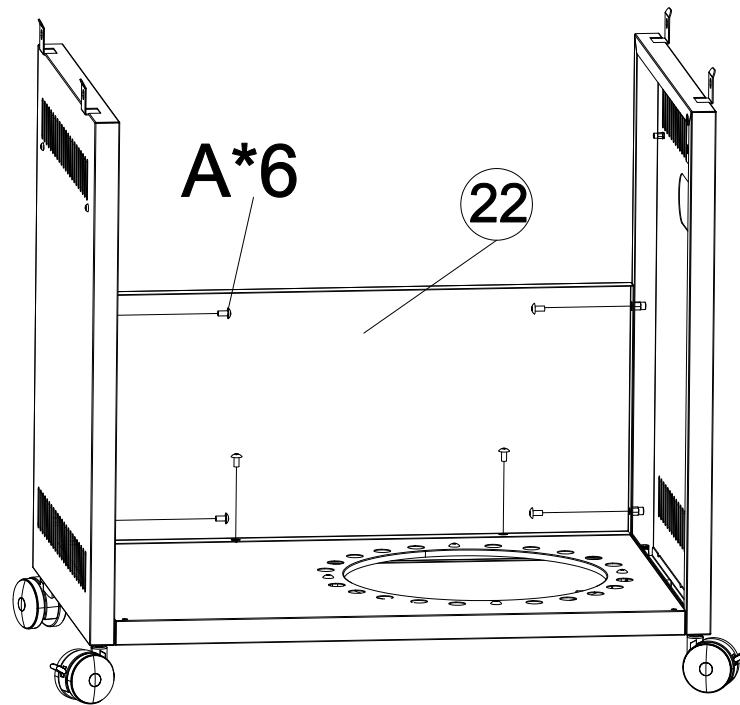

A x6 

STEP 6

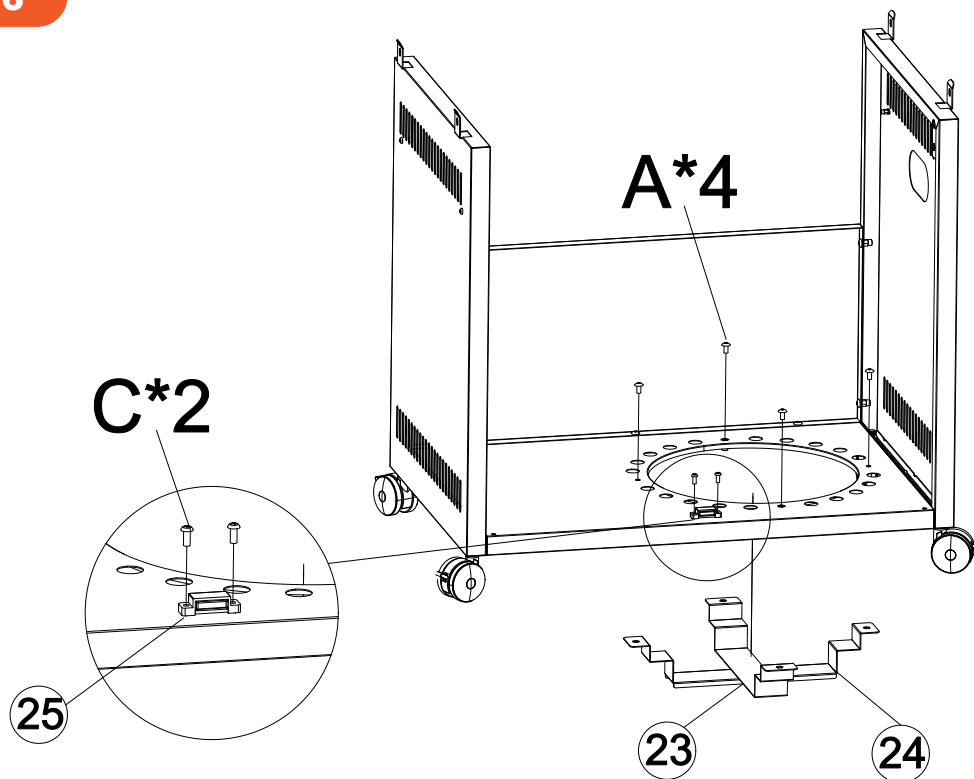

A x4  | **C** x2 

STEP 7

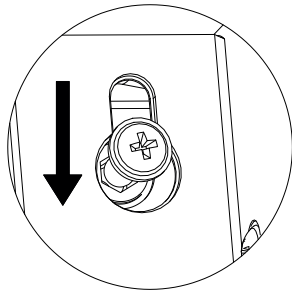

Turn the screws in halfway, hang the parts and then tighten fully to secure.

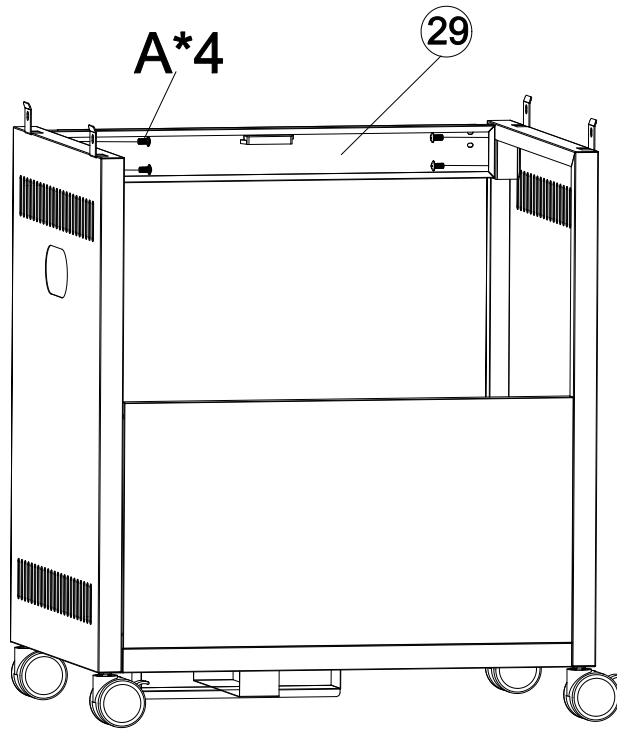

STEP 8

The screw hole position can be moved left and right to adjust the gap in the middle of the door, keeping it uniform

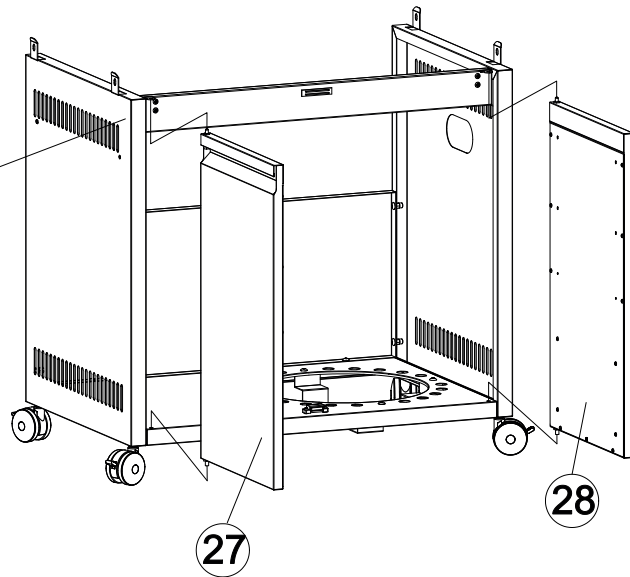
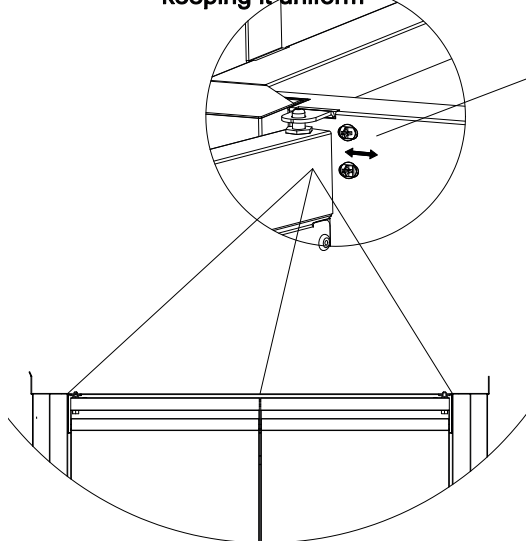

STEP 9

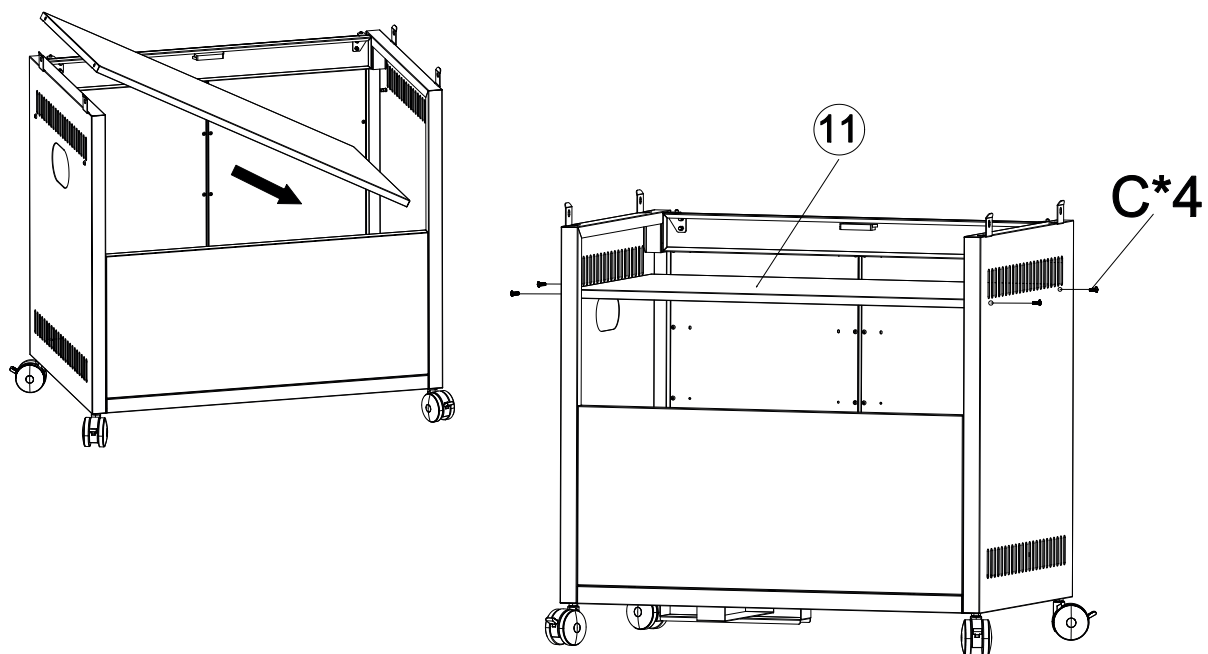

STEP 10

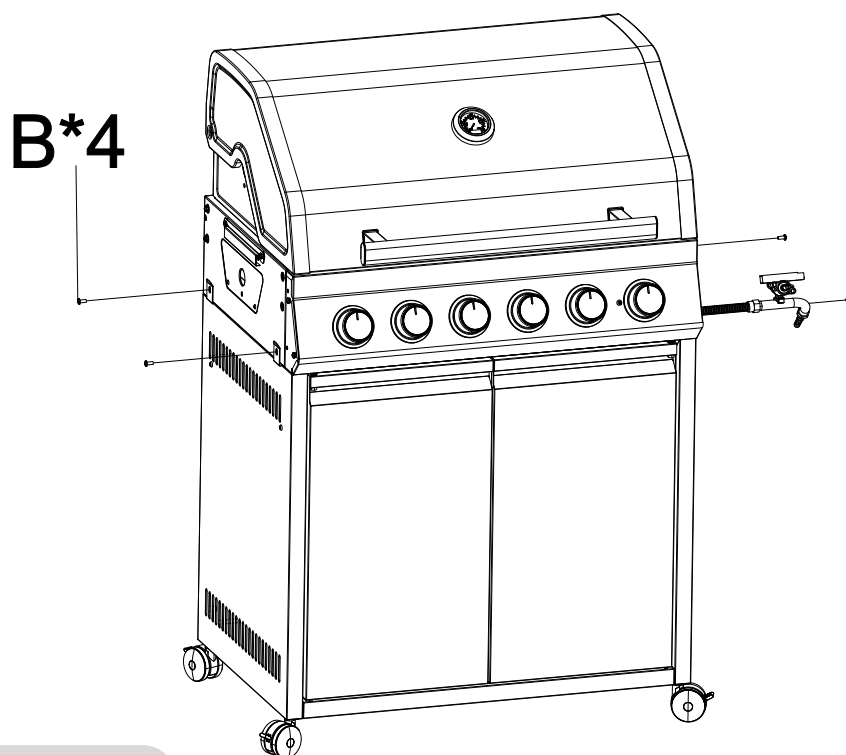

STEP 11

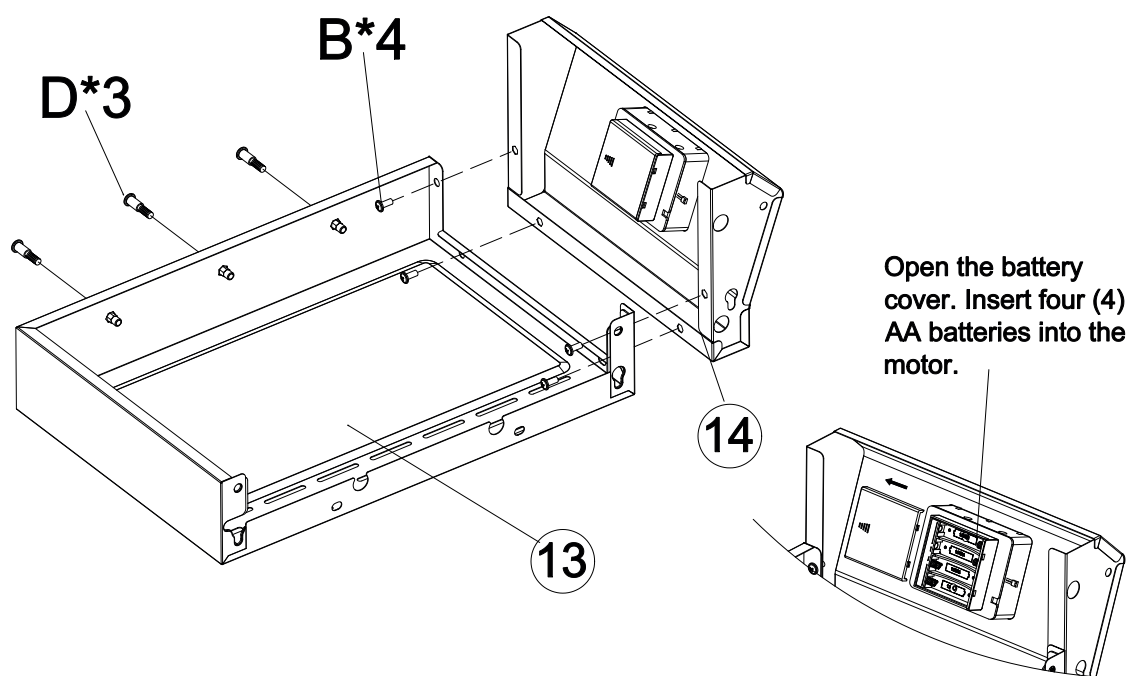

STEP 12

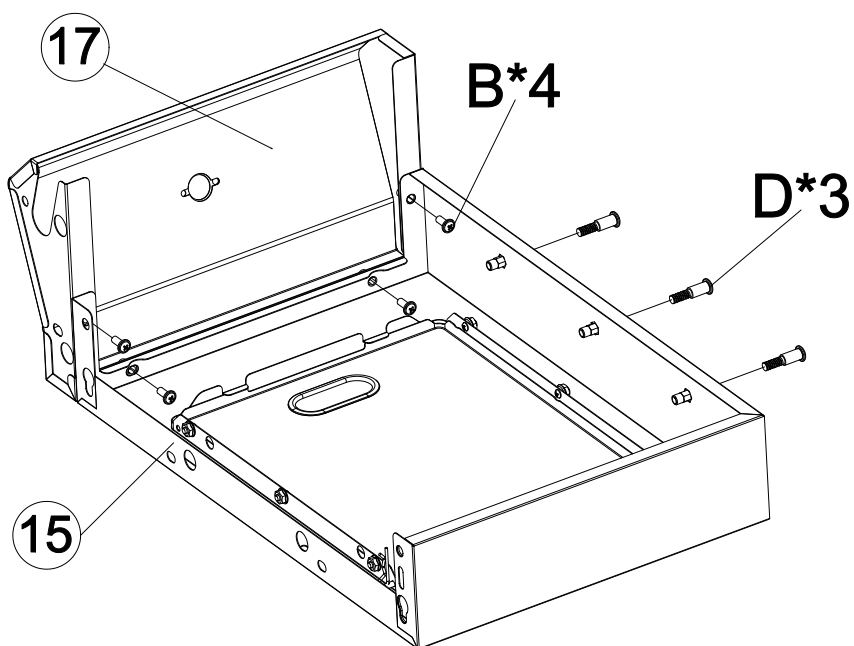

STEP 13

Ignition socket
(The wiring for the
furnace body temperature)

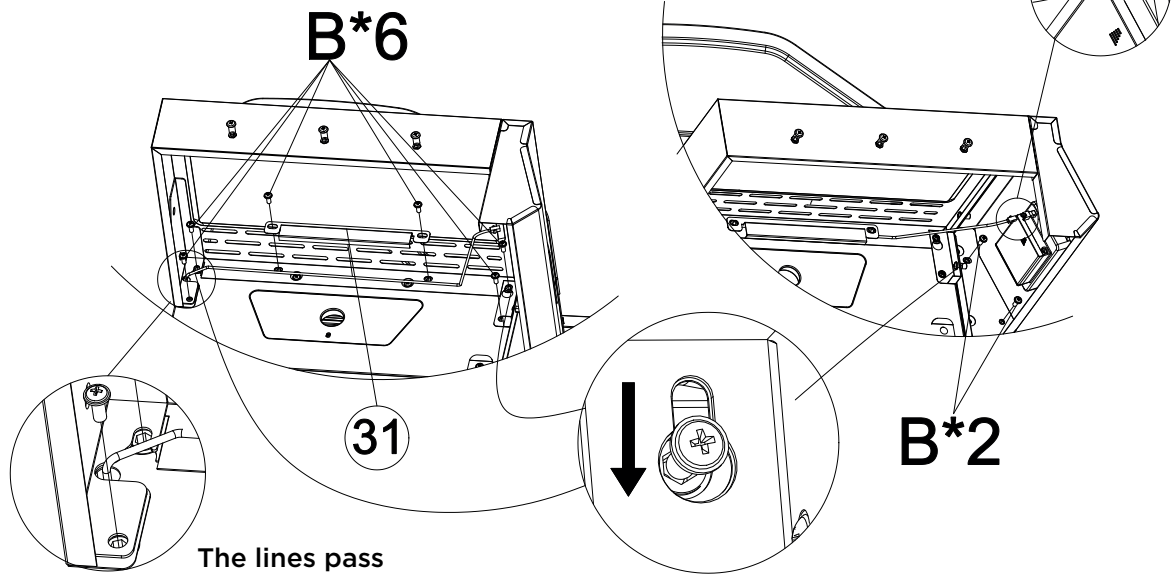

The lines pass
through the holes.

Turn the screws in halfway,
hang the parts and then
tighten fully to secure.



STEP 14

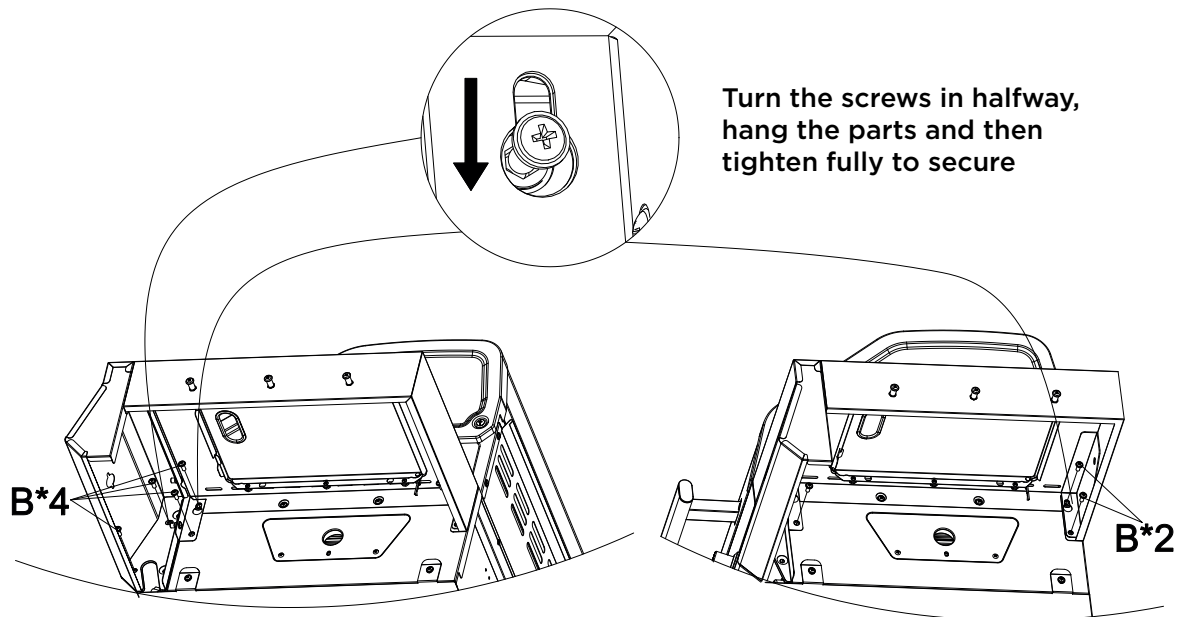

Turn the screws in halfway,
hang the parts and then
tighten fully to secure



STEP 15

Secure the side burner regulator to the front panel with two screws adding a knob base.

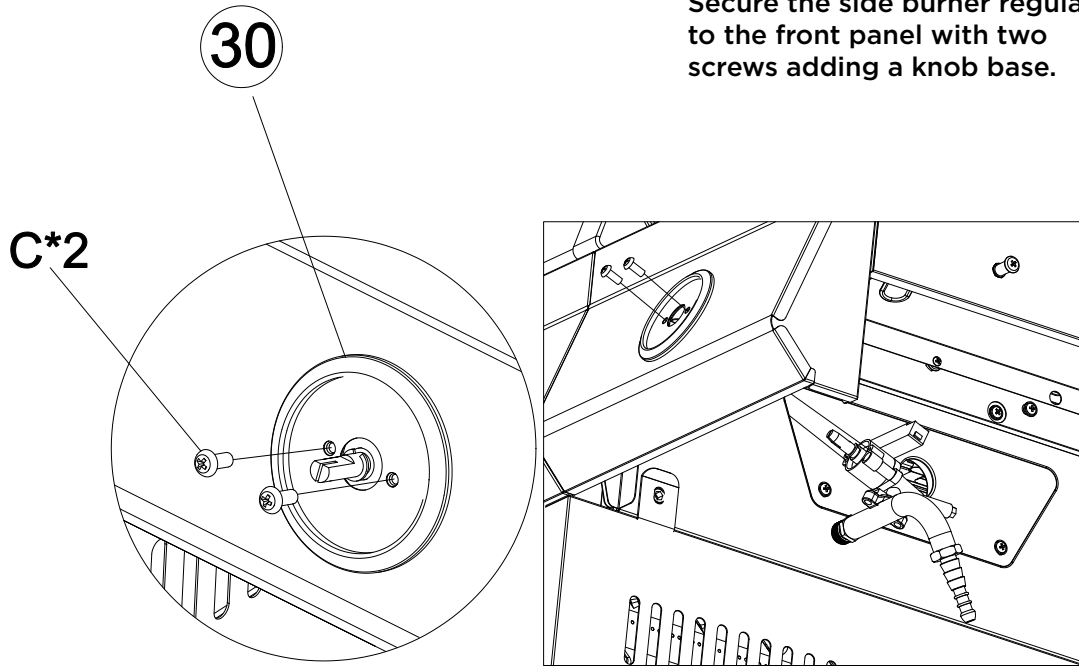

STEP 16

Step 1

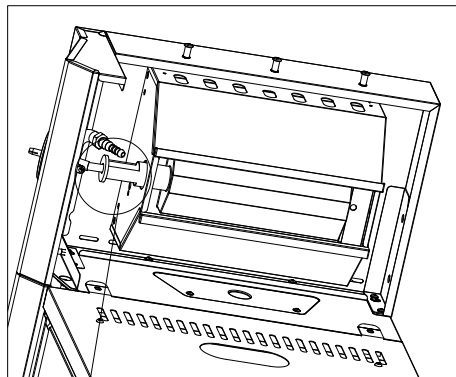

Push the side burner nozzle into the side burner pipe, but please note this is not a fully sealed part.

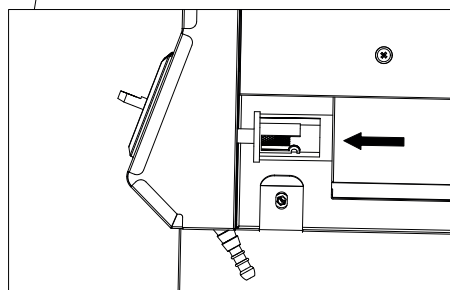

Step 2

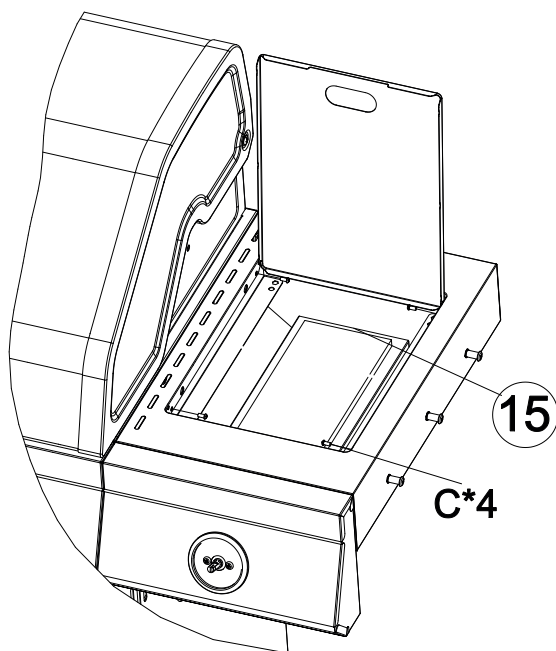

Step 3

Connect the side burner ignition wire.

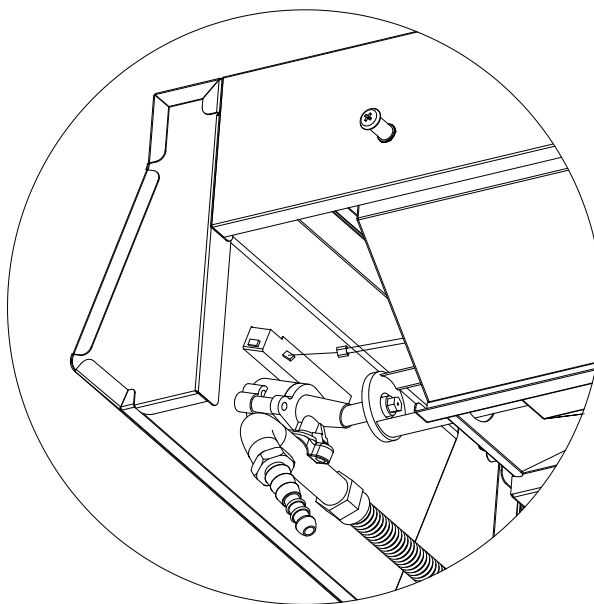

Step 4



STEP 17

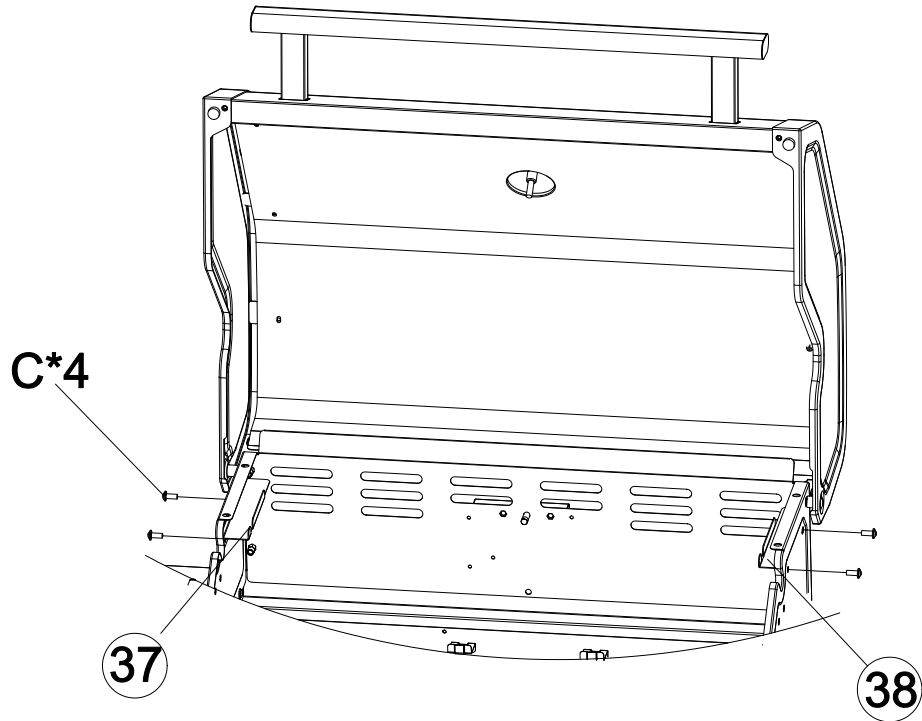

STEP 18

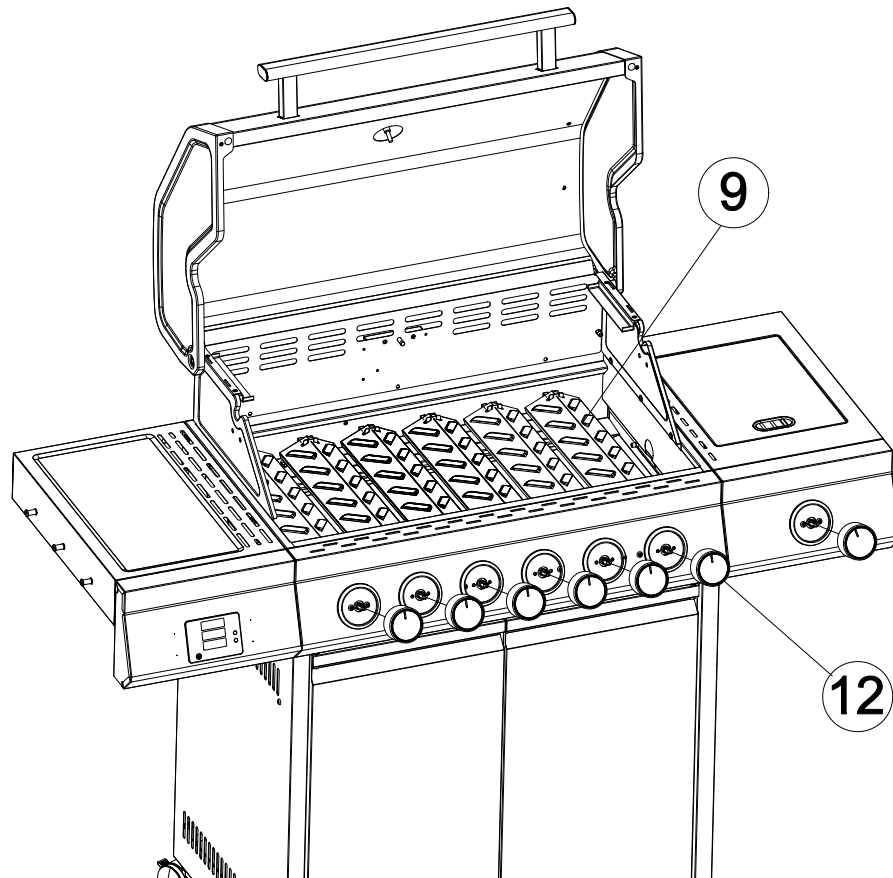

STEP 19

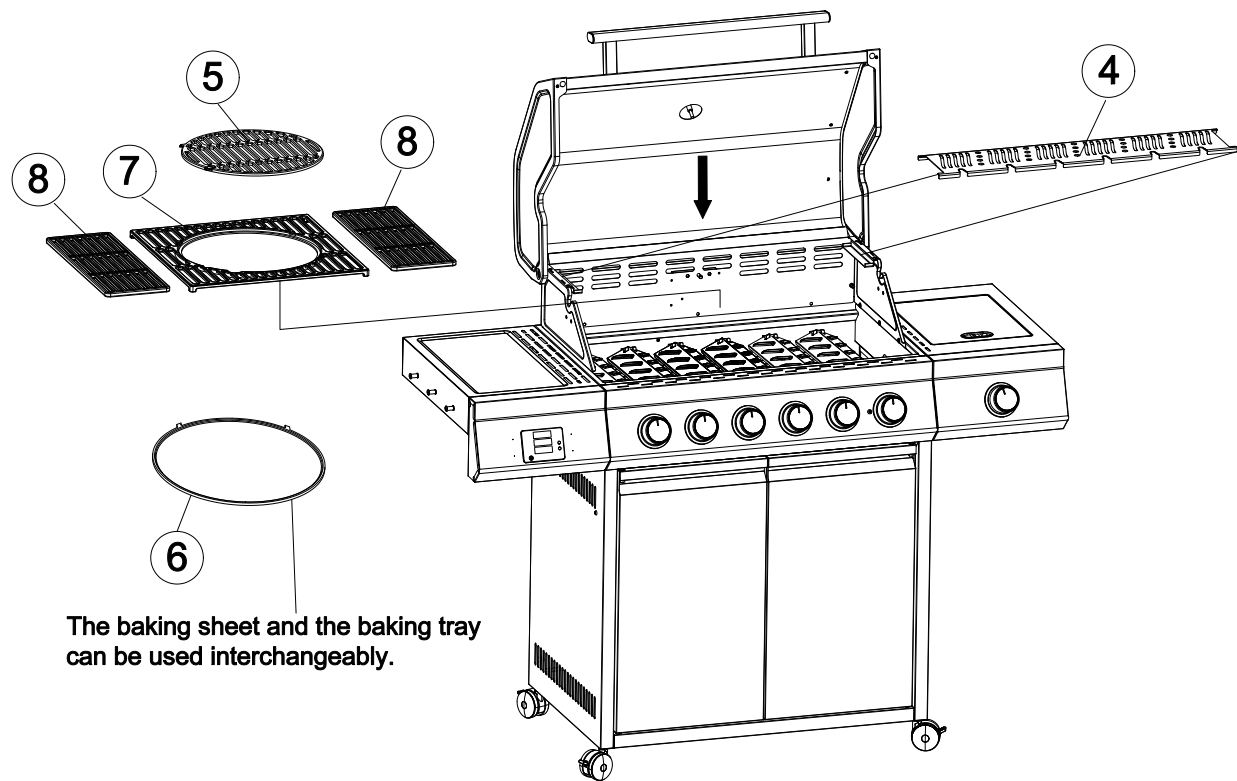

STEP 20

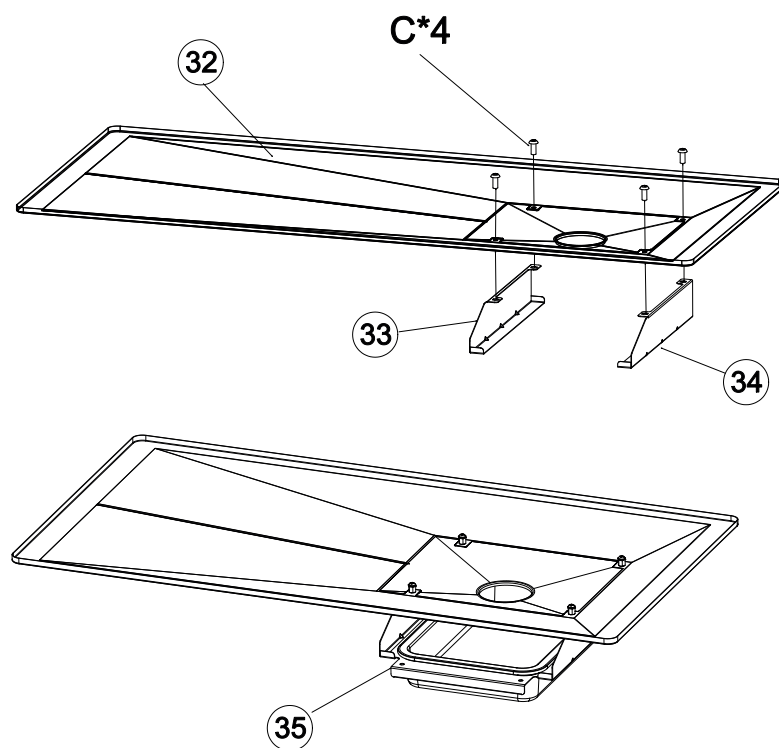

STEP 21

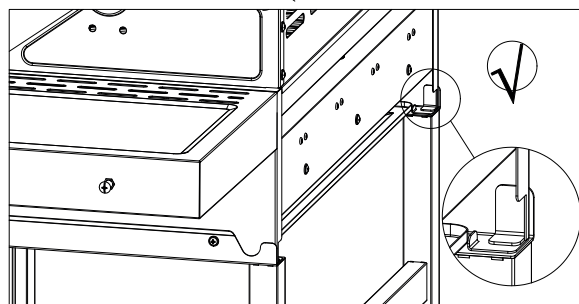
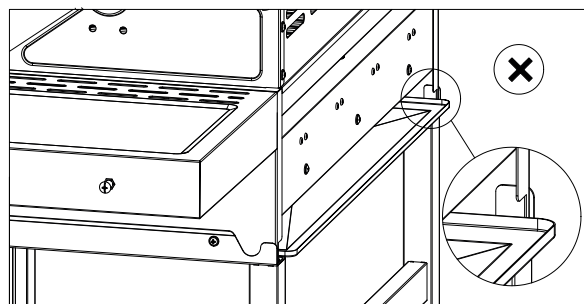
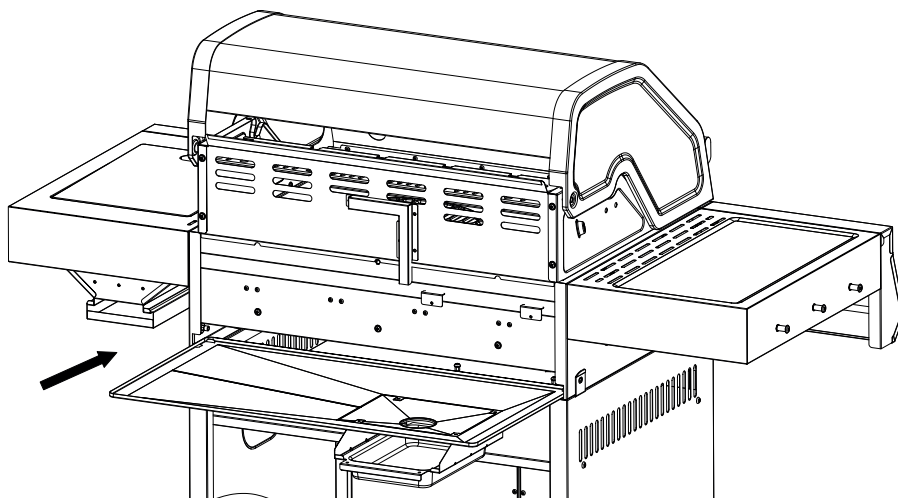

STEP 22

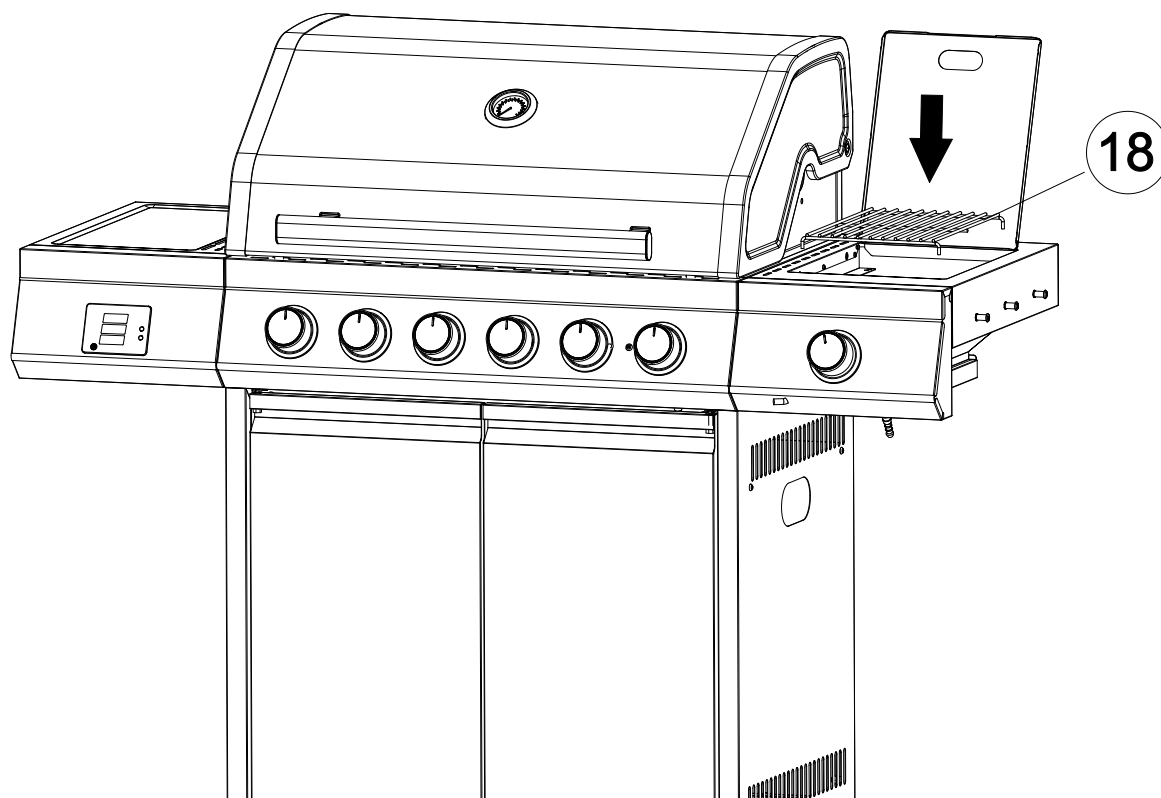

STEP 23

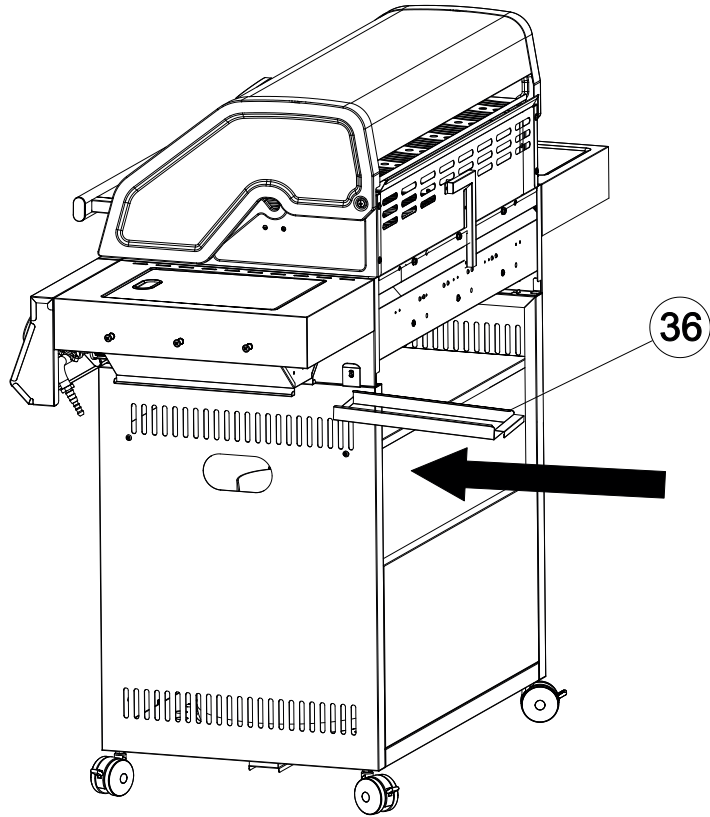

STEP 24

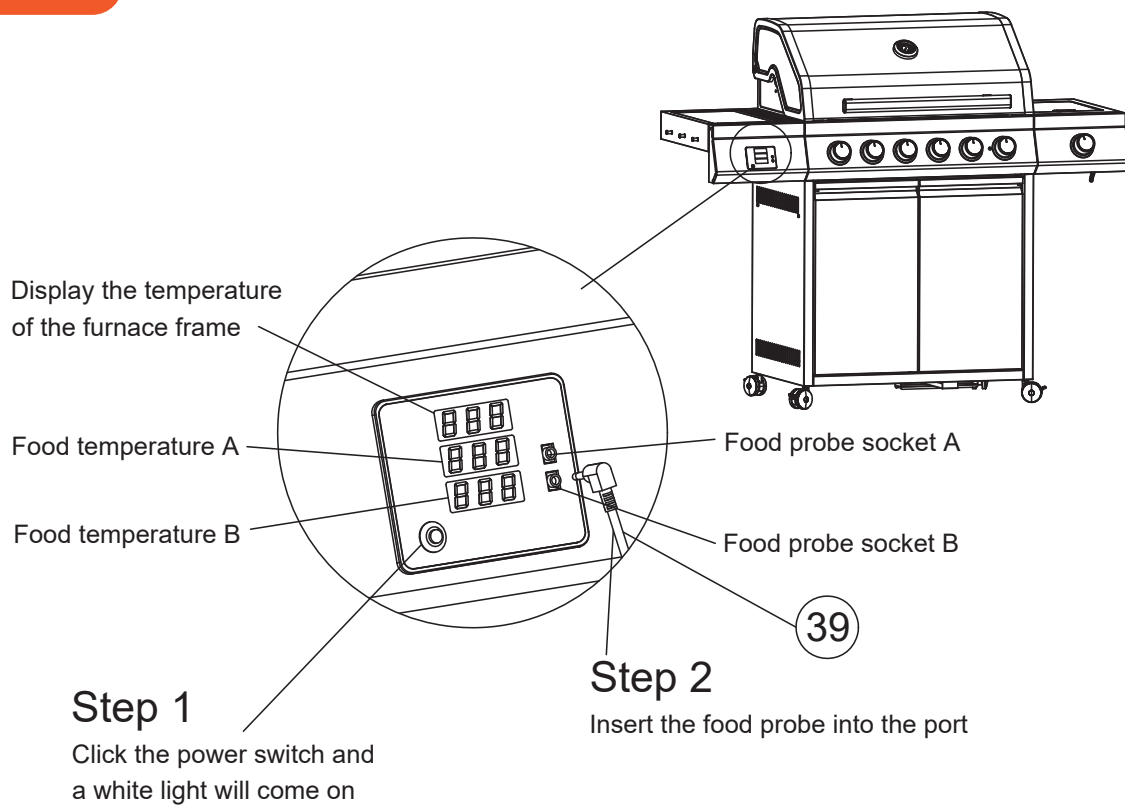

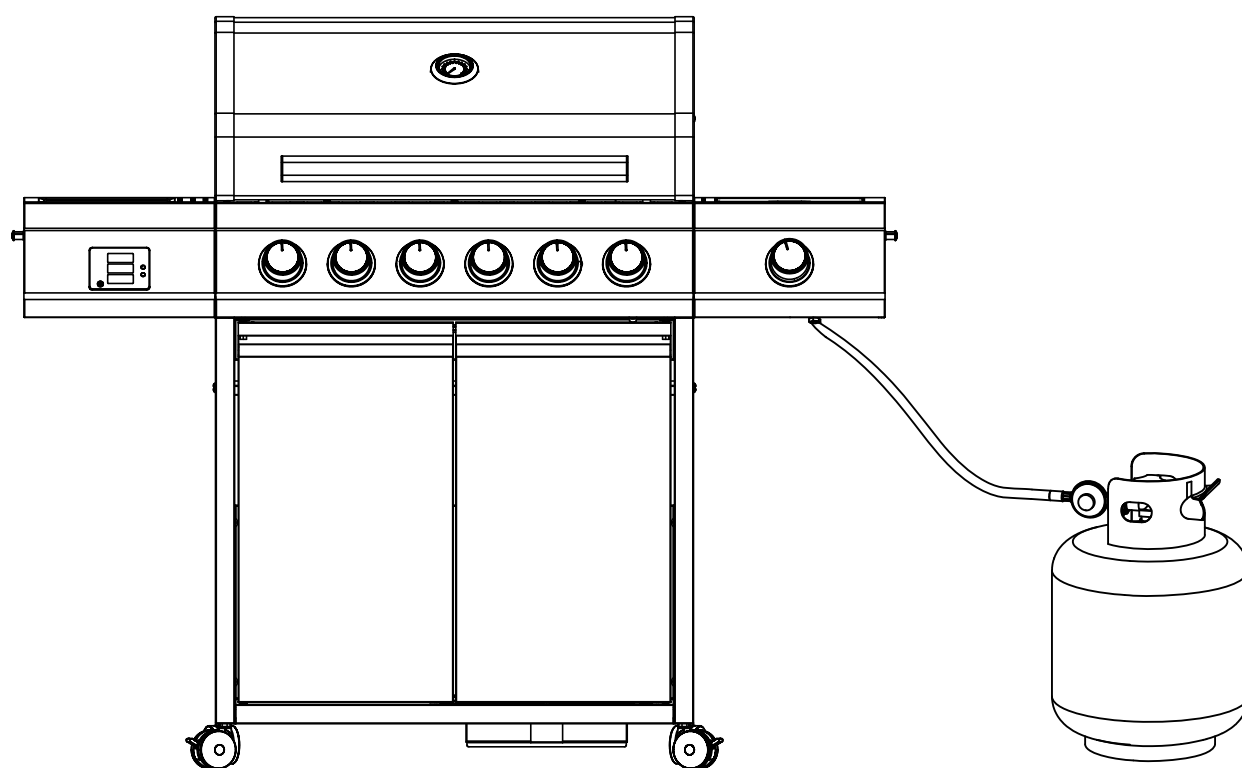

The gas bottle must be kept outside of the BBQ body when your BBQ is in use. Maximum gas bottle size should be 31cm(dia) × 45cm(H)



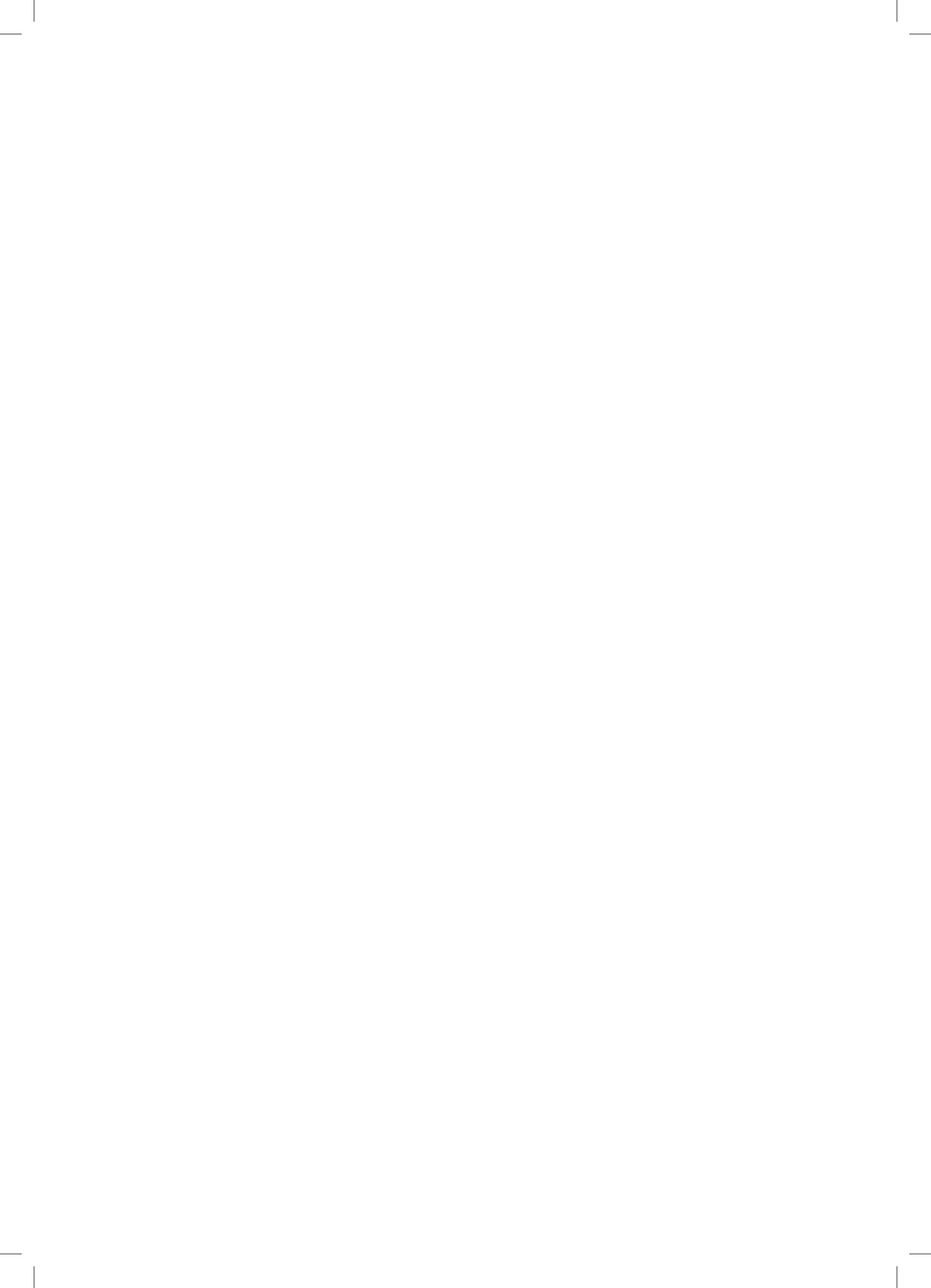

CHARLES
BENTLEY

EST. 1860



Treat your home to something special

Bring comfort, style and relaxation to your home. From elegant outdoor dining to beautiful lounge sets and casual everyday furniture - we help you create your dream indoor & outdoor space.

For inspirational, elegant, and stylish home and garden furniture ideas **visit [CharlesBentley.com](https://www.charlesbentley.com) today.**



ottimo

CharlesBentley.com
Charles Bentley & Son Limited, Loughborough, Leicestershire, LE11 5TP, UK
For EU Enquiries Contact: Authorised Rep Compliance Ltd., Ground Floor,
71 Lower Baggot Street, Dublin, D02 P593, Ireland. www.authorisedrepcompliance.com

excellent
**EVERY
TIME**